

MULTIPLE CHOICE FOR CSEC MATHEMATICS

Glen Dass

DO THIS BOOK IN ONE WEEK

1) Find the volume of the solid.

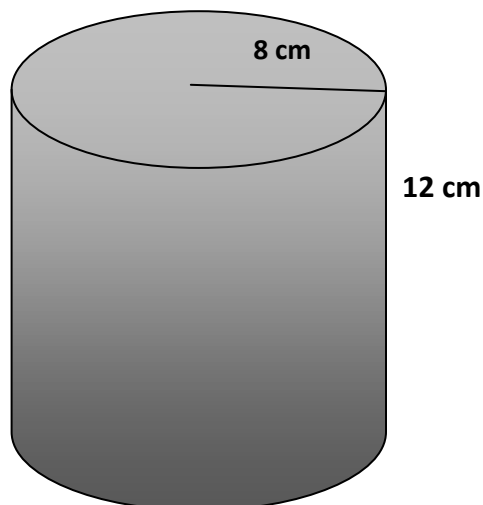

(A) 96π

(B) 192π

(C) 768π

(D) 768

<G|D|P>

MULTIPLE CHOICE FOR CSEC MATHEMATICS

Glen Dass

DO THIS BOOK IN ONE WEEK

1) Find the volume of the solid.

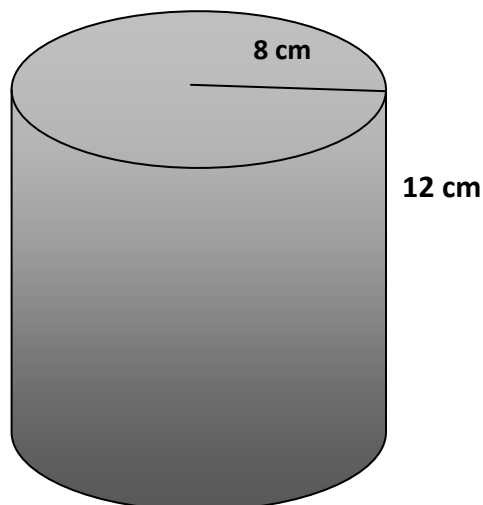

(A) 96π

(B) 192π

(C) 768π

(D) 768

<G|D|P>

PREFACE

The idea for this book came to me during the Covid-19 lockdown of 2020. In May of 2020, when CXC announced that most of the examinations for CSEC in July of that year would be paper 1 and SBA, I decided to work on a CSEC Mathematics Multiple Choice textbook. From past experience in setting multiple choice examinations for course work and end of term examinations, I had gathered the knowledge and I.T. skills needed to prepare my own multiple choice textbook.

I joined the Teaching Service in Trinidad and Tobago in 1995 as a Teacher of Mathematics and in 1997 I got a part time job teaching Mathematics to repeater students at a private Secondary School. At one point in time I was working part time at three private Secondary Schools while I was full time at a Government Secondary School. With repeater students, a lot of work needed to be done in a short space of time, from September to April the following year in order to ensure that they improved their grades. About three to five years of work had to be covered in this short space of time, so I designed my lesson plans and methods of teaching in such a way that I assumed they knew absolutely nothing in Mathematics. This meant that a tremendous amount of work had to be done on the board and adequate home work given regularly and corrected in order to make sure that students learnt something. I started from basic concepts in all of the CSEC Mathematics topics to make sure that most of the students understood the foundation work before proceeding to harder topics.

My lesson plans, assignments and methods of delivery helped me to be effective in the classroom and I was able to pitch the work for the mathematically weak students. Most repeater students often tell me that it was the first time that they actually understood certain topics. I have worked at public and private Secondary Schools in north, central and south Trinidad, so I got the opportunity to interact with students of all types of socioeconomic backgrounds with different levels of intelligence.

At the private Secondary Schools where I worked at in the past, I was able to teach a wide array of subjects which broadened my view, knowledge and experiences. I taught Additional Mathematics, Biology, Human and Social Biology, Physics, Integrated Science, Geography, Commercial Numeracy, SAT Mathematics, GMAT Mathematics, GRE Mathematics, Introductory Statistics for the Behavioural Sciences, Introduction to Statistics for Psychology, Introduction to Quantative Methods for the ABE program, Computer Literacy, PowerPoint Presentation, Microsoft Word and Graphics Design. In China, I taught Oral English, Conversational English, Business English and Tourism English. I also have the knowledge to teach Social Studies, History, Principles of Business, Economics, Sociology, Psychology, International Relations and Politics.

This book will help form four, form five and repeater students to develop skills, techniques and speed in answering multiple choice questions for the CSEC level. In the top Schools where students start form four work in form three, this book will benefit them.

I wish to dedicate this book and the others in the series to my **nephews and nieces Christon, Joel, Natalia, Faith and Paris (Popo).**

CONTENTS

1	Number theory and computation	4
2	Consumer arithmetic	20
3	Algebra	32
4	Sets	49
5	Measurement	67
6	Statistics	87
7	Relations functions and graphs	99
8	Geometry and trigonometry	139
9	Vectors and matrices	194
	ANSWERS	199

1 Number theory and computation

TEST 1

1) Five values are 7, 3, $3x$, 15 and 20. The mean is 12. Find x .

- (A) 6 (B) 5 (C) 4 (D) 3

2) $\left(\frac{3}{4}\right)^2 =$

- (A) $\frac{9}{16}$ (B) $\frac{6}{8}$ (C) $\frac{2}{3}$ (D) $\frac{6}{4}$

3) $5.1 \times 3.14 = 16.014$. Using this fact, find the value of 0.51×31.4

- (A) 16 (B) 160.14 (C) 16014 (D) 16.014

4) Write 5390.3 in standard form.

- (A) 5.3×10^3 (B) 5.390×10^2 (C) 5.3903×10^3 (D) 5.3903×10^2

5) Share \$1400 in the ratio 2 : 3 : 5.

- (A) \$280 : \$420 : \$700 (B) \$200 : \$400 : \$700
(C) \$300 : \$400 : \$600 (D) \$200 : \$300 : \$500

6) 50% of a number is 45. What is $\frac{2}{3}$ of this number?

- (A) 60 (B) 90 (C) 45 (D) 40

7) $2b$ is an even number. Which of the following is odd?

- (A) $2b + 2b$ (B) $2b + 2$ (C) $2b - 1$ (D) $2b - 2$

8) $86 \times 205 =$

(A) $(80 \times 200) + (6 \times 5)$

(B) $(86 \times 205) + (86 \times 205)$

(C) $(86 \times 200) + (86 \times 205)$

(D) $(86 \times 200) + (86 \times 5)$

9) What is the least number of mangoes that can be distributed among 4, 7 and 8 Teachers?

(A) 12

(B) 56

(C) 28

(D) 40

10) In the number 3.142, what is the value of the 2?

(A) $\frac{2}{1}$

(B) $\frac{2}{10}$

(C) $\frac{2}{100}$

(D) $\frac{2}{1000}$

11) In a Pure Mathematics class of 100 students, 70% are girls. 50% of the girls brought their laptops to class. How many girls brought their laptops?

(A) 30

(B) 40

(C) 35

(D) 70

12) $\frac{3}{4y} + \frac{5}{4y} =$

(A) $\frac{8}{4y}$

(B) $\frac{35}{4y}$

(C) $\frac{8}{8y}$

(D) $\frac{2}{4y}$

13) $a * b$ means $\sqrt{a^2 - b^2}$, find the value of $10 * 6$

(A) 6

(B) 2

(C) 64

(D) 8

14) 7, 4, 9, x and 13 give a mean of 7. Find x .

(A) 3

(B) 4

(C) 1

(D) 2

15) What percentage of 20 is 12?

(A) 60%

(B) 50%

(C) 40%

(D) 30%

16) $5.7 \times 0.23 = 1.311$, find the value of 0.57×2.3

- (A) 1311 (B) 13.11 (C) 1.311 (D) 131.1

17) $12.2 \div 0.02$

- (A) 600 (B) 601 (C) 550 (D) 610

18) Write 0.00987 in standard form.

- (A) 9.87×10^3 (B) 9.87×10^{-3} (C) 9.87×10^2 (D) 9.87×10^{-2}

19) Share \$800 in the ratio 3 : 5. How much is the smaller share?

- (A) \$500 (B) \$200 (C) \$300 (D) \$100

20) There are 50 students in an Engineering class. 60% of the class are boys. 40% of the boys wear contact lenses. How many boys wear contact lenses?

- (A) 30 (B) 20 (C) 25 (D) 12

TEST 2

1) $88 \times 120 =$

(A) $(88 \times 100) + (88 \times 20)$

(B) $(88 \times 120) + (88 \times 1)$

(C) $(80 \times 100) + (8 \times 20)$

(D) $(80 \times 120) + (8 \times 100)$

2) What is the value of the 5 in 31.253?

(A) $\frac{5}{1}$

(B) $\frac{5}{10}$

(C) $\frac{5}{100}$

(D) $\frac{5}{1000}$

3) $\sqrt{9} = 3$, what is $\sqrt{9 \times 10^2}$

(A) 300

(B) 3×1

(C) 3×10^2

(D) 3×10

4) Write 0.0421 in scientific notation.

(A) 4.21×10^2

(B) 4.21×10^{-2}

(C) 4.21×10^3

(D) 4.21×10^1

5) Find 12 as a percentage of 50.

(A) 20%

(B) 25%

(C) 24%

(D) 50%

6) Share \$1400 in the ratio 2 : 5. How much is the larger share?

(A) \$200

(B) \$400

(C) \$1000

(D) \$1200

7) $15.92 \times 2.02 =$. Write this answer to two significant figures.

(A) 32.2

(B) 32.16

(C) 33.0

(D) 32

8) Write 0.55 as a fraction in its lowest terms.

(A) $\frac{55}{100}$

(B) $\frac{11}{20}$

(C) $\frac{55}{1000}$

(D) $\frac{12}{20}$

9) $\frac{26.24 + 2.7}{1000} =$

- (A) 0.02994 (B) 0.02894 (C) 0.2994 (D) 2.894

10) $4.1 \times 2.5 + 0.9 \times 2.5 =$

- (A) 12.5 (B) 12.0 (C) 10.5 (D) 11

11) What is the value of the 4 in the number 3.1428?

- (A)
- $\frac{4}{10}$
- (B)
- $\frac{4}{20}$
- (C)
- $\frac{4}{1000}$
- (D)
- $\frac{4}{100}$

12) What is the largest prime number between 1 and 50?

- (A) 45 (B) 46 (C) 47 (D) 48

13) $3e$ is an even number. Which is odd?

- (A)
- $3e + 1$
- (B)
- $3e + 2$
- (C)
- $3e + e$
- (D)
- $3e - e$

14) $\frac{3}{4x} + \frac{4}{5x} =$

- (A)
- $\frac{7}{4x}$
- (B)
- $\frac{7}{20x}$
- (C)
- $\frac{30}{20x}$
- (D)
- $\frac{31}{20x}$

15) $x * y = 4x - y$, find $3 * 7$

- (A) 3 (B) 4 (C) 5 (D) 6

16) The mean of $2x + 3x + 4x + 5x$ is 10. Find the total of these four numbers.

- (A) 40 (B) 20 (C) 30 (D) 50

17) $(-3)^2 + (-7)^2 =$

- (A) 10 (B) 16 (C) -58 (D) 58

18) Wei and Lin shared a sum of money in the ratio 3 : 5. Wei got \$150. How much did Lin get?

- (A) \$200 (B) \$250 (C) \$300 (D) \$350

19) $12.06 \div 0.03 =$

- (A) 4.02 (B) 40.2 (C) 402 (D) 0.402

20) In a Physics test, Keith got 50% of a total of 110 marks. How much did he get?

- (A) 55 (b) 50 (C) 60 (D) 45

10) Share \$1200 in the ratio 5 : 7

- (A) \$700 : \$500 (B) \$200 : \$400 (C) \$400 : \$800 (D) \$500 : \$700

11) $35.1 \div 0.05 =$

- (A) 700 (B) 702 (C) 70 (D) 70.2

12) 80% of a number is 100. What is this number?

- (A) 100 (B) 150 (C) 125 (D) 200

13) $\frac{16.8 \div 1.2}{1000} =$

- (A) 0.0014 (B) 0.14 (C) 1.4 (D) 0.014

14) $-\left(\frac{2}{3}\right)^3 =$

- (A) $-\frac{8}{27}$ (B) $\frac{8}{27}$ (C) $\frac{4}{9}$ (D) $-\frac{4}{9}$

15) Find the HCF of 20, 25 and 40.

- (A) 3 (B) 4 (C) 5 (D) 10

16) $5m$ is an odd number. Which of the following is odd?

- (A) $5m - 1$ (B) $5m + 5m$ (C) $5m + 3m$ (D) $5m - 2$

17) Find the least number of cherries that can be shared equally among 8, 12 and 20 students.

- (A) 120 (B) 40 (C) 80 (D) 240

18) $4\frac{1}{2}\%$ of \$300 =

- (A) \$27 (B) \$13.50 (C) \$50 (D) \$600

$$19) \frac{2}{6x} + \frac{5}{6x} =$$

$$(A) \frac{7}{12x}$$

$$(B) \frac{3}{6x}$$

$$(C) \frac{7}{6x}$$

$$(D) \frac{3}{12x}$$

20) What percentage of 50 is 6?

(A) 10%

(B) 15%

(C) 20%

(D) 12%

TEST 4

1) Correct 3.142857 to 3 decimal places.

- (A) 3.143 (B) 3.1429 (C) 3.14 (D) 3.144

2) Write $5\frac{1}{8}$ as a decimal

- (A) 51.25 (B) 5.125 (C) 0.5125 (D) 512.5

3) A class has 60 students. 40% wear makeup. Out of this 40%, half were caught texting on their cellular phones. How many were caught texting?

- (A) 10 (B) 24 (C) 40 (D) 12

4) Share \$1100 in the ratios 2 : 4 : 5. Find the difference between the largest and the smallest.

- (A) \$500 (B) \$400 (C) \$300 (D) \$200

5) 50% of a number is 45. What is the number?

- (A) 45 (B) 100 (C) 90 (D) $22\frac{1}{2}$

6) $\left(-\frac{2}{5}\right)^3 =$

- (A) $-\frac{8}{125}$ (B) $\frac{8}{125}$ (C) $\frac{4}{25}$ (D) $-\frac{4}{25}$

7) Find the HCF of 12, 40 and 48.

- (A) 3 (B) 4 (C) 5 (D) 6

8) $6p$ is an odd number. Which of the following is odd?

- (A) $6p - 1$ (B) $6p + 1$ (C) $6p + 3$ (D) $6p$

9) $65 \times 15 + 65 \times 5 =$

- (A) 1300 (B) 1200 (C) 1600 (D) 6500

10) $\frac{8}{3x} - \frac{6}{3x} =$

- (A) $\frac{2}{6x}$ (B) $\frac{14}{3x}$ (C) $\frac{2}{3x}$ (D) $\frac{2}{4x}$

11) $x * y$ means $\sqrt{xy + y^2}$, find $3 * 8$

- (A) $\sqrt{80}$ (B) $\sqrt{88}$ (C) $\sqrt{32}$ (D) $\sqrt{27}$

12) 3.1428 correct to two decimal places

- (A) 3.143 (B) 3.1 (C) 3.1428 (D) 3.14

13) $(-5)^2 + (-6)^2 =$

- (A) 11 (B) -11 (C) 61 (D) -1

14) In scientific notation, 285.05 is

- (A) 2.8505×10^2 (B) 2.8505×10^{-2} (C) 2.8505×10^3 (D) 2.8505×10^{-3}

15) $0.854 \times 0.05 =$

- (A) 4270 (B) 0.427 (C) 0.0427 (D) 42.70

16) $4 - 1\frac{2}{3} =$

- (A) $3\frac{1}{3}$ (B) $2\frac{2}{3}$ (C) $3\frac{1}{3}$ (D) $2\frac{1}{3}$

17) $\frac{88.04 \div 0.02}{100} =$

- (A) 440.2 (B) 44.02 (C) 4.402 (D) 4402

18) Find the HCF of 20, 24 and 36

- (A) 3 (B) 4 (C) 5 (D) 6

19) $805 =$

- (A) $8 \times 10^2 + 5$ (B) $8 \times 10 + 5$ (C) $8 \times 10^1 + 5$ (D) 805×10^1

20) $38 \times 220 =$

- (A) $(38 \times 100) + (38 \times 20)$ (B) $(30 \times 200) + (8 \times 20)$
(C) $(38 \times 200) + (38 \times 20)$ (D) $(30 \times 100) + (8 \times 20)$

TEST 5

1) 8 out of 20. What percentage is this?

- (A) 20% (B) 16% (C) 25% (D) 40%

2) $8 \div 0.002 =$

- (A) 4000 (B) 400 (C) 40 (D) 4

3) $44 \times 10^n = 0.044$. What is the value of n ?

- (A) 3 (B) -3 (C) 2 (D) -2

4) 19.99×0.9 is approximately

- (A) 190 (B) 15 (C) 20 (D) 50

5) $(4 \times 6) + (4 \times 3)$ is the same as

- (A) 24 (B) 32 (C) 30 (D) 36

6) Find the HCF of 20, 60 and 100

- (A) 20 (B) 10 (C) 5 (D) 25

7) Find the least number of biscuits that can be shared equally among 5, 8 and 10 children.

- (A) 23 (B) 40 (C) 50 (D) 100

8) Given that $5a$ is an odd number, which is even?

- (A) $5a + 4$ (B) $5a - 2$ (C) $5a + 1$ (D) $5a + 2$

9) John bought $1\frac{9}{10}$ metres of cloth to make a pair of pants while Jane bought $1\frac{2}{3}$ metres of cloth to make her pair of pants. How much more cloth did John bought?

- (A) $\frac{5}{30}$ m (B) $\frac{7}{10}$ m (C) $\frac{2}{3}$ m (D) $\frac{7}{30}$ m

10) $1\frac{9}{10}$ % of \$700 =

- (A) \$1330 (B) \$13.3 (C) \$133 (D) \$1.33

11) $(-4)^2 + (-3)^2 =$

- (A) 25 (B) -7 (C) 13 (D) -1

12) Two students share \$100 in the ratio 2 : 3. How much do they get?

- (A) \$60 : \$40 (B) \$20 : \$30 (C) \$40 : \$60 (D) \$40 : \$50

13) $275 \times 120 =$

- (A) 32000 (B) 30000 (C) 27500 (D) 33000

14) A student got 70% in a Mathematics examination. The total score of the examination was 120 marks. What was the student's score?

- (A) 84 (B) 85 (C) 75 (D) 70

15) 20% of a number is 15. What is this number?

- (A) 50 (B) 100 (C) 75 (D) 30

16) What is the value of the 3 in the number 87.314

- (A) $\frac{3}{1}$ (B) $\frac{3}{10}$ (C) $\frac{3}{100}$ (D) $\frac{3}{1000}$

17) Find the HCF of 15, 20 and 45.

- (A) 15 (B) 10 (C) 3 (D) 5

18) What is the next term in the sequence 1, 3, 6, 10, 15

- (A) 21 (B) 20 (C) 19 (D) 18

19) $27 \times 14 + 27 \div 3 =$

- (A) 135 (B) 405 (C) 387 (D) 378

20) $x * y$ means $\frac{x}{y} - 2$, find the value of $10 * 2$

- (A) 5 (B) 3 (C) 4 (D) 6

Glen Dass Publishing

Trinidad and Tobago

Cellular phone contact: 1-868-473-5600.

Email address: glendasspublishing@hotmail.com



<G|D|P>

- 1.GET THESE BOOKS ON AMAZON.**
- 2.PDF COPIES ARE AVAILABLE FOR THE PUBLIC TO PURCHASE. SEND AND E-MAIL TO FIND OUT HOW TO ORDER.**
- 3.MORE BOOKS WILL BE ADDED TO THE LIST LATER THIS YEAR.**

1. Multiple Choice for CSEC Mathematics by Glen Dass.
2. Construction for CSEC Mathematics by Glen Dass.
3. Bearings for CSEC Mathematics by Glen Dass.
4. SBA Model Answers for CSEC Mathematics by Glen Dass.
5. Transformations Workbook for CSEC Mathematics by Glen Dass.
6. Office Administration Workbook for CSEC by Glen Dass.
7. One Sample SBA for CSEC History and One Sample SBA for CSEC Geography by Glen Dass.
8. Inventing: a simple guide for beginners by Glen K. Dash.

2 Consumer arithmetic

TEST 1

1) US\$1.00 = EC\$2.50. Convert US\$150 to EC\$.

- (A) \$300 (B) \$250 (C) \$350 (D) \$375

2) Mr. Tang changes US\$600 to TT\$ at the bank where the rate of exchange is TT\$6.80 = US\$1. He pays a service charge of TT\$35.00. How much does he receive?

- (A) TT\$4045 (B) TTS4000 (C) TTS4080 (D) TT\$3900

3) A woman receives \$1600 a week in salary. She works 11 hours overtime at which she receives \$50 per hour. What is her total salary for the week?

- (A) \$2100 (B) \$2200 (C) \$2150 (D) \$2000

4) $P = \$800$, $R = 6\%$, $T = 5$ years. Find the simple interest.

- (A) \$200 (B) \$240 (C) \$250 (D) \$175

5) A sales tax of 15% is charged on all items at Eddy's Store. A customer buys a school bag that is marked at \$200. What is the total bill?

- (A) \$30 (B) \$215 (C) \$205 (D) \$230

6) A 20% discount is given at an Easter sale. A customer's bill is \$700. What is her payment after she gets the discount?

- (A) \$720 (B) \$820 (C) \$560 (D) \$500

7) The value of a car is \$90,000. A salesman gets a commission of 7% on every vehicle he sells. How much commission does he get when he sells this particular car?

- (A) \$6300 (B) \$5000 (C) \$6000 (D) \$96,000

8) An electric vehicle worth \$100,000 depreciates at a rate of 25% each year. What is the value of the car at the end of two years?

- (A) \$75000 (B) \$56250 (C) \$56000 (D) \$50000

9) A microwave oven is priced at \$300. A discount of 20% is given. How much is the discount?

- (A) \$320 (B) \$20 (C) \$330 (D) \$60

10) A car depreciates at a rate of 15% per annum. In January its value is \$80,000. What is its value at the end of December in that year?

- (A) \$68000 (B) \$15000 (C) \$60000 (D) \$55000

11) Chin bought a laptop for \$2000 and sells it to his neighbor for \$2700. What is his percentage profit?

- (A) 700% (B) 70% (C) 35% (D) 135%

12) Betty's annual salary is \$96,000. Her tax free allowance is \$32,000. Her tax rate is 30%. How much tax she has to pay?

- (A) \$64000 (B) \$20000 (C) \$32000 (D) \$19200

13) A loan of \$10,000 was taken from a bank and its simple interest was \$1200. The amount of time to repay the loan was 4 years. Find the rate of interest.

- (A) 3% (B) 4% (C) 5% (D) 6%

14) The price of a computer is \$5000. It can be bought on hire purchase with a down payment of \$2000 and 12 monthly installments of \$300 each. How much extra is paid with the hire purchase plan?

- (A) \$500 (B) \$3600 (C) \$600 (D) \$300

15) An item is marked at \$80 and a sales tax of 7% is charged. How much does a customer pay for the item?

- (A) \$85.00 (B) \$87.00 (C) \$73.00 (D) \$85.60

16) Rohan bought a cellular phone that is marked at \$1400 plus tax. This tax is charged at 12%. How much change will he receive when he pays with \$1600?

- (A) \$32 (B) \$35 (C) \$30 (D) \$12

17) An SUV depreciates by 20% each year. By December it was worth \$80,000. What was its value at the beginning of the year?

- (A) \$60,000 (B) \$110,000 (C) \$100,000 (D) \$60,000

18) A power bank was bought for \$300 and sold for \$350. Find the percentage profit.

- (A) 15% (B) 16.7% (C) 50% (D) 20%

19) A recliner is priced at \$1500. On hire purchase, a deposit of \$700 is made and 12 monthly installments of \$100 each have to be paid after. How much is saved if the recliner was paid for in cash.

- (A) \$500 (B) \$200 (C) \$700 (D) \$400

20) A supermarket has 4 cashiers who work at a rate of \$80 per day and 16 other workers and they get \$70 per day. Find the daily wage bill.

- (A) \$1440 (B) \$1400 (C) \$1500 (D) \$1300

TEST 2

1) Find the rate if a loan of \$20000 earned an interest of \$3000 and the person has 5 years to repay the loan plus the interest.

- (A) 3% (B) 4% (C) 5% (D) 6%

2) A student bought a geometry set for \$20 and sold it to make a 25% profit. How much extra did she make?

- (A) \$6 (B) \$25 (C) \$5 (D) \$4

3) Sue bought a calculator for \$80 and sold it to make a 20% profit. Find the profit.

- (A) \$20 (B) \$16 (C) \$96 (D) \$25

4) A 70 inches flat screen television costs \$5000. It can be purchased on hire purchase with a down payment of \$2000 and 12 monthly installments of \$300 each. How much can be saved if the television was bought in cash?

- (A) \$5600 (B) \$500 (C) \$3600 (D) \$600

5) Dinner at Marlene's restaurant is \$150 plus 20% tax. What is the total bill?

- (A) \$170 (B) \$130 (C) \$180 (D) \$140

6) During a Christmas sale a 12% discount is given. A toy is priced at \$200. What price do I pay?

- (A) \$176 (B) \$212 (C) \$224 (D) \$180

7) Find the rate if the interest on \$1000 for 4 years is \$100.

- (A) 3% (B) 2.5% (C) 5% (D) 4%

8) Smith's annual salary is \$200,000. His taxable allowance is \$30,000. His rate of tax is 30%. Calculate his tax.

- (A) \$30000 (B) \$170000 (C) \$51000 (D) \$60000

9) TT\$6.60 = US\$1. How many US\$ are there in TT\$330.

- (A) US\$40 (B) US\$30 (C) US\$60 (D) US\$50

10) The advertised price of a stove is \$2500. A discount of 10% is given. How much does Tom pay for the stove?

- (A) \$2300 (B) \$2250 (C) \$2400 (D) \$2350

11) Lin buys a table for \$300 and sells it to make a 12% profit. What is her profit?

- (A) \$36 (B) \$13 (C) \$312 (D) \$264

12) The sales tax on a leather bag is 18%. If the bag is marked \$120, find the total bill.

- (A) \$141.60 (B) \$140 (C) \$138 (D) \$102

13) A dining table is priced at \$2400. A deposit of \$500 is made with a 12 monthly installments of \$200 each. How much is saved if the table is bought in cash?

- (A) \$2400 (B) \$2900 (C) \$500 (D) \$600

14) The interest on a sum of money invested at 10% per annum for 5 years is \$500. How much was invested?

- (A) \$500 (B) \$600 (C) \$800 (D) \$1000

15) Cupido paid \$80 for a handbag. She got a \$20 discount. What was the percentage discount quoted on the handbag?

- (A) 10% (B) 20% (C) 25% (D) 40%

16) Find the rate of interest if \$2000 was invested for 4 years and it gained an interest of \$400.

- (A) 5% (B) 4% (C) 3% (D) 6%

17) Xi's taxable income is \$85,400. His rate of tax is 25%. How much does he pay in tax?

- (A) \$21000 (B) \$20000 (C) \$25000 (D) \$21350

18) A property is valued at \$400,000. Property Tax is charged at \$0.20 per \$100 value. Find the amount this owner has to pay.

- (A) \$8000 (B) \$800 (C) \$80000 (D) \$800000

19)

Value of land: \$500,000
Value of house: \$800,000
Rates of tax:
On house: 12 cents per \$100
On land: 17 cents per \$100

Calculate the total property tax this person has to pay at the end of the year.

- (A) \$1800 (B) \$960 (C) \$1810 (D) \$850

20) The value of a plot of land is \$480,000. Land tax is at a rate of 35 cents per \$100. How much tax has to be paid on this lot of land?

- (A) \$16800 (B) \$168000 (C) \$240000 (D) \$1680

TEST 3

1) In January a utility truck is valued at \$45,000. The rate of depreciation is 8% per year. What is the value of the truck at the end of the year?

- (A) \$41400 (B) \$48600 (C) \$40000 (D) \$41000

2) The price of a Samsung Galaxy is \$2500. Chelsey Munroe bought it and sold it for \$3000. Find her percentage profit.

- (A) 25% (B) 500% (C) 20% (D) 15%

3) Carolyn buys a scientific calculator that is advertised for \$150. She has to pay a sales tax of 15%. She pays with \$200. How much change does she receive?

- (A) \$22.50 (B) \$27.50 (C) \$50.00 (D) \$20.00

4) Find the rate on a loan of \$10,000 that was taken for 3 years and accrued an interest of \$1200.

- (A) 8% (B) 3% (C) 5% (D) 4%

5) The price of a pair of sneakers is \$250. A 10% discount is given. How much does Neil Paul pay?

- (A) \$240 (B) \$260 (C) \$220 (D) \$225

6) Find the simple interest on \$20,000 at a rate of 12% for 4 years.

- (A) \$9600 (B) \$960 (C) \$900 (D) \$1000

7) At a Boxing Day sale, a discount of 20% is given on all items. A refrigerator is marked at \$3300. How much does Neil and Anjane pay?

- (A) \$2600 (B) \$3960 (C) \$2640 (D) \$3000

8) Rian bought a surge protector for \$150 and sold it for \$200. Find his percentage gain.

- (A) 30% (B) 50% (C) 20% (D) 33.3%

9) At the bakery, a cake is priced at \$70 plus 7% sales tax. Find the final price.

- (A) \$74.90 (B) \$77 (C) \$74 (D) \$63

10) The rate of depreciation of an electric vehicle is 5% per annum. The price of a Tesla is US\$45,000. What is its value at the end of the year?

- (A) \$50000 (B) \$40000 (C) \$42750 (D) \$42000

11) The simple interest on \$1200 for 3 years is \$60. Find the rate of interest.

- (A) $1\frac{1}{3}\%$ (B) $1\frac{2}{3}\%$ (C) $1\frac{3}{4}\%$ (D) 3%

12)

Cost of gas: 70 cents for 300 m³

Fixed charge: \$11.50

A Port of Spain taxi driver buys 60,000 m³ of gas. Calculate his bill.

- (A) \$140 (B) \$200 (C) \$150 (D) \$151.50

13) Find the simple interest on \$16,000 at a rate of 11% for 5 years.

- (A) \$8800 (B) \$8000 (C) \$800 (D) \$80000

14) A building is valued at \$450,000. Property tax is charged at \$0.35 cents per \$100. Calculate the amount of property tax on this building.

- (A) \$1500 (B) \$157500 (C) \$1575 (D) \$35000

15) A 12% discount is given on a laptop case that is marked at \$2000. Find the discount.

- (A) \$200 (B) \$240 (C) \$1760 (D) \$2240

TEST 4

1) At Christian Toppin's restaurant, the wages are as follows:

20 counter attendants and cooks at \$120 per day.

10 general workers at \$90 per day.

Find the total daily wage bill.

- (A) \$3500 (B) \$4000 (C) \$3300 (D) \$3000

2) TT\$6.60 = US\$1. How many US\$ in TT\$330?

- (A) US\$50 (B) US\$2175 (C) US\$60 (D) US\$55

3) A saleslady gets an 11% commission on her total sales. Last month her total sales were \$110,000. What was her commission?

- (A) \$12000 (B) \$12000 (C) \$11000 (D) \$12100

4) The marked price for a multiple choice Mathematics textbook is \$150. A sales tax of 8% is charged. How much does a CSEC student pay for this book?

- (A) \$138 (B) \$162 (C) \$158 (D) \$150

5) Radica's mom bought a wardrobe on hire purchase with a deposit of \$600 and 18 monthly payments of \$110 each. Calculate the total amount she pays.

- (A) \$710 (B) \$1920 (C) \$2580 (D) \$2500

6) A loan of \$10,000 was repaid in 3 years with monthly installments of \$400. What was the interest rate?

- (A) $14\frac{2}{3}\%$ (B) $11\frac{2}{3}\%$ (C) $10\frac{3}{4}\%$ (D) 3%

15) Basant bought a laptop for \$3000 and sold it to Cassie at a price of \$4000. How much did he gain?

- (A) \$1000 (B) \$7000 (C) \$4000 (D) \$1500

16) Raquel bought a tablet for \$800 and sold it to Toppin for \$1200. What is her percentage profit?

- (A) 45% (B) 50% (C) 66.7% (D) 150%

17) A printing press depreciates at a rate of 8% per annum. Its current value is \$250,000. What will be its value at the end of two years?

- (A) \$230,000 (B) \$270,000 (C) \$200,000 (D) \$211,600

18) At Paul's furniture store, salespersons are paid a commission of 5% on their total sales per month. Last month Priya made a total sale of \$90,000. How much is her commission?

- (A) \$5000 (B) \$4000 (C) \$4500 (D) \$3500

19) Mr. Sammy gives 5% discount for Chemistry lessons when students pay the full yearly tuition fee before the end of September. Christopher paid his full fee of \$2800 before the end of September. How much discount does he get?

- (A) \$140 (B) \$150 (C) \$2940 (D) \$160

20) At Ram and Sons Furniture Factory, clerical workers are paid \$180 per day and general workers are paid \$150 per day. There are 12 clerical workers 55 general workers. Calculate the total wage bill for last week if all the workers worked from Monday to Saturday.

- (A) \$62,000 (B) \$62,460 (C) \$82,500 (D) \$100,000

3 Algebra

TEST 1

1) Simplify $12a + 8b - 3(4a - 5b) =$

- (A) $23b$ (B) $24a + 23b$ (C) $20a + 20b$ (D) $25b$

2) $-(5m) - (2m) =$

- (A) $3m$ (B) $7m$ (C) $-7m^2$ (D) $-7m$

3) $a^7 \div a^4 =$

- (A) a^{11} (B) a^3 (C) a^7 (D) a^4

4) $\frac{x}{4} = 16$ Find x

- (A) 4 (B) 20 (C) 64 (D) 12

5) 10 is added to 4 times a number y . Which expression represents this statement?

- (A) $10 + y$ (B) $10 + 4$ (C) $10(4 + y)$ (D) $10 + 4y$

6) If $a = 3$ and $b = 5$, find the value of $\frac{4a + b^2}{ab}$

- (A) $\frac{37}{15}$ (B) $\frac{8}{15}$ (C) $\frac{17}{15}$ (D) $\frac{29}{15}$

7) Find x given that $4(x - 2) - 3(x + 5) = 10$

- (A) 23 (B) 33 (C) -13 (D) 13

8) $2\frac{1}{2} + x = 5\frac{3}{4}$ What is the value of x ?

- (A) $8\frac{1}{4}$ (B) $2\frac{1}{4}$ (C) $3\frac{1}{4}$ (D) $3\frac{3}{4}$

9) Solve: $6 < 3x \leq 12$

- (A) $2 \leq x \leq 4$ (B) $2 < x < 4$ (C) $2 \leq x < 4$ (D) $2 < x \leq 4$

10) Expand $(x + 5)(x - 2)$ and state the coefficient of x .

- (A) 1 (B) 3 (C) -10 (D) $3x^2$

11) Nine times the product of two numbers can be written as

- (A) $9ab$ (B) $9 + ab$ (C) $9 + a + b$ (D) ab

12) $4a^4 \times 2a^2 =$

- (A) $8a^2$ (B) $8a^4$ (C) $8a^6$ (D) $4a^2$

13) If $x = -3$, find the value of $\frac{x^3}{-6 + x}$

- (A) -3 (B) 1 (C) -1 (D) 3

14) Find x when $8(3x - 2) = 56$

- (A) -3 (B) 1 (C) -1 (D) 3

15) Ann has y apples and gives away 7. How many she now has?

- (A) $y - 7$ (B) $y + 7$ (C) $7y$ (D) $y \div 7$

16) Find x when $3(x - 8) = 21$

- (A) 1 (B) 15 (C) 3 (D) 24

17) Solve: $4 < 2x \leq 16$

- (A) $x \leq 6$ (B) $2 \leq x \leq 8$ (C) $2 < x \leq 8$ (D) $x \leq 20$

18) Find the value of $\frac{a^2 + 4b}{ab}$ when $a = 7$ and $b = 10$

- (A) $\frac{89}{70}$ (B) $\frac{49}{70}$ (C) $\frac{40}{70}$ (D) $\frac{17}{70}$

19) Expand $-5(y - 3)$

- (A) $5y + 15$ (B) $-5y - 15$ (C) $5y - 15$ (D) $-5y + 15$

20) $(6y)^2 =$

- (A) $6y^2$ (B) $36y^2$ (C) $36y$ (D) $12y^2$

TEST 2

1) $5(x - 2) - 3(x - 2) = 20$

What is the value of $(x - 2)$?

(A) 18

(B) 17

(C) 10

(D) 28

2) $3^8 \div 3^6 =$

(A) 3^2

(B) 3^{14}

(C) 9^2

(D) 9^{14}

3) $(2x + 3)(3x - 2) =$

(A) $6x^2 - 5x - 6$

(B) $6x^2 + 5x + 6$

(C) $x^2 + 5x - 6$

(D) $6x^2 + 5x - 6$

4) Simplify $\frac{x^8 \times x^3}{x^6}$

(A) x^2

(B) x^5

(C) x^{17}

(D) x^4

5) $\frac{y}{4} = 35$ Find y

(A) 8.75

(B) 8.25

(C) 150

(D) 140

6) x multiplied by its reciprocal is

(A) $x \times \frac{1}{x}$

(B) $x \times \frac{x}{1}$

(C) $x \times \frac{x}{x}$

(D) $x \times \frac{1}{2x}$

7) $7 - \frac{9}{x} = 4$

Find x

(A) 27

(B) 2

(C) 3

(D) 20

8) When $x = 2$, $y = 3$ and $z = 6$, find the value of $7xy - 3z$

- (A) 18 (B) 24 (C) 60 (D) 27

9) Solve: $3(x - 4) - 5(x + 5) = 0$

- (A) 18.5 (B) -37 (C) 37 (D) -18.5

10) **Two numbers give 27 when added and 3 when subtracted.** Which pair of simultaneous equations represent this statement?

- (A) $x + y = 27$ and $x - y = 3$ (B) $xy = 27$ and $x \div y = 27$
(C) $x + y = 3$ and $x - y = 27$ (D) $x - y = 27$ and $x + y = 3$

11) $4x^2 \times 3x^7 =$

- (A) $7x^9$ (B) $12x^2$ (C) $12x^9$ (D) $12x^7$

12) $(a \times b) - (a \times x) =$

- (A) $ab + ax$ (B) $ab - ax$ (C) $a^2 - bx$ (D) $a^2 + bx$

13) If $a = 4$, $b = 3$ and $c = 2$, find the value of $\left(\frac{a}{b}\right)^x$

- (A) $\frac{4}{3}$ (B) $\frac{8}{6}$ (C) $\frac{8}{9}$ (D) $\frac{16}{9}$

14) Solve $10(2x - 4) = 80$

- (A) 6 (B) 8 (C) 10 (D) 12

15) If $m = 5$ and $n = 6$, find the value of $\frac{m^2 + 4n}{mn}$

(A) $\frac{29}{30}$

(B) $\frac{25}{30}$

(C) $\frac{49}{30}$

(D) $\frac{39}{30}$

16) Add 3 to a number x and divide the result by 4. Write this statement in algebraic form.

(A) $x + 3 \div 4$

(B) $\frac{x + 3}{4}$

(C) $3 + x \div 4$

(D) $\frac{x}{4}$

17) Solve $3(5 + x) = 27$

(A) -4

(B) 2

(C) 3

(D) 4

18) $2\frac{2}{3} + x = 5$ What is the value of x ?

(A) $2\frac{1}{3}$

(B) $2\frac{2}{3}$

(C) $1\frac{2}{3}$

(D) $3\frac{2}{3}$

19) $-3(x - 7) =$

(A) $-3x - 21$

(B) $3x + 21$

(C) $-3x + 21$

(D) $3x - 21$

20) Solve: $8 \leq 2x \leq 12$

(A) $4 < x < 6$

(B) $4 \leq x \leq 6$

(C) $2x \leq 4$

(D) $2x \leq 20$

TEST 3

1)



Cost of pencil = \$ m

Cost of pen = \$2

Find the cost of 8 pens and 20 pencils.

- (A) \$(16 + 20 m) (B) \$28 m (C) \$32 m (D) \$(16 m + 20 m)

2) $6a^3 \times 3a^7 =$

- (A) $63a^3$ (B) $63a^7$ (C) $18a^3$ (D) $18a^{10}$

3) If $x = -2$, find the value of $\frac{x^3}{3-x}$

- (A) $1\frac{3}{5}$ (B) $-1\frac{3}{5}$ (C) $-2\frac{3}{5}$ (D) $2\frac{3}{5}$

4) Solve $7y - 20 = 5y + 40$

- (A) -30 (B) 20 (C) 30 (D) 15

5) Fiaz has x baseball cards. Nalini has three times as many cards. Nalini gave Fiaz 7 of her cards. How many cards Nalini now has?

- (A) $x - 7$ (B) $3x + 7$ (C) $4x - 7$ (D) $3x - 7$

6) Solve $3(x - 8) = 21$

- (A) 15 (B) 32 (C) 3 (D) 8

7) $(x - 7)(2x + 3) =$

(A) $2x^2 - 11x - 21$ (B) $2x^2 + 11x - 21$

(C) $2x^2 - 11x + 21$ (D) $2x^2 + 11x + 21$

8) Solve $10x - 35 = 9x + 4$

(A) 30 (B) 20 (C) 39 (D) 35

9) $8m^4 \times 4m^8 =$

(A) $32m^4$ (B) $32m^{12}$ (C) $32m^8$ (D) $12m^{12}$

10) If $m = -3$, find the value of $\frac{m^3}{4 - m}$

(A) $-3\frac{6}{7}$ (B) $3\frac{6}{7}$ (C) $\frac{6}{7}$ (D) $\frac{27}{7}$

11) Solve $3x + 4 \geq 13$

(A) $x \geq 4$ (B) $x \geq 2$ (C) $x \geq 3$ (D) $x \geq 5$

12) Mike has y bandanas. Joe has twice as many. Find their total number of bandanas.

(A) $3y^2$ (B) $2y$ (C) $4y$ (D) $3y$

13) $5 + \frac{3}{x} = 2$ Find x

(A) 9 (B) -1 (C) 3 (D) 2

14) Solve the pair of simultaneous equations $2x - y = 17$ and $x - y = 10$

(A) $x = 7$ and $y = -3$ (B) $x = -7$ and $y = 3$

(C) $x = -7$ and $y = -3$ (D) $x = 5$ and $y = 3$

15) $10 < 2x \leq 20$ Find x

(A) $5 \leq x \leq 10$ (B) $x \leq 10$ (C) $x \leq 30$ (D) $5 < x \leq 10$

16) $-8(2x - 3) =$

(A) $-16x + 24$ (B) $-8x + 24$ (C) $16x + 24$ (D) $-16x - 24$

17) $2x(x + 3y) - y(2x - y) =$

(A) $2x^2 + 8xy + y^2$ (B) $2x^2 + 4xy + y^2$

(C) $2x^2 + 8xy - y^2$ (D) $2x + 4xy + y$

18) Solve $4(x - 2) - 3(x - 2) = 25$

(A) 25 (B) 20 (C) 30 (D) 27

19) Subtract p from 10 and multiply the result by 2. Which expression represents this statement?

(A) $10 - p \times 2$ (B) $p - 10 \times 2$ (C) $2(10 - p)$ (D) None of the above

20) Two numbers give 32 when added and give 4 when subtracted. Write simultaneous equations to represent this.

(A) $x + y = 32$ and $x - y = 4$ (B) $x - y = 32$ and $x + y = 4$

(C) $x + y = 36$ and $x - y = 28$ (D) $32 + 4 = x$ and $32 - 4 = y$

TEST 4

1) $(6x)^2 =$

- (A)
- $12x^2$
- (B)
- $36x^2$
- (C)
- $6x^2$
- (D)
- $12x$

2) $(2x + 2)(x - 1) =$ What is the coefficient of x^2

- (A) 1 (B) 2 (C) 3 (D) 4

3) $4(x + y) - 2(x - y) =$

- (A)
- $2x + 6y$
- (B)
- $4x + 4y$
- (C)
- $4x + 6y$
- (D)
- $2x - 6y$

4) $\frac{2x}{5y} + \frac{4x}{3y} =$

- (A)
- $\frac{6x}{8y}$
- (B)
- $\frac{8x}{15y}$
- (C)
- $\frac{26x}{5y}$
- (D)
- $\frac{26x}{15y}$

5) Solve $5x + 4 \geq 12$

- (A)
- $x = 1\frac{3}{5}$
- (B)
- $x \geq 2\frac{3}{5}$
- (C)
- $x \geq 1\frac{3}{5}$
- (D)
- $x \geq 1\frac{2}{5}$

6) Find $\left(\frac{m}{n}\right)^a$ when $m = 2$, $n = 3$ and $a = 3$

- (A)
- $\frac{4}{9}$
- (B)
- $\frac{8}{27}$
- (C)
- $\frac{4}{27}$
- (D)
- $\frac{6}{9}$

7) Add 11 to a number and divide the sum by 5. The result of this is 10. Write this statement in algebra.

- (A)
- $\frac{11+x}{5} = 10$
- (B)
- $11 + x \div 5 = 10$
- (C)
- $11 + x/5 = 10$
- (D)
- $11 + x = 10$

8) Solve the pair of simultaneous equations $2x - y = 1$ and $2x + 2y = 10$

(A) $x = -2, y = -3$ (B) $x = 3, y = 2$

(C) $x = -2, y = -3$ (D) $x = 2, y = 3$

9) $(3x - 2)(x + 1) =$

(A) $x^2 + x - 2$ (B) $3x + x - 2$ (C) $3x^2 + x - 2$ (D) $3x^2 + 5x - 2$

10) Watermelons are sold for d cents per pound. The total weight of three watermelons is 20 pounds. What is the average cost of one watermelon?

(A) $\frac{d}{3}$ (B) $\frac{20d}{3}$ (C) $\frac{20}{3}$ (D) $\frac{d}{20}$

11) Solve for x in the equation $2x + 6 = 7$

(A) $\frac{1}{2}$ (B) $6\frac{1}{2}$ (C) 1 (D) 3

12) $5(x + y) - 3(x - y) =$

(A) $5x + 3y$ (B) $8x + 8y$ (C) $8x + 5y$ (D) $2x + 8y$

13) The area of this trapezium is 128 cm^2 . Which expression can be used to connect this area with the given measurements?

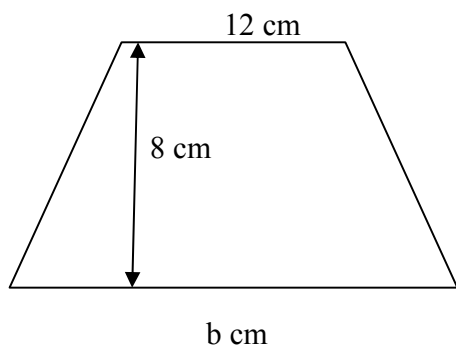

(A) $b \times 8 = 128$ (B) $\frac{(12+b)}{2} \times \frac{8}{1} = 128$ (C) $b \times 8 \times 12 = 128$ (D) $\frac{(12 \times 8)}{b} = 128$

14) The area of the trapezium is $A \text{ cm}^2$. Which expression is correct?

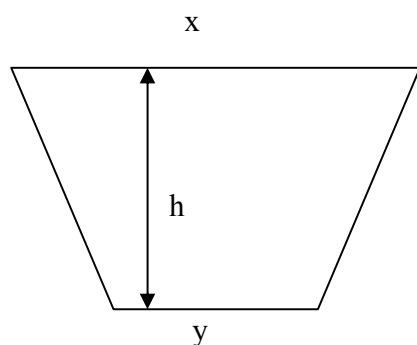

(A) $x \times y \times h = A$

(B) $\frac{(x \times y)}{2} \times \frac{h}{1} = A$

(C) $\frac{(x + y)}{2} \times \frac{h}{1} = A$

(D) $\frac{(x \times y)}{2} + \frac{h}{1} = A$

15) $2(x - 1) - 3x = 6$ Solve this equation

(A) -8

(B) 8

(C) 4

(D) -4

16) Eight times the product of two numbers x and y is

(A) $8 + x + y$

(B) $xy \div 8$

(C) $8(x + y)$

(D) $8xy$

17) $3m^2n^3 \times 4mn^2 =$

(A) $12m^2n^5$

(B) $12m^3n^5$

(C) $12m^2n^3$

(D) $12mn$

18) $\frac{3x+1}{2} - \frac{x+1}{4} =$

(A) $\frac{7x+3}{4}$

(B) $\frac{2x+2}{4}$

(C) $\frac{5x+1}{4}$

(D) $\frac{5x+2}{4}$

19) Find m if $\frac{1}{m} = \frac{1}{3} + \frac{1}{4}$

(A) $\frac{12}{7}$

(B) $\frac{7}{12}$

(C) $\frac{2}{7}$

(D) $\frac{7}{2}$

20) $\frac{4x + 8}{2} =$

(A) $x + 4$

(B) $2x + 8$

(C) $6x$

(D) $2x + 4$

TEST 5

1)

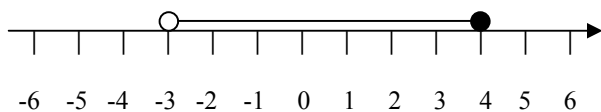

Which inequality represents the solution set shown on the number line?

- (A) $-3 \leq x \leq 4$ (B) $-3 < x \leq 4$ (C) $-3 \leq x < 4$ (D) $x \leq 4$

2)

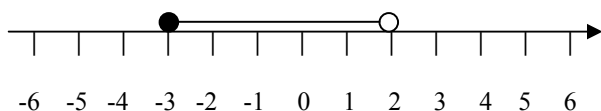

Which inequality represents the solution set shown on the number line?

- (A) $-3 \leq x \leq 2$ (B) $-3 \geq x \geq 2$ (C) $x \geq -3$ (D) $-3 \leq x < 2$

3)

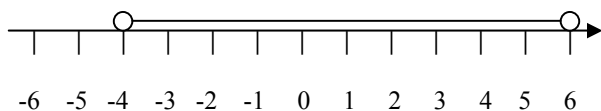

Which inequality represents the solution set shown on the number line?

- (A) $-4 \leq x \leq 6$ (B) $x \leq 6$ (C) $-4 < x < 6$ (D) $-4 \leq x$

4)

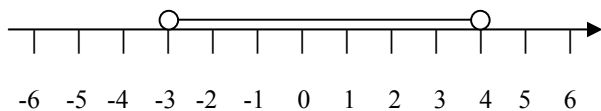

Which inequality represents the solution set shown on the number line?

- (A) $-3 < x < 4$ (B) $-3 \leq x \leq 4$ (C) $-3 \leq x$ (D) $x \leq 4$

5)

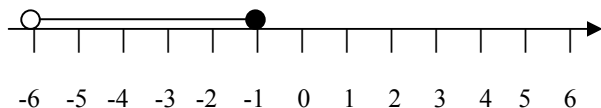

Which inequality represents the solution set shown on the number line?

- (A) $-6 \leq x \leq -1$ (B) $x \leq -1$ (C) $-6 \leq x$ (D) $-6 < x \leq -1$

6)

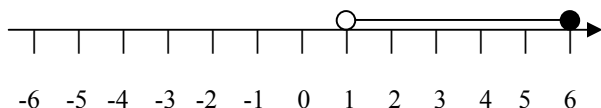

Which inequality represents the solution set shown on the number line?

- (A) $1 \leq x \leq 6$ (B) $x \leq 6$ (C) $1 < x \leq 6$ (D) $1 < x$

7)

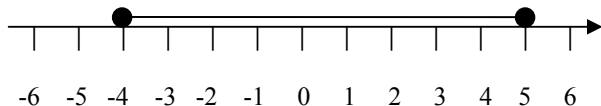

Which inequality represents the solution set shown on the number line?

- (A) $-4 < x < 5$ (B) $x \leq 5$ (C) $-4 \leq x$ (D) $-4 \leq x \leq 5$

8)



Which inequality represents the solution set shown on the number line?

- (A) $-6 < x < 4$ (B) $-6 \leq x \leq 4$ (C) $x \leq 4$ (D) $-6 \leq x$

9)

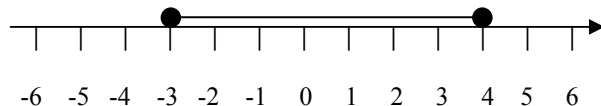

Which inequality represents the solution set shown on the number line?

- (A) $-3 \leq x \leq 4$ (B) $-3 < x < 4$ (C) $x \leq 4$ (D) $-3 \leq x$

10)



Which inequality represents the solution set shown on the number line?

- (A) $-2 \leq x \leq 5$ (B) $x \leq 5$ (C) $-2 < x$ (D) $-2 < x \leq 5$

11) Draw a number line to represent the solution set $\{x : -1 \leq x \leq 5\}$

12) Draw a number line to represent the solution set $\{x : 5 \leq x < 12\}$

13) Draw a number line to represent the solution set $\{x : -5 \leq x \leq 3\}$.

14) Draw a number line to represent the solution set $\{x : -3 < x < 5\}$

15) Draw a number line to represent the solution set $\{x : -6 \leq x \leq 1\}$

16) Draw a number line to represent $x > 7$?

17) Draw a number line to represent $x \leq 2$

18) Solve the inequality and represent the solution set on a number line $2x - 1 < 5$

19) Solve the inequality and represent the solution set on a number line $3x + 2 \geq 11$

20) Solve the inequality and represent the solution set on a number line $4x + 2 > 14$

4 Sets

TEST 1

1) How many subsets can be obtained from $A = \{a, b, c\}$?

- (A) 2 (B) 4 (C) 6 (D) 8

2) $U = \{1, 2, 3, 4, 5, 6, 7, 8, 9, 10\}$, $B = \{2, 4, 6, 8, 10\}$. What is B' ?

- (A) $\{1, 3, 5, 7, 9\}$ (B) $\{1, 3, 5\}$ (C) $\{2, 4, 6, 8, 10\}$ (D) $\{5, 7, 9\}$

3) $A = \{1, 3, 5, 7, 9\}$, $B = \{1, 2, 3, 4, 5\}$ and $C = \{3, 4, 5, 6, 7\}$. List $A \cap B \cap C$

- (A) $\{1, 3, 5\}$ (B) $\{1, 3, 5, 7\}$ (C) $\{3, 5\}$ (D) $\{2, 3, 5\}$

4) $A = \{a, b, c, d, e\}$, $B = \{a, e, i, o, u\}$ and $C = \{a, e, y, z\}$. List $A \cap B \cap C$

- (A) $\{a, e, i\}$ (B) $\{a, b, e, i\}$ (C) $\{\}$ (D) $\{a, e\}$

5) $U = \{a, b, c, d, e, f, g, h\}$ and $M = \{a, e, h\}$. List M'

- (A) $\{\}$ (B) $\{b, c, d, f, g\}$ (C) $\{a, e, h\}$ (D) $\{b, c, d, f, g, h\}$

6) $P = \{2, 3, 5, 7, 11\}$, $Q = \{1, 3, 5, 7, 9, 11\}$ and $R = \{2, 4, 6, 8, 10\}$. Which one of the following will give an empty set?

- (A) $Q \cap R$ (B) $P \cap Q$ (C) $P \cap R$ (D) $R \cup P$

7) $Z = \{3, 6\}$. How many subsets can be listed from Z ?

- (A) 1 (B) 2 (C) 3 (D) 4

8) $L = \{2, 4, 6\}$ and $M = \{2, 4\}$. Which statement is true?

- (A) $L \subset M$ (B) $L \cup M = M$ (C) $M \cap L = \{\}$ (D) $L \cap M = M$

9) $M = \{10, 11, 12, 13\}$ and $N = \{10, 12, 14\}$. List $M \cup N$

- (A) $\{10, 11, 12, 13\}$ (B) $\{10, 12\}$ (C) $\{10, 11, 12, 13, 14\}$ (D) $\{10, 12, 14\}$

10) $Y = \{\text{factors of } 12\}$ and $Z = \{\text{factors of } 8\}$. List $A \cap B$

- (A) $\{1, 2, 4\}$ (B) $\{1, 2, 4, 8\}$ (C) $\{2, 4\}$ (D) $\{1, 4\}$

11) $A = \{1, 2, 3, 4\}$. Which is **equivalent** to A?

- (A) $\{1, 2, 3, 4\}$ (B) $\{2, 4\}$ (C) $\{1, 4\}$ (D) $\{a, b, c, d\}$

12) How many subsets can be formed from $B = \{p, q, r, s\}$

- (A) 8 (B) 12 (C) 16 (D) 20

13) Which is equal to $B = \{2, 4, 6, 8\}$

- (A) $\{a, b, c, d\}$ (B) $\{8, 6, 4, 2\}$ (C) $\{2, 4, 6\}$ (D) $\{4, 6, 8\}$

14) $U = \{a, e, i, o, u\}$. List Z' if $Z = \{a, u\}$

- (A) $\{e, i, o\}$ (B) $\{a, e, i, o, u\}$ (C) $\{a, e, i\}$ (D) $\{a, e\}$

15) How many subsets can be formed from $D = \{l, m, n, o\}$?

- (A) 4 (B) 8 (C) 16 (D) 12

16) Shade $A \cap B$ with your pencil.

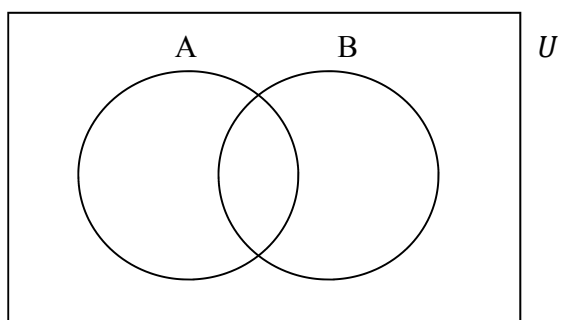

17) Shade $A \cup B$ with your pencil

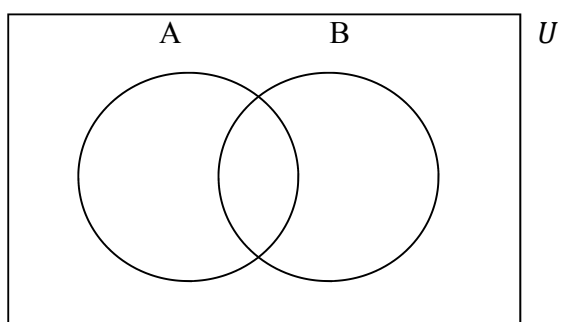

18) Shade the set A.

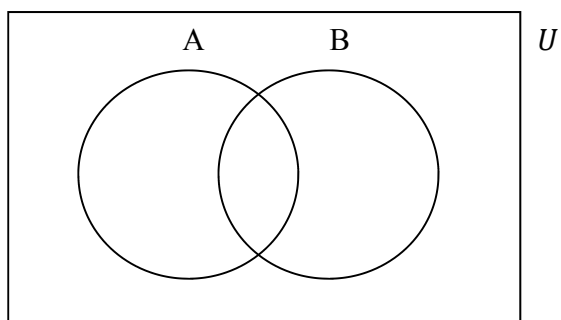

19) Shade the set B .

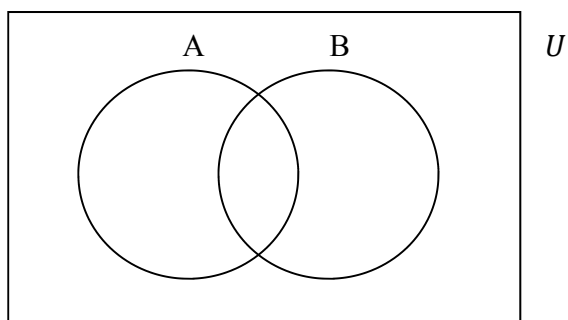

20) Shade the set A'

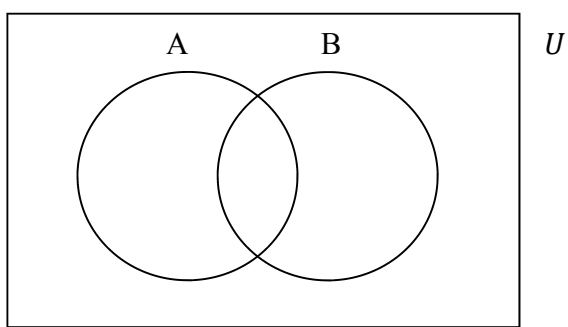

TEST 2

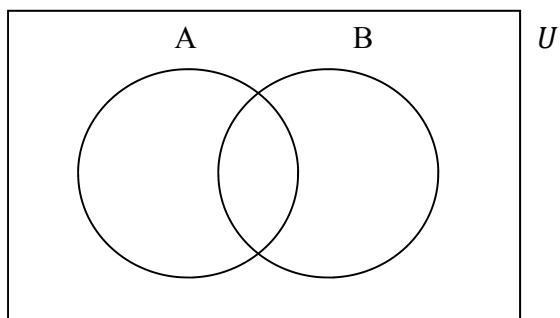
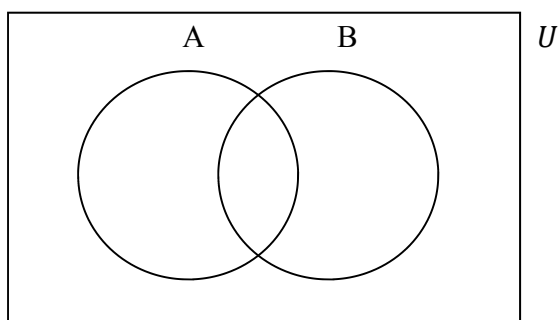
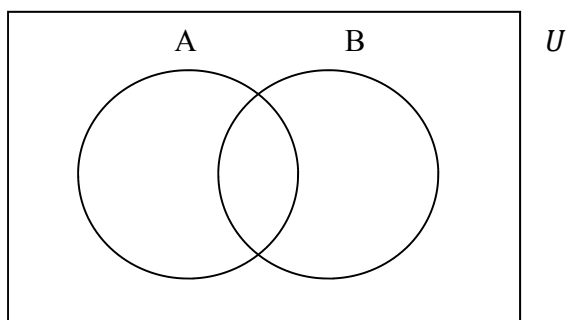
1) Shade the set B' 2) Shade $(A \cap B)'$ 3) Shade $(A \cup B)'$ 

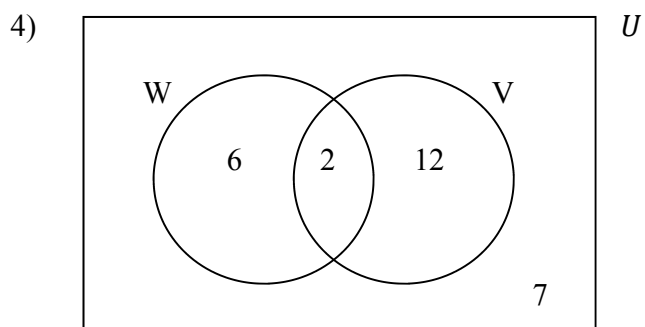

$W = \{\text{students who use WhatsApp}\}$ and $V = \{\text{students who use Viber}\}$

How many students do not use Viber?

- (A) 6 (B) 7 (C) 15 (D) 13

5) Which one represents the shaded area?

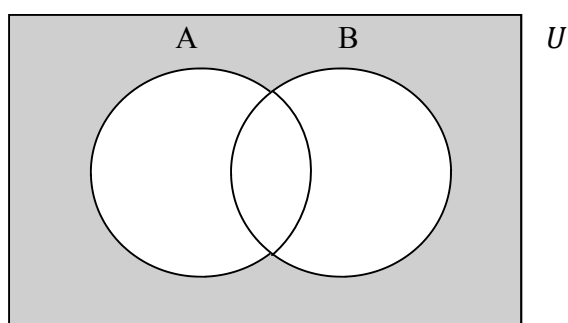

- (A) $(A \cap B)$ (B) $(A \cup B)$ (C) $(A \cap B)'$ (D) $(A \cup B)'$

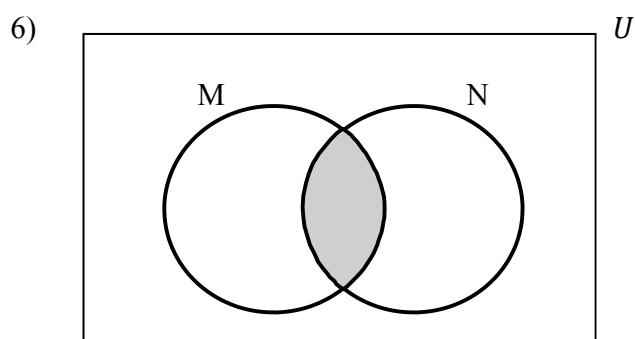

$M = \{1, 2, 3, 4, 5, 6, 7\}$ and $N = \{2, 4, 6, 8, 10\}$. Which elements are located in the shaded region?

- (A) $\{2, 4, 6\}$ (B) $\{1, 2, 3, 4, 5, 6, 7, 8, 10\}$ (C) $\{2, 4, 6, 8, 10\}$ (D) $\{\}$

7) If $A = \{1, 2, 3, 4, 5, 6, 7\}$ and $B = \{2, 4, 6, 8, 10\}$, what is represented by the shaded region?

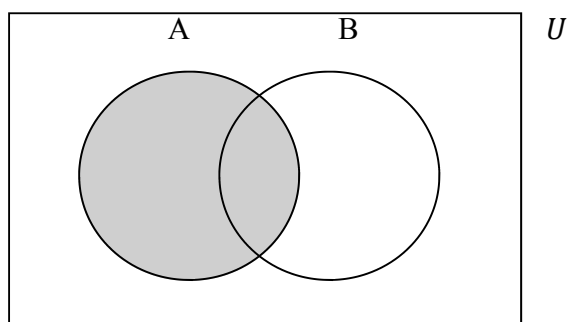

- (A) $\{2, 4, 6, 8, 10\}$ (B) $\{1, 2, 3, 4, 5, 6, 7\}$ (C) $\{2, 4, 6\}$ (D) $\{1, 2, 3, 4, 5, 6, 7, 8, 10\}$

8) How many students do not play football?

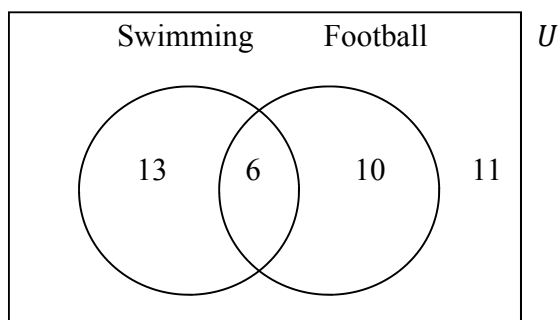

- (A) 11 (B) 30 (C) 6 (D) 24

9) What percentage takes both Netflix and Cable?

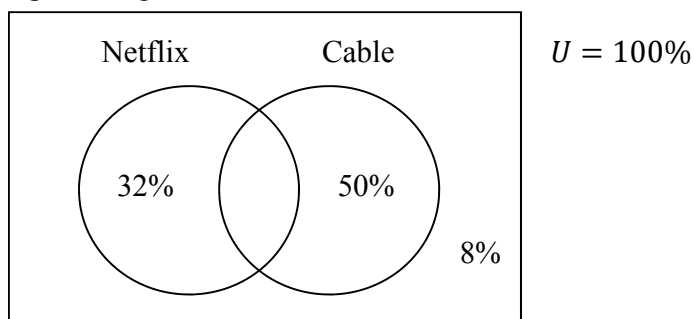

- (A) 82% (B) 8% (C) 10% (D) 100%

10) The shaded region represents

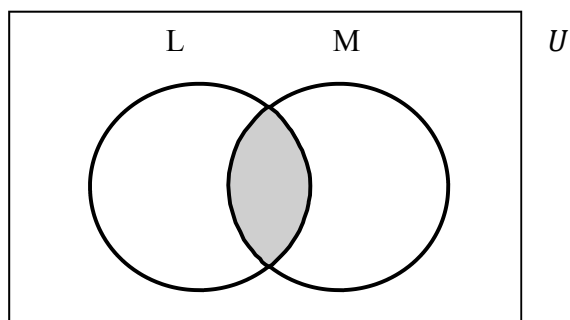

- (A) $L \cap M$ (B) $L \cup M$ (C) $L \text{ and } M$ (D) $L \text{ or } M$

11)

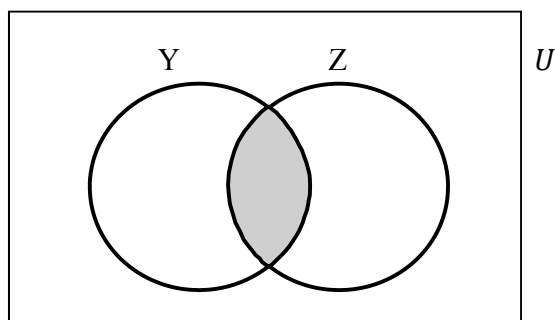

$Y = \{\text{factors of } 12\}$ and $Z = \{\text{factors of } 8\}$. List the members in the shaded region.

- (A) $\{1, 2, 3, 4, 6, 12\}$ (B) $\{1, 2, 4\}$ (C) $\{1, 2, 4, 8\}$ (D) $\{8, 12\}$

12)

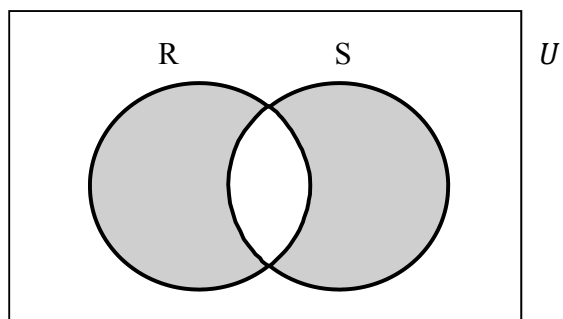

$R = \{\text{factors of } 20\}$ and $S = \{\text{factors of } 16\}$. List the members in the shaded region.

- (A) $\{1, 2, 4\}$ (B) $\{10, 16, 20\}$ (C) $\{16, 20\}$ (D) $\{5, 8, 10, 16, 20\}$

13)

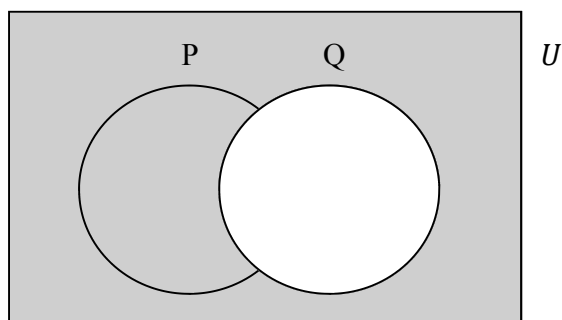

Which one represents the white region?

- (A) U (B) P (C) Q (D) $P \cap Q \cap U$

14)

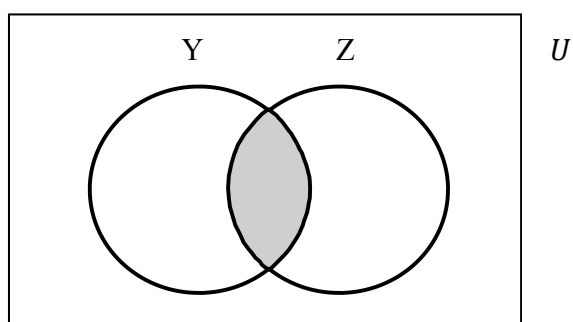

$Y = \{\text{factors of } 40\}$ and $Z = \{\text{factors of } 50\}$. List the members in the shaded region.

- (A) $\{1, 2, 5, 10\}$ (B) $\{1, 2, 5, 10, 50\}$ (C) $\{4, 10, 40\}$ (D) $\{40, 50\}$

15)

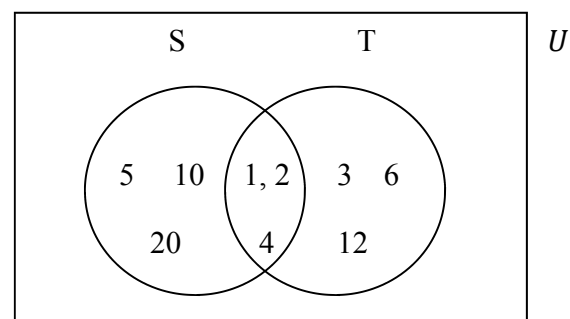

List $S \cap T$

- (A) $\{5, 10, 20\}$ (B) $\{3, 6, 12\}$ (C) $\{10, 12\}$ (D) $\{1, 2, 4\}$

16) In a class of 50 students, 35 study politics and 23 study International Relations. How many study BOTH subjects?

- (A) 8 (B) 15 (C) 27 (D) 58

17) $n(A) = 12$, $n(A \cap B) = 5$ and $n(A \cup B) = 20$, find $n(B)$

- (A) 8 (B) 13 (C) 15 (D) 3

18) In a class of 40 students, 30 study Psychology and 20 study Sociology. How many study BOTH subjects?

- (A) 50 (B) 15 (C) 10 (D) 20

19) $\{x \in A: -2 \leq x < 4\}$. Which set represents this notation?

- (A) $\{-2, 4\}$ (B) $\{-2, -1, 0, 1, 2, 3, 4\}$
(C) $\{-2\}$ (D) $\{-2, -1, 0, 1, 2, 3\}$

20) $\{x \in B: -3 < x \leq 5\}$. Which set represents this notation?

- (A) $\{-2, -1, 0, 1, 2, 3, 4, 5\}$ (B) $\{-3, -2, -1, 0, 1, 2, 3, 4, 5\}$
(C) $\{-2, -1, 0, 1, 2, 3, 4\}$ (D) $\{-3, 5\}$

TEST 3

1) In a class of 60 students, 40 play football and 25 play cricket. How many play BOTH sports?

- (A) 5 (B) 20 (C) 35 (D) 65

2) $\{x \in D: -3 \leq x \leq 7\}$. Which set represents this notation?

- (A) $\{-3, 7\}$ (B) $\{-3, -2, -1, 0, 1, 2, 3, 4, 5, 6\}$
 (C) $\{-3, 0, 7\}$ (D) $\{-3, -2, -1, 0, 1, 2, 3, 4, 5, 6, 7\}$

3) Out of 20 Teachers, 15 use WhatsApp and 11 use Viber. How many use both?

- (A) 26 (B) 5 (C) 6 (D) 9

4) Which one describes the shaded region?

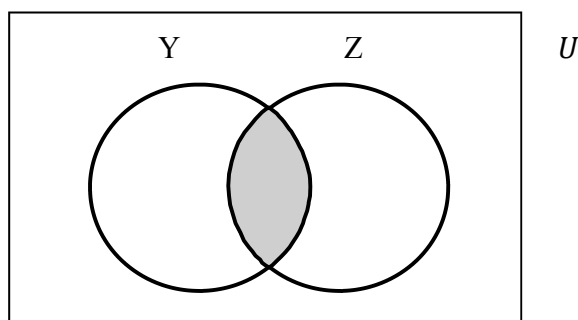

- (A) $Y \cup Z$ (B) $Y \cap Z$ (C) Y' (D) Z'

5) Which one describes the shaded region?

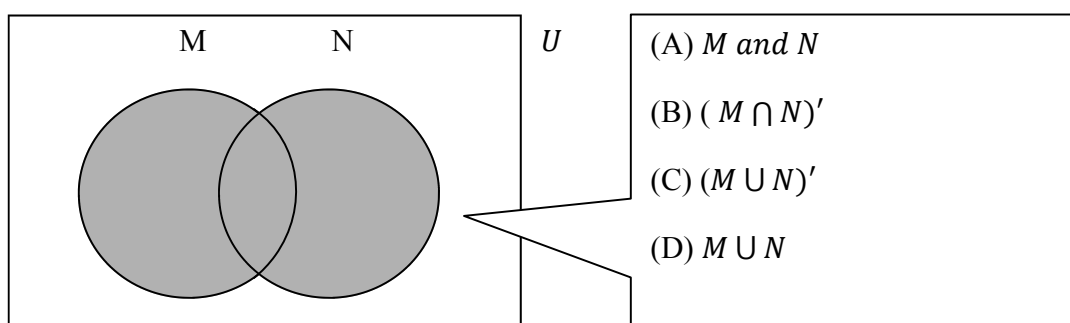

- (A) M and N
 (B) $(M \cap N)'$
 (C) $(M \cup N)'$
 (D) $M \cup N$

6) Which is the best description of the shaded region?

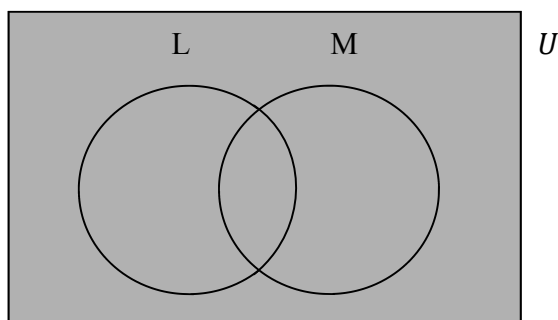

- (A) $L \cup M$ (B) $L \cap M$ (C) The universal set (D) L, M, U

7) The shaded region represents

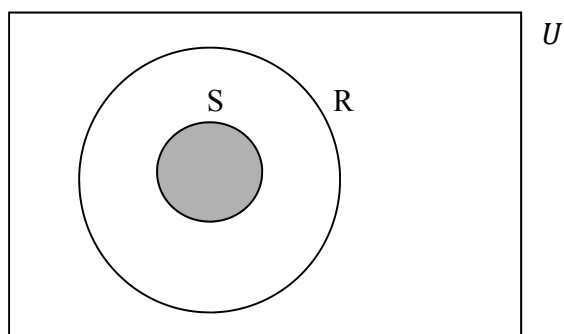

- (A) $S \subset R$ (B) $R \subset S$ (C) $S \cap U$ (D) $R \subset U$

8) Which is an infinite set?

- (A) {odd numbers between 10 and 20}
 (B) {prime numbers between 10 and 20}
 (C) {factors of 20}
 (D) {multiples of 20}

14) $(A \cap B)' =$

(A) $\{1, 2, 3, 4, 5, 6, 8, 10\}$

(B) $\{1, 2, 3, 4, 5\}$

(C) $\{2, 4, 6, 8, 10\}$

(D) $\{8, 10, 6, 1, 3, 5, 7, 9\}$

15) $(A \cup B)' =$

(A) $\{7, 9\}$

(B) $\{1, 2, 3, 4, 5\}$

(C) $\{2, 4, 6, 8, 10\}$

(D) $\{2, 4\}$

16) $n(A) =$

(A) 3

(B) 2

(C) 5

(D) 7

17) $n(B) =$

(A) 7

(B) 2

(C) 3

(D) 5

18) $n(A \cap B) =$

(A) 3

(B) 2

(C) 5

(D) 7

19) $n(A \cup B) =$

(A) 8

(B) 10

(C) 5

(D) 3

20) $n(A \cap B)' =$

(A) 2

(B) 3

(C) 5

(D) 8

21) $n(A \cup B)' =$

(A) 3

(B) 5

(C) 2

(D) 1

TEST 4

QUESTIONS 1 TO 12 ARE BASED ON THE VENN DIAGRAM.

$U = \{a, b, c, d, e, f, g, h, i, j, o, u\}$, $A = \{a, e, i, o, u\}$ and $B = \{e, f, g, h, i, j\}$

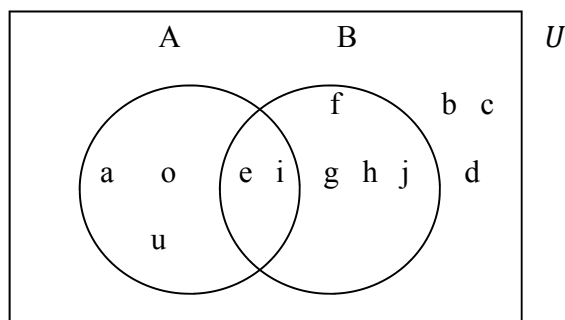

1) $A \cap B =$

- (A) $\{e, f, g, h, i, j\}$ (B) $\{a, e, i, o, u\}$ (C) $\{e, i\}$ (D) $\{b, c, d, f\}$

2) $A \cup B =$

- (A) $\{a, o, u, e, i, f, g, h, j\}$ (B) $\{a, e, i, o, u\}$ (C) $\{e, i\}$ (D) $\{b, c, d, f\}$

3) $A' =$

- (A) $\{f, g, h, j, b, c, d\}$ (B) $\{a, o, u, b, c, d, f\}$ (C) $\{e, i\}$ (D) $\{b, c, d, f\}$

4) $B' =$

- (A) $\{e, f, g, h, i, j\}$ (B) $\{a, o, u, b, c, d\}$ (C) $\{e, i\}$ (D) $\{b, c, d, f\}$

5) $(A \cap B)' =$

- (A) $\{e, f, g, h, i, j\}$ (B) $\{a, o, u, b, c, d, f\}$
 (C) $\{a, o, u, f, g, h, j, b, c, d\}$ (D) $\{b, c, d, f\}$

6) $(A \cup B)' =$

- (A) $\{e, f, g, h, i, j\}$ (B) $\{a, e, i, o, u\}$ (C) $\{e, i\}$ (D) $\{b, c, d\}$

7) $n(A) =$

- (A) 3 (B) 5 (C) 8 (D) 7

8) $n(B) =$

- (A) 6 (B) 5 (C) 8 (D) 7

9) $n(A \cap B) =$

- (A) 3 (B) 5 (C) 2 (D) 7

10) $n(A \cup B) =$

- (A) 3 (B) 9 (C) 8 (D) 7

11) $n(A \cap B)' =$

- (A) 3 (B) 5 (C) 8 (D) 10

12) $n(A \cup B)' =$

- (A) 3 (B) 5 (C) 8 (D) 7

13) $Y = \{\text{factors of } 25\}$ and $Z = \{\text{factors of } 20\}$. List $A \cap B$

- (A) $\{20, 25\}$ (B) $\{5, 20, 25\}$ (C) $\{1, 5\}$ (D) $\{1, 5, 20, 25\}$

14) $P = \{\text{factors of } 12\}$ and $Q = \{\text{factors of } 15\}$. List $P \cup Q$

- (A) $\{1, 3\}$ (B) $\{1, 2, 3, 4, 5, 6, 12, 15\}$
(C) $\{12, 15\}$ (D) $\{1, 3, 5, 15\}$

15) $C = \{\text{the first 5 even numbers}\}$ and $D = \{\text{the first five odd numbers}\}$. List $C \cap D$

- (A) $\{1, 3, 5, 7, 9\}$ (B) $\{2, 4, 6, 8, 10\}$ (C) $\{\}$ (D) $\{1, 2, 9, 10\}$

16) $E = \{w, x, y, z\}$ and $F = \{1, 2, 3, 4, 5\}$. List $E \cap F$

- (A) $\{w, x, y, z, 1, 2, 3, 4, 5\}$ (B) $\{w, x, y, z\}$ (C) $\{1, 2, 3, 4, 5\}$ (D) $\{\}$

17) $G = \{5, 10, 15, 20, 25, 30, 35\}$ and $H = \{30, 35, 40, 45, 50, 55, 60\}$. List $G \cap H$

- (A) $\{30, 35\}$ (B) $\{\}$ (C) G' (D) H'

18) $U = \{2, 4, 6, 8, 10, 12, 14\}$, $I = \{6, 12, 14\}$ and $J = \{4, 8, 12\}$. Draw a Venn diagram to show this information.

19) Which set is empty?

(A) {flying pigs}

(B) {even numbers more than a billion}

(C) {odd numbers more than a trillion}

(D) {a, b, c, 1, 2, 3}

20) Which set is infinite?

(A) {flying pigs}

(B) {even numbers less than a billion}

(C) {odd numbers more than a trillion}

(D) {a, b, c, 1, 2, 3}

5 Measurement

TEST 1

1) Write an expression to represent the area of the trapezium.

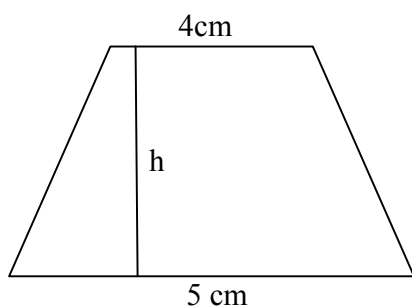

- (A) $A = 5 \times h$ (B) $A = \frac{(5 \times h)}{2}$ (C) $A = (5 + 4) \times h$ (D) $A = \frac{(4+5)}{2} \times \frac{h}{1}$

2) What is the area of the sector OAB?

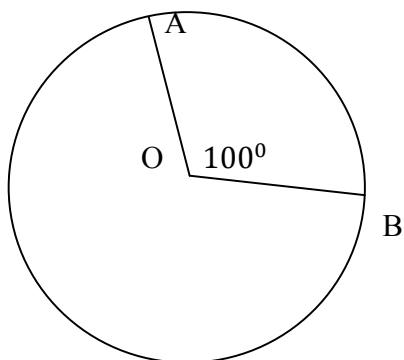

- (A) $\frac{100\pi r^2}{360}$ (B) $A = \pi r^2$ (C) $100 \pi r^2$ (D) $A = \frac{22}{7}$

3) Express 36 millimeters in meters.

- (A) 3.6 (B) 36 (C) 0.036 (D) 0.0036

4) Find the volume.

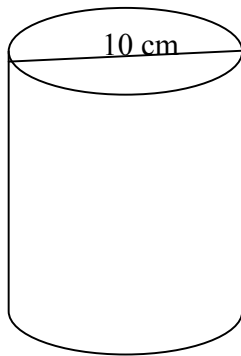

(A) $(10 \times 30 \times \pi) \text{ cm}^3$

(B) $750\pi \text{ cm}^3$

(C) $\frac{10 \times 30}{2} \text{ cm}^3$

(D) $\frac{(10 \times 30)\pi}{2} \text{ cm}^3$

5) Find the circumference

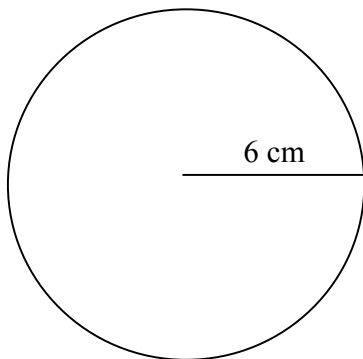

(A) $C = D\pi \text{ cm}^2$

(B) $\frac{22}{7} \times 6 \text{ cm}^2$

(C) 18.9 cm^2

(D) $12\pi \text{ cm}^2$

6) The volume of the cuboid is 768 cm^3 . Find x .

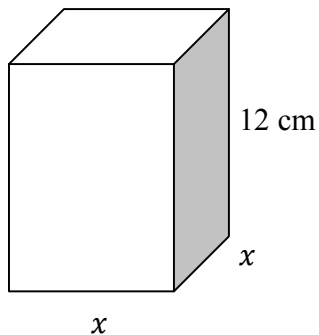

(A) 8 cm

(B) 9 cm

(C) 10 cm

(D) 11 cm

7)

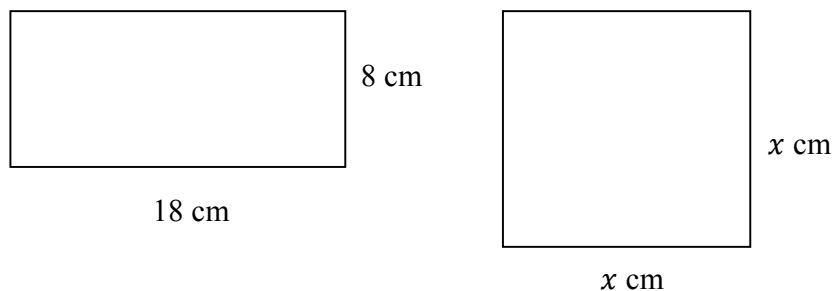

Both shapes have the same area. Find the value of x .

- (A) 9 cm (B) 8 cm (C) 12 cm (D) 18 cm

8) On earth, the largest east to west distance of the Black Sea is 1175 km. On a map this length is 5 cm. What is the scale of the map?

- (A) 1 : 1175 (B) 5 : 1175 (C) 1 : 23,500,000 (D) 1 : 1,175,000

9) How many kilograms are there in 2 metric tonnes?

- (A) 2000 (B) 200 (C) 20,000 (D) 20

10) Find the volume of a cube with an edge that is 4 cm long.

- (A) 12 cm^3 (B) 16 cm^3 (C) 8 cm^3 (D) 64 cm^3

11) Find area.

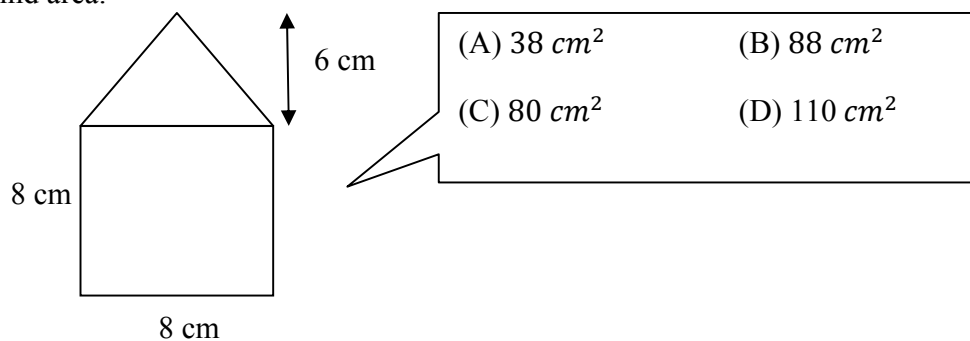

(A) 38 cm^2

(B) 88 cm^2

(C) 80 cm^2

(D) 110 cm^2

12) Find x if the area is 96 cm^2

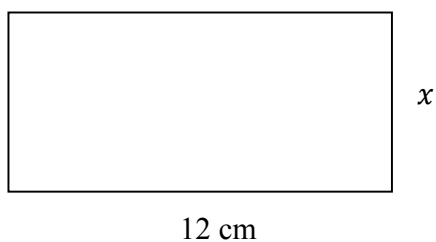

- (A) 8 cm (B) 9 cm (C) 10 cm (D) 11 cm

13) The length of a river is 10 km. On a map this river is represented by 2 cm. What is the scale of this map?

- (A) 2 : 10 (B) 1 : 5 (C) 1 : 500,000 (D) 2 : 100,000

14) If the perimeter of a square is 48.4 cm, find its area.

- (A) 193.6 cm^2 (B) 12.1 cm^2 (C) 96.8 cm^2 (D) 146.41 cm^2

15) Find volume

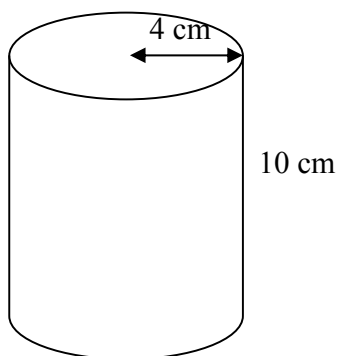

(A) $160 \pi \text{ cm}^3$

(B) $40 \pi \text{ cm}^3$

(C) $80 \pi \text{ cm}^3$

(D) $\frac{22}{7} \pi \text{ cm}^3$

16) A new electric vehicle weighs 3 tonnes and 75 kg. What is this value in kg?

- (A) 375 kg (B) 30075 kg (C) 3.75 kg (D) 3075 kg

17) What is the length of the arc PQ?

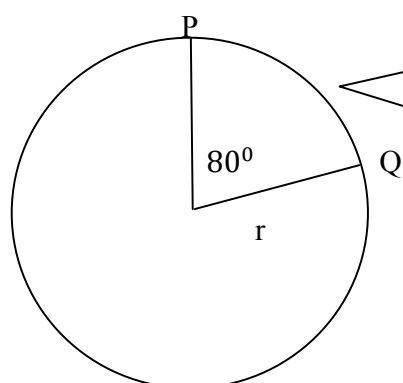

(A) $D\pi\theta$

(B) $2\pi r\theta$

(C) $\frac{4\pi r}{9}$

(D) $\frac{7\pi r}{9}$

18) Find volume

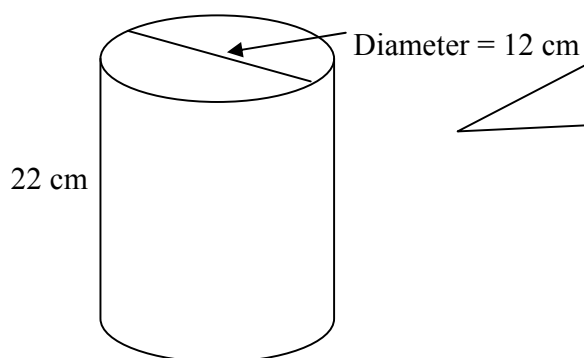

(A) $264\pi \text{ cm}^3$

(B) $792\pi \text{ cm}^3$

(C) $72\pi \text{ cm}^3$

(D) $3168\pi \text{ cm}^3$

19) A sector with an angle of 30° at the center has an arc length of 3 cm. Find the circumference of the circle.

(A) 36 cm

(B) 90 cm

(C) 10 cm

(D) 3π cm

20) Area = 300 cm^2 . Find x .

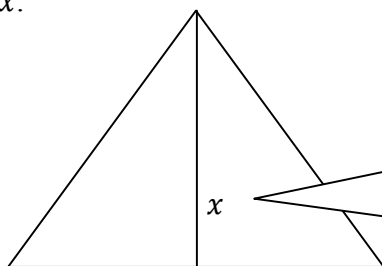

(A) $\text{base} \times x$ (B) $\frac{300}{x}$

(C) $300 \times x$ (D) $\frac{600}{\text{base}}$

TEST 2

1) Find the area of a square if its perimeter is 100 cm.

- (A) 40 cm^2 (B) 625 cm^2 (C) 25 cm^2 (D) 400 cm^2

2) What is the diameter of a circle if its circumference is 44 cm?

- (A) $\frac{44}{\pi} \text{ cm}$ (B) $\frac{14}{\pi} \text{ cm}$ (C) $\frac{22}{\pi} \text{ cm}$ (D) $\frac{28}{\pi} \text{ cm}$

3) Find area.

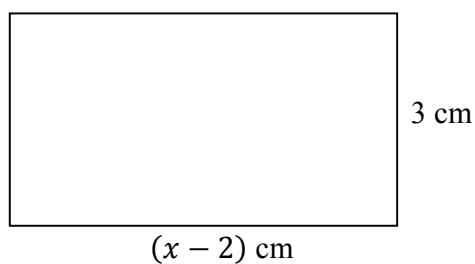

- (A) $(2x - 4) \text{ cm}^2$ (B) $(2x + 10) \text{ cm}^2$ (C) $(2x - 3) \text{ cm}^2$ (D) $(3x - 6) \text{ cm}^2$

4) The area of the circle is 100 cm^2 . What is the area of the minor sector?

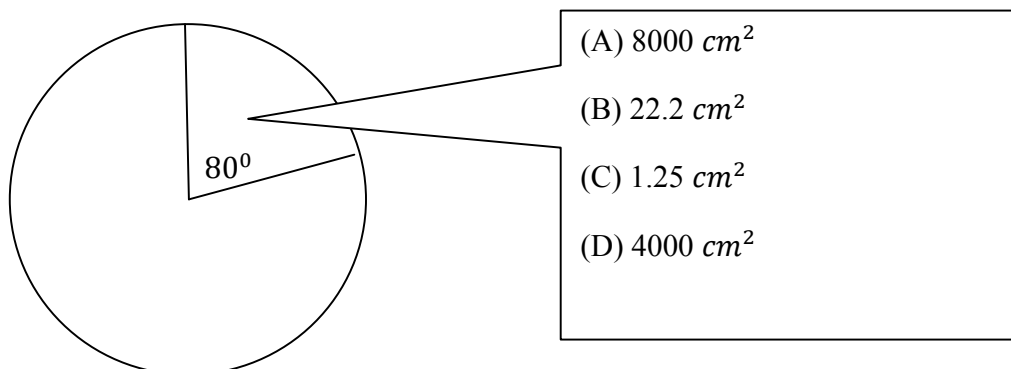

5) Find the volume of the cube.

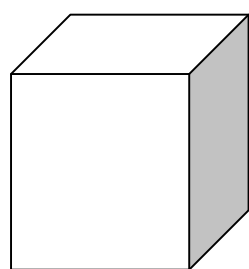

6 cm

(A) 36 cm^3

(B) 216 cm^3

(C) 144 cm^3

(D) 24 cm^3

6)



15 m

20 m

A kitchen garden has dimensions as shown in the diagram. 100 m^2 is used to plant flowers. How much area is left to plant vegetables?

(A) 300 cm^2

(B) 100 cm^2

(C) 200 cm^2

(D) 400 cm^2

7) The area of a rectangle is 225 cm^2 . A square of unknown side has the same area. What is the length of the side of the square?

(A) 15 cm

(B) 22 cm

(C) 25 cm

(D) 5.625 cm

8) What is the area of a sector with angle θ and radius 10 cm?

(A) $\frac{10\pi\theta}{360}$

(B) $\frac{100\pi\theta}{18}$

(C) $\frac{25\pi\theta}{360}$

(D) $\frac{5\pi\theta}{18}$

9) In which shape does the diagonals bisect at right angles.

(A) trapezium

(B) triangle

(C) rhombus

(D) circle

10) Change 7800 millimetres to metres.

- (A) 7.8 m (B) 780 m (C) 78 m (D) 0.78 m

11) Find area

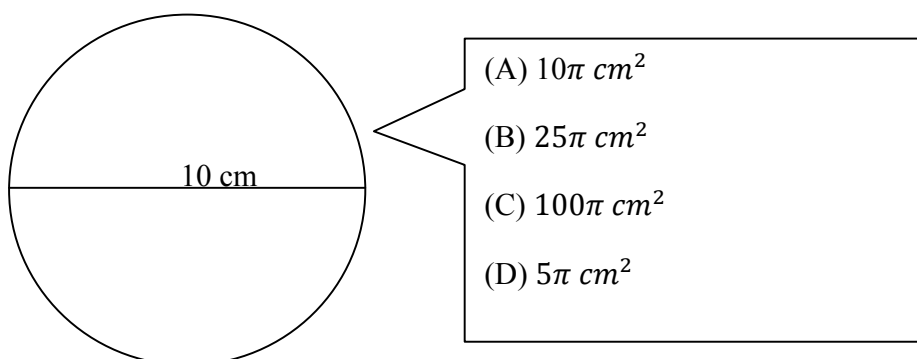

12) Change 14400 seconds to hours.

- (A) 1 h (B) 2 h (C) 3 h (D) 4 h

13) Find the volume of a cube with an edge of length 4 cm.

- (A) 16 cm^3 (B) 12 cm^3 (C) 64 cm^3 (D) 24 cm^3

14) The angle of a sector is 60° and the length of its arc is 10 cm. What is the length of the circumference?

- (A) 60 cm (B) 600 cm (C) 6 cm (D) 300 cm

15) Find area

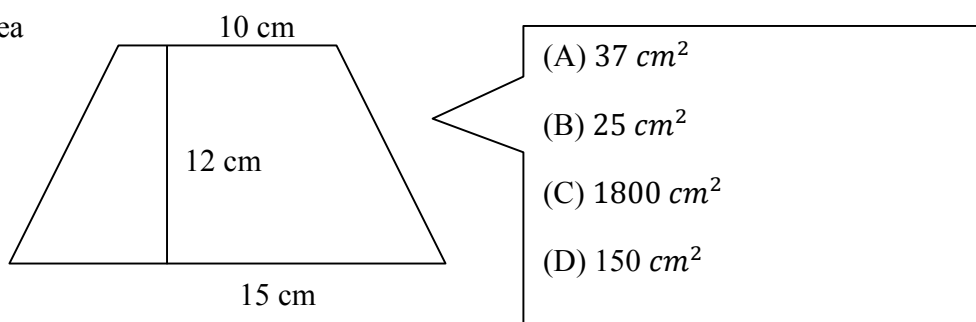

16) Find the area of the figure.

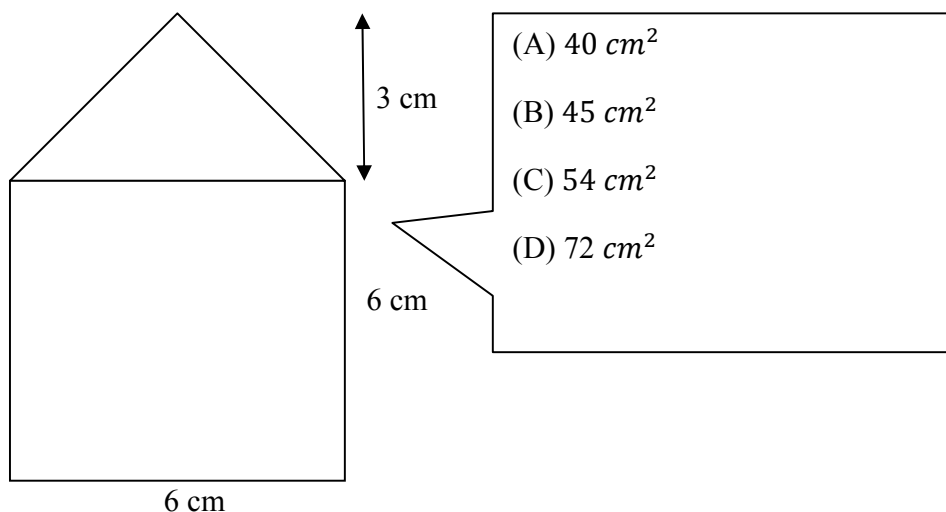

17) Find the volume of a cube with edge 12 cm.

- A) 16 cm^3 (B) 12 cm^3 (C) 1728 cm^3 (D) 24 cm^3

18) Change 3700 millimetres to metres.

- A) 3.7 m (B) 37 m (C) 370 m (D) 0.07 m

19) What is the area of the sector?

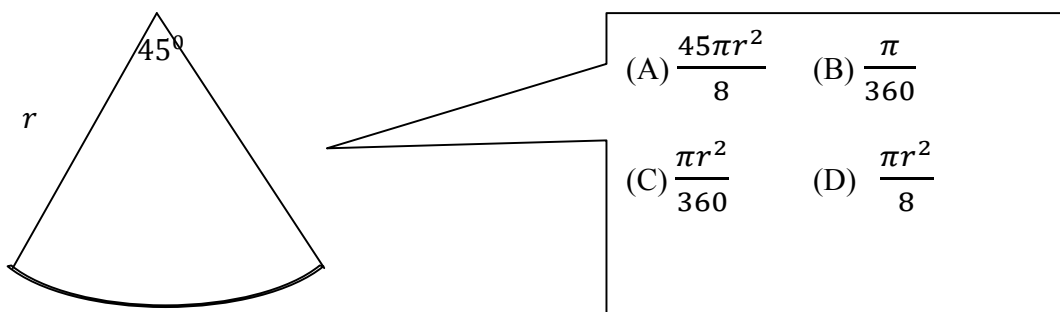

20) Find the radius of a circle which has a circumference of 88 m.

- (A) $\frac{88}{\pi} \text{ m}$ (B) $C = D\pi$ (C) $\frac{44}{\pi} \text{ m}$ (D) 44 m

TEST 3

1) Find the height of a triangle if its area is 120 cm^2 and its base is 12 cm.

- (A) 40 cm (B) 10 cm (C) 60 cm (D) 20 cm

2) Find the area of a square if its perimeter is 52 cm.

- (A) 169 cm^2 (B) 208 cm^2 (C) 13 cm^2 (D) 2704 cm^2

3) Find volume

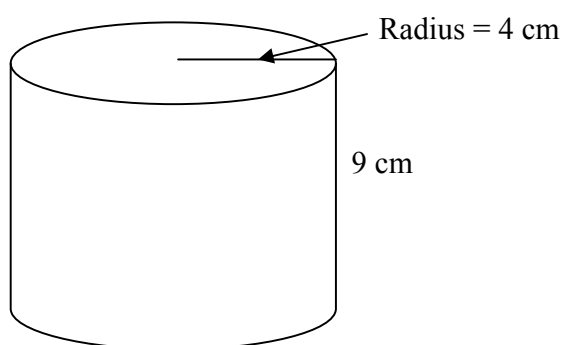

- (A) $36\pi \text{ cm}^3$ (B) $72\pi \text{ cm}^3$ (C) $144\pi \text{ cm}^3$ (D) $18\pi \text{ cm}^3$

4) Find the volume of a cylinder which has a height of 12 cm and a diameter of 8 cm.

- (A) $96\pi \text{ cm}^3$ (B) $48\pi \text{ cm}^3$ (C) $768\pi \text{ cm}^3$ (D) $192\pi \text{ cm}^3$

5) 2 tonnes = x kg. What is the value of x ?

- (A) 20 kg (B) 2000 kg (C) 1000 kg (D) 200 kg

6) Find the radius of a circle which has a circumference of 200 cm.

- (A) $\frac{100}{\pi} \text{ cm}$ (B) $\frac{50}{\pi} \text{ cm}$ (C) $\frac{100}{7\pi} \text{ cm}$ (D) $\frac{200}{7\pi} \text{ cm}$

7) Find area.

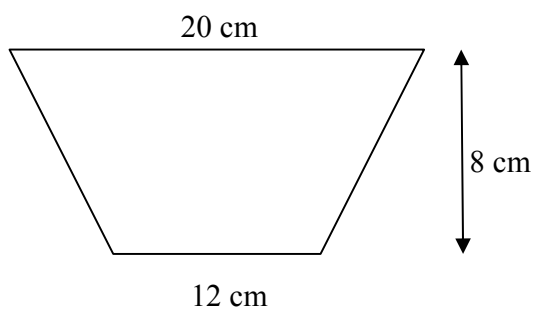

- (A) 256 cm^2 (B) 160 cm^2 (C) 40 cm^2 (D) 128 cm^2

8) Find area.

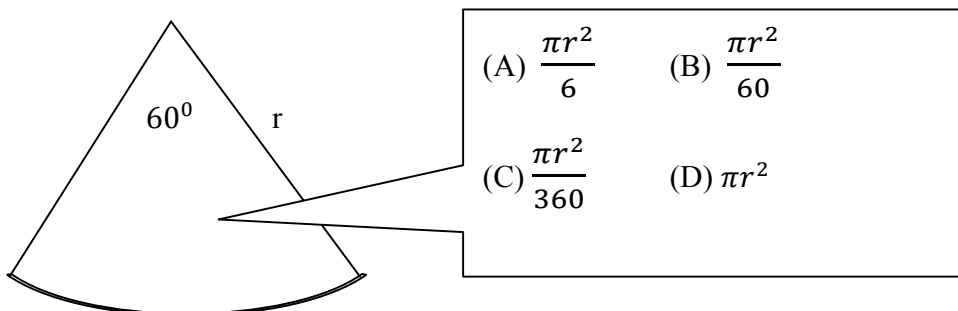

- (A) $\frac{\pi r^2}{6}$ (B) $\frac{\pi r^2}{60}$
 (C) $\frac{\pi r^2}{360}$ (D) πr^2

9) Area = 180 cm^2 . Find base.

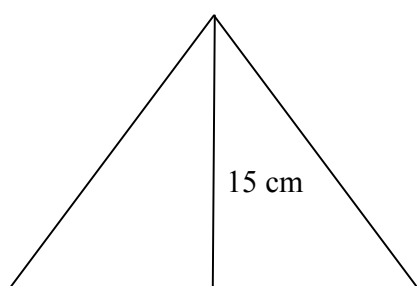

- (A) 12 cm (B) 6 cm
 (C) 24 cm (D) 15 cm

10) Double the length and use half of the width. What is the new area?

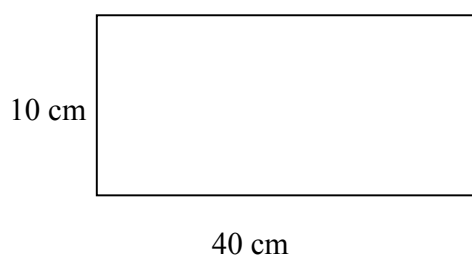

- (A) 200 cm^2 (B) 400 cm^2
 (C) 800 cm^2 (D) 600 cm^2

11) The perimeter of a square is 200 cm , what is its area?

- (A) 2500 cm^2 (B) 800 cm^2 (C) 50 cm^2 (D) 100 cm^2

12) Find volume of the cube.

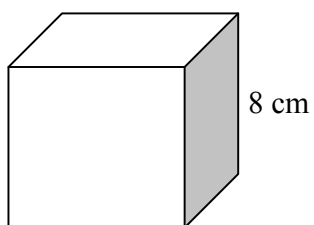

- (A) 24 cm^3 (B) 64 cm^3 (C) 48 cm^3 (D) 512 cm^3

13) Change 5700 millimetres to metres.

- (A) 0.57 m (B) 5.7 m (C) 57 m (D) 570 m

14) If the circumference of a circle is 154 cm , find its radius.

- (A) $\frac{154}{\pi}\text{ cm}$ (B) $\frac{77}{\pi}\text{ cm}$ (C) $\frac{100}{7\pi}\text{ cm}$ (D) $\frac{154}{7\pi}\text{ cm}$

15) Find area

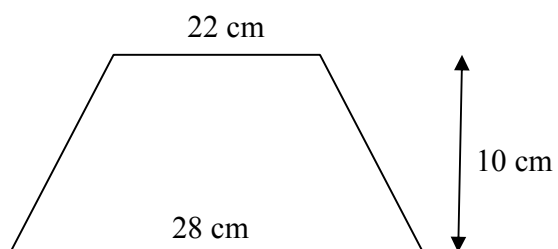

- (A) 500 cm^2 (B) 280 cm^2 (C) 250 cm^2 (D) 220 cm^2

16) The perimeter of the triangle is 150 cm. Find a .

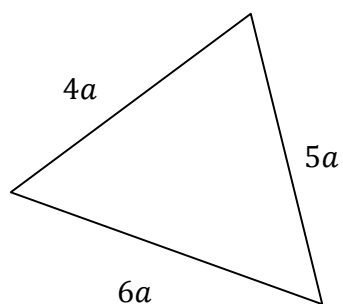

- (A) 10 cm (B) 15 cm (C) 20 cm (D) 12 cm

17) Find volume

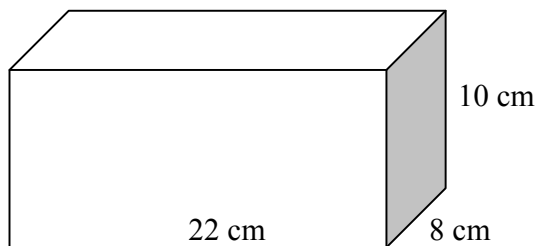

- (A) 40 cm^3 (B) 1760 cm^3 (C) 220 cm^3 (D) 80 cm^3

18) Find volume of the cube.

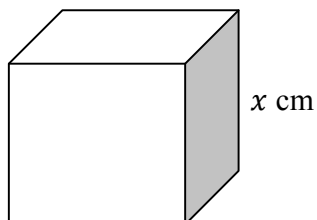

- (A) $3x \text{ cm}^3$ (B) $6x \text{ cm}^3$ (C) $36x \text{ cm}^3$ (D) $x^3 \text{ cm}^3$

19) 4900 millimeters to metres is

- (A) 49 m (B) 490 m (C) 4.9 m (D) 0.49 m

20) Find area

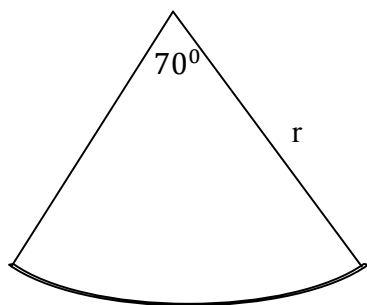

- (A) $\frac{7\pi r^2}{36}$ (B) $\frac{7\pi r^2}{360}$ (C) $70\pi r^2$ (D) $\frac{7\pi r^2}{36}$

21) The area of the trapezium is 28 cm^2 . Write an expression to represent this.

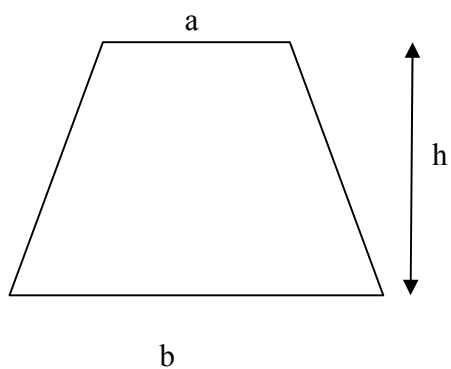

- (A) $28 = a \times h$ (B) $28 = \frac{(a \times h)}{2}$
 (C) $28 = (a + b) \times h$ (D) $28 = \frac{(a+b)}{2} \times \frac{h}{1}$

TEST 4

1) If the area of the triangle is 100 cm^2 , find h

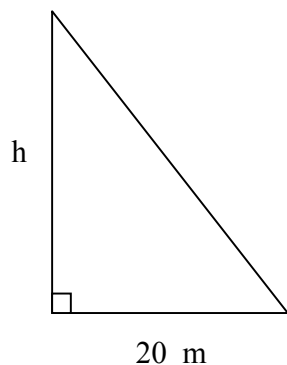

- (A) 10 cm (B) 15 cm (C) 20 cm (D) 25 cm

2)

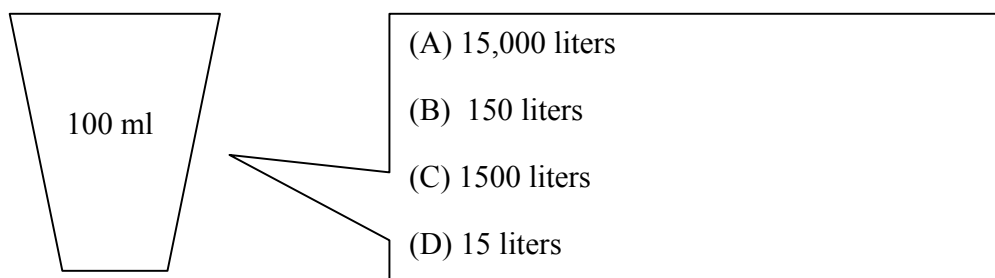

This glass can hold 100 ml of water. How many liters will 150 cups hold?

3)

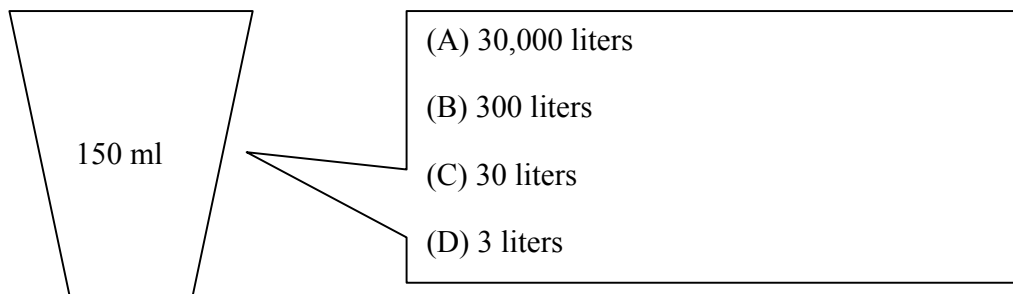

The mug can hold 150 ml of water. How many liters will 200 mugs hold?

4) Write an equation that can be used to find the value of x .

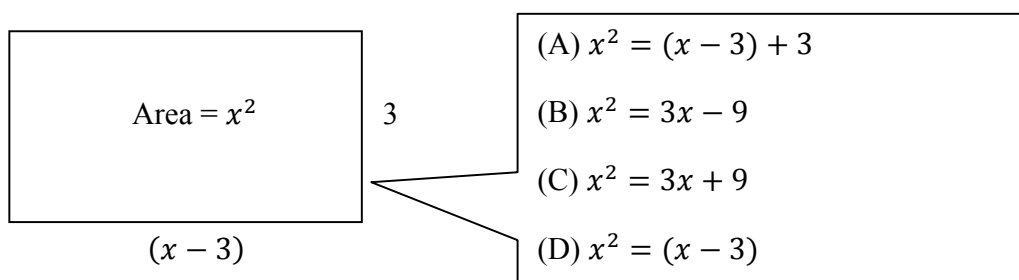

5) 80 marathon runners were given a cup of water. Each cup has a capacity of 200 ml. 50 runners took a second cup. How many liters of water did all the marathon runners drink that day?

- (A) 16 liters (B) 25 liters (C) 26 liters (D) 23 liters

6) The sizes of the interior angles of a polygon are x , $2x$, $3x$, 36° and 60° . Find the value of x

- (A) 74 (B) 70 (C) 75 (D) 80

7) If $1\text{ml} = 1\text{cm}^3$, how many liters of water would a container of volume 40 cm^3 hold?

- (A) 4 liters (B) 0.4 liters (C) 40 litres (D) 0.04 liters

8) Find the volume of the piece of wood.

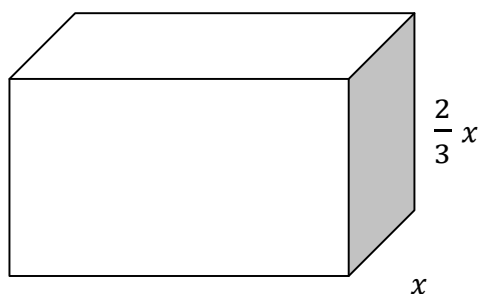

- (A) $\frac{16x^2}{9}$ (B) $\frac{16x^3}{9}$ (C) $\frac{16x}{9}$ (D) $16x^3$

9) What is the area of the shaded region?

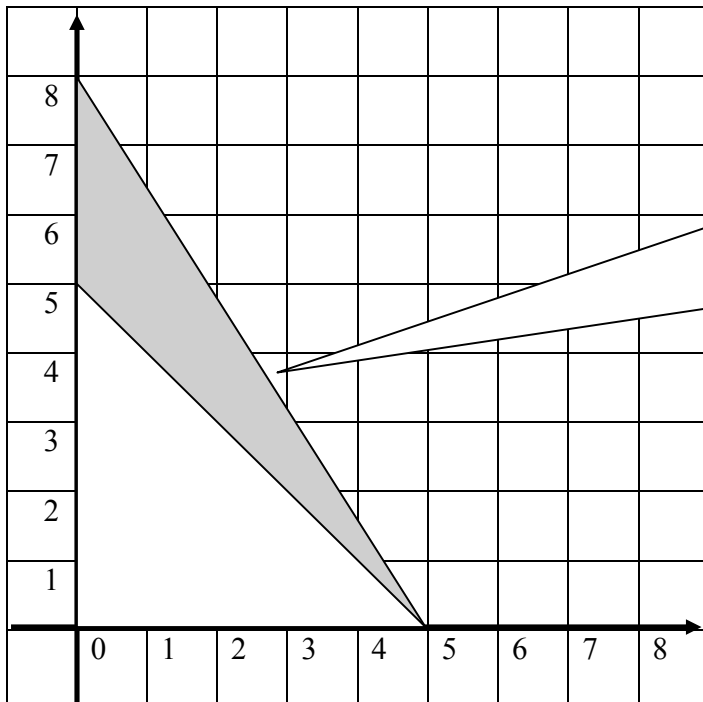

(A) 7.5 units^2

(B) 12.5 units^2

(C) 20 units^2

(D) 6.5 units^2

10) Find the area of the shape.

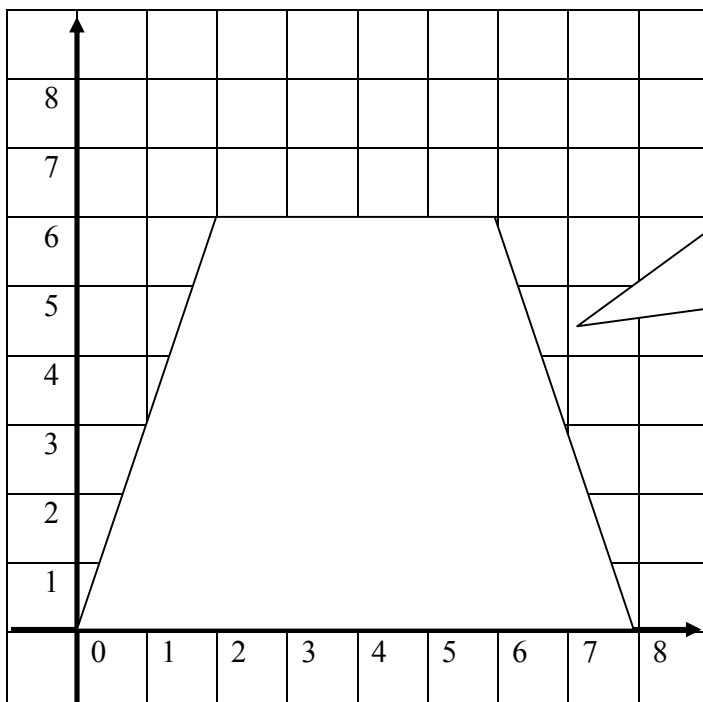

(A) 48 units^2

(B) 24 units^2

(C) 36 units^2

(D) 42 units^2

11) Find the area of the shaded portion.

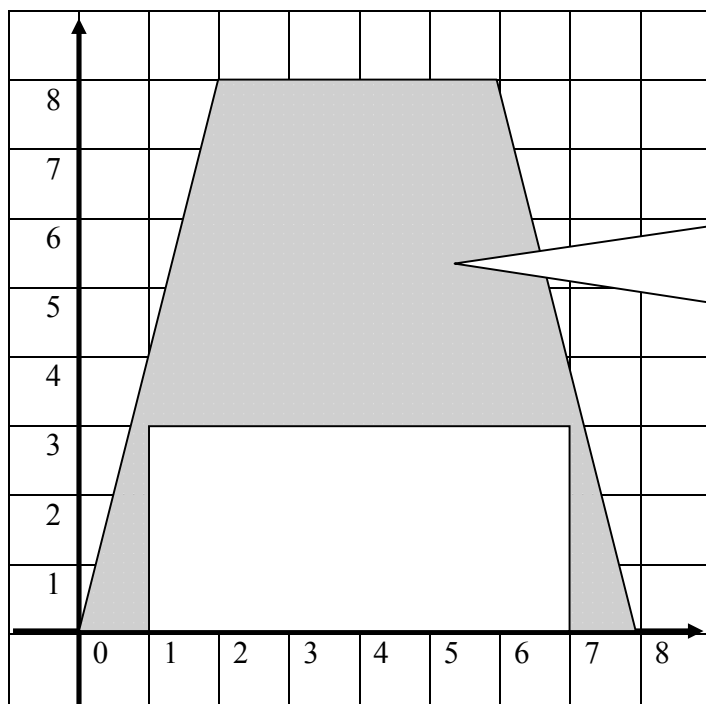

(A) 48 units^2

(B) 18 units^2

(C) 30 units^2

(D) 66 units^2

12) The area of the trapezium is 32 cm^2 . What is the value of x ?

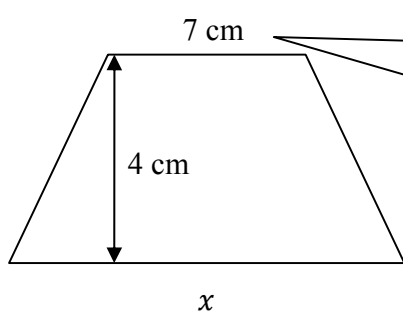

(A) 9 cm

(B) 8 cm

(C) 6 cm

(D) 4 cm

13) Which shape is a rectangular cuboid?

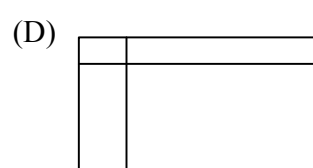
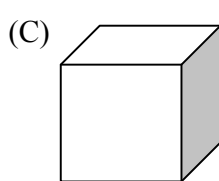
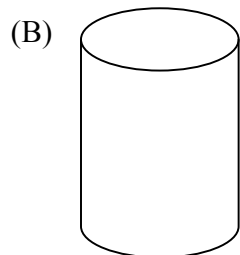
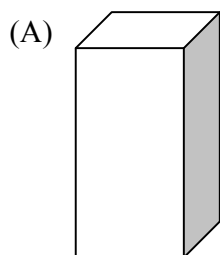

14) Find the area of the shaded part.

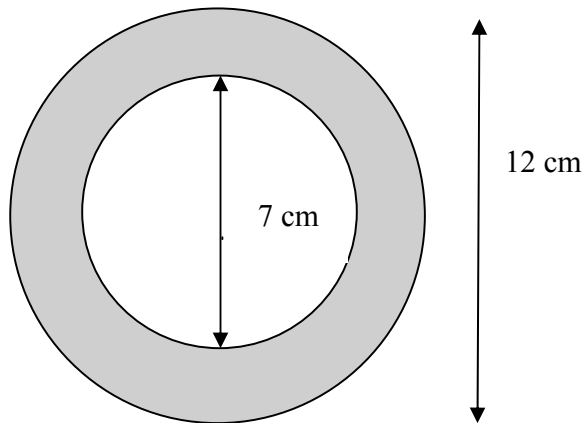

(A) 36π

(B) 12.25π

(C) 23.75π

(D) 48.75π

15) Find the area of the shaded portion.

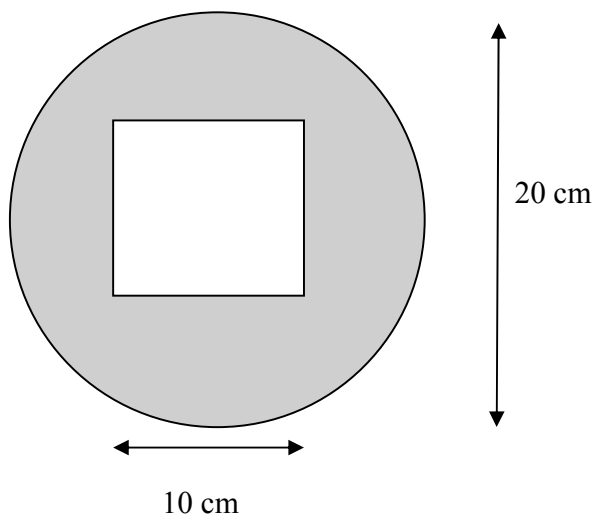

(A) $20\pi - 10\pi$

(B) $20\pi + 10\pi$

(C) $400\pi - 100\pi$

(D) $100(\pi - 1)$

16) Find the total area of the shaded parts.

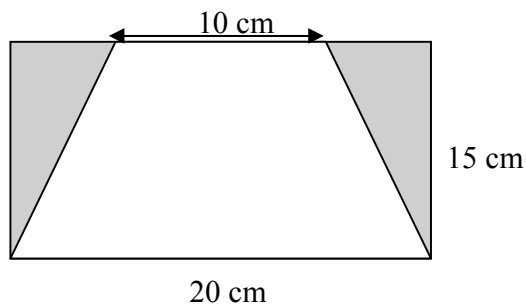

(A) 300 cm^2

(B) 75 cm^2

(C) 225 cm^2

(D) 85 cm^2

17) Change 2900 mm to metres.

(A) 2.9 m

(B) 29 m

(C) 290 m

(D) 0.29 m

18) Change 7650 kg to tonnes.

(A) 76 t

(B) 760 t

(C) 7.65 t

(D) 0.765 t

19) Change 1456 ml to litres.

(A) 14.56 litres

(B) 1.456 litres

(C) 145.6 litres

(D) 1456 litres

20) 2 litres of malt is to be shared equally among some guests at a party. Each glass can hold 125 ml. How many glasses can be filled with the malt?

(A) 12.5

(B) 10

(C) 20

(D) 16

6 Statistics

TEST 1

1) 0, 0, 1, 2, 2, 6, 7, 7, 7, 8, 10. Which number is the median?

- (A) 6 (B) 7 (C) 8 (D) 2

2) The heights of 5 tomato plants are 40 cm, 42 cm, 50 cm, 53 cm and 71 cm. Find the range.

- (A) 51.2 cm (B) 50 cm (C) 71 cm (D) 31 cm

3) What is the modal mark?

Marks	1	2	3	7	8	9
Number of students	2	3	12	2	4	2

- (A) 9 (B) 3 (C) 7 (D) 2

4) Find the range of the marks.

Marks	50	55	62	70	71	75
Number of students	2	3	12	2	4	2

- (A) 50 (B) 75 (C) 25 (D) 70

5) 100,000 students wrote an examination in the Caribbean region. It is expected that 30% of these students would pass. How many failed?

- (A) 70,000 (B) 30,000 (C) 20,000 (D) 40,000

6) How many people were tested positive for Covid 19 for the five days?

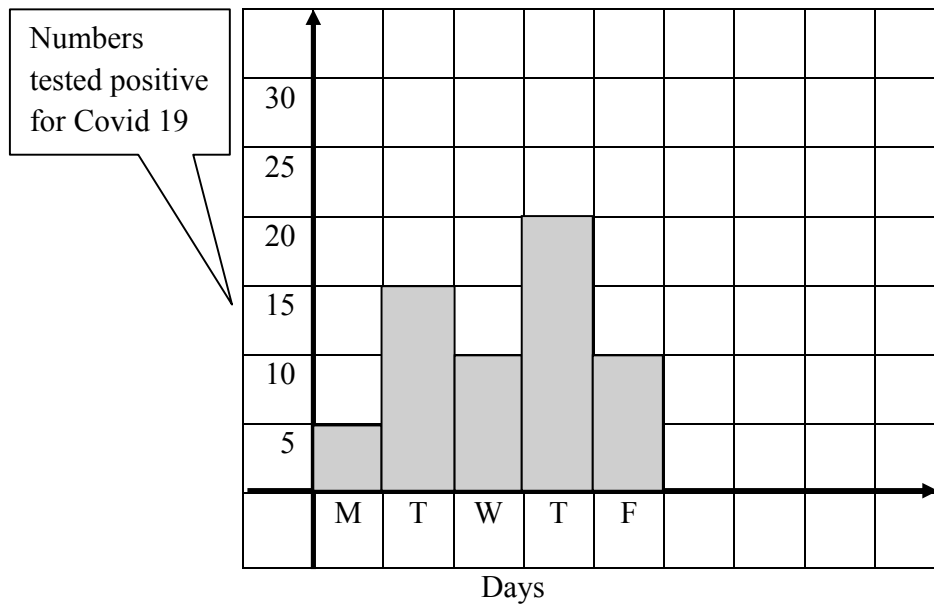

(A) 50

(B) 55

(C) 62

(D) 60

7) What is the modal score?

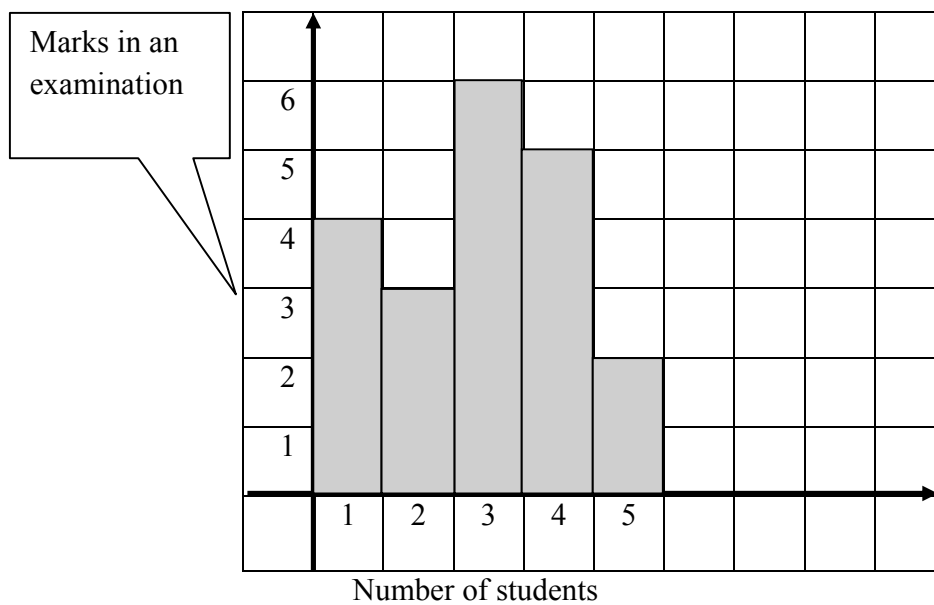

(A) 5

(B) 2

(C) 6

(D) 4

8) Out of 20,000 students who took an examination in July of this year, only 6000 are expected to pass. What is the probability that a student will fail?

- (A) $\frac{7}{10}$ (B) $\frac{3}{10}$ (C) $\frac{7}{20}$ (D) $\frac{3}{20}$

9) What is the median score: 0, 1, 4, 7, 7, 8, 8, 8, 10

- (A) 10 (B) 5.9 (C) 8 (D) 7

10) Two coins are tossed and the results are as follows: HH, TT, HT. What is the probability of getting two heads at once?

- (A) $\frac{2}{3}$ (B) $\frac{1}{4}$ (C) $\frac{1}{3}$ (D) $\frac{1}{6}$

11) Kenya scored the following number of goals in eight football matches: 5, 6, 6, 3, 2, 3, 1, 2. What is the median score?

- (A) 1 (B) 3 (C) 2 (D) 6

12) In a Statistics examination, the scores for 50 students are indicated in the table.

Marks	45	51	60	70	71	73
Number of students	10	7	4	20	3	6

What is the range mark?

- (A) 28 (B) 73 (C) 60 (D) 45

13)

UWI Open Campus Survey

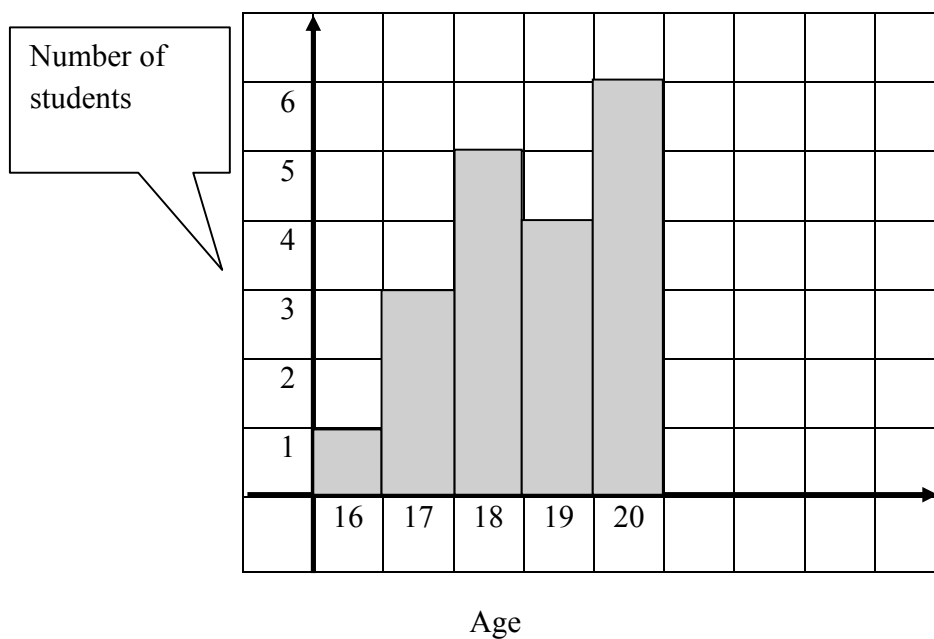

How many students were surveyed?

- (A) 20 (B) 16 (C) 19 (D) 20

14) What is the modal age in number 13 above?

- (A) 16 (B) 20 (C) 18 (D) 19

15) A box has 7 red, 5 blue and 3 black pens. A pen is taken out of the box in a random manner. What is the probability of getting a red pen?

- (A) $\frac{7}{15}$ (B) $\frac{5}{15}$ (C) $\frac{3}{15}$ (D) $\frac{8}{15}$

16) I throw a die. What is the probability of getting an even number?

- (A) $\frac{3}{4}$ (B) $\frac{1}{2}$ (C) $\frac{1}{6}$ (D) $\frac{5}{6}$

17) A student is chosen at random to run an errand to the Principal's office. What is the probability of choosing a footballer?

Sports	Number of students
Cricket	12
Football	20
Swimming	10
Sailing	8

- (A) $\frac{1}{2}$ (B) $\frac{2}{3}$
 (C) $\frac{2}{5}$ (D) $\frac{1}{3}$

18) What is the probability that a blue car was spotted that morning on the highway?

Colour of cars	Number of cars
Blue	20
Red	30
White	22
Black	28

- (A) $\frac{1}{2}$ (B) $\frac{2}{3}$
 (C) $\frac{2}{5}$ (D) $\frac{1}{5}$

19) State the median: 0, 0, 1, 1, 1, 2, 2, 3, 5, 7, 7, 10

- (A) 2 (B) 0 (C) 1 (D) 7

20) A Teacher's box has 4 red, 10 white and 3 blue sticks of chalk. What is the probability of randomly taking out a white stick of chalk from the box?

- (A) $\frac{4}{17}$ (B) $\frac{10}{17}$ (C) $\frac{3}{17}$ (D) $\frac{1}{17}$

TEST 2

1) 200 students wrote Introduction to Sociology examination at UWI last semester. How many students are predicted to fail if the pass rate is $\frac{3}{5}$?

- (A) 120 (B) 100 (C) 110 (D) 80

2) What is the probability of choosing a letter S from the word PHYSICS?

- (A) $\frac{1}{7}$ (B) $\frac{3}{7}$ (C) $\frac{2}{7}$ (D) $\frac{2}{5}$

3) What is the probability of choosing a letter M from the word MATHEMATICS?

- (A) $\frac{2}{11}$ (B) $\frac{1}{11}$ (C) $\frac{3}{11}$ (D) $\frac{4}{11}$

4) A die was tossed 10 times and the results shown on the table. What is the modal number shown by the die?

Die number	1	2	3	4	5	6
Number of times	1	2	1	3	1	2

(A) 3 (B) 4

(C) 3 (D) 1

5) A die was thrown 10 times and the results indicated: 6, 4, 2, 5, 1, 3, 4, 3, 6, 3. What is the modal score?

- (A) 1 (B) 2 (C) 6 (D) 3

6) In a class of 25 students, 10 had done their home work in Mathematics. What is the probability that a student did not do this home work?

- (A) $\frac{2}{5}$ (B) $\frac{1}{5}$ (C) $\frac{3}{5}$ (D) $\frac{2}{15}$

7) What is the median number?

6, 4, 7, 5, 4, 7, 8, 9, 8

- (A) 7 (B) 8 (C) 9 (D) 4

8) Which is the “**most frequent**” in a distribution?

- (A) mean (B) median (C) mode (D) range

9) Which value is the median?

12, 10, 7, 3, 9, 6, 9, 2

- (A) 8 (B) 9 (C) 10 (D) 12

10) Out of a class of 30 students, 18 are girls. What is the probability that a student chosen at random is a boy?

- (A) $\frac{1}{5}$ (B) $\frac{3}{5}$ (C) $\frac{4}{5}$ (D) $\frac{2}{5}$

11) Find the average of 12, 24, 20, 18 and 25.

- (A) 20 (B) 19.8 (C) 13 (D) 21

12) How many students had 1 pen?

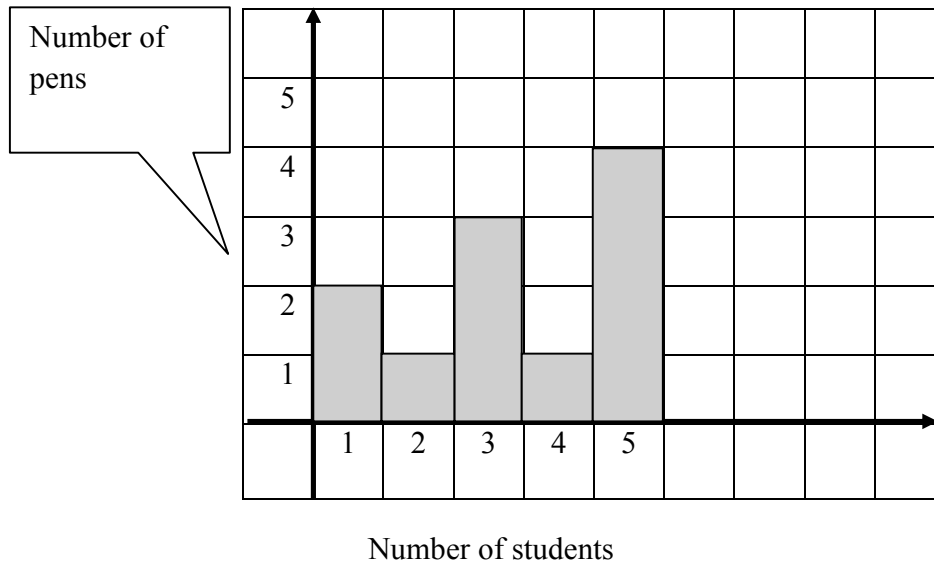

(A) 4

(B) 1

(C) 6

(D) 2

13) How many students have the most number of books?

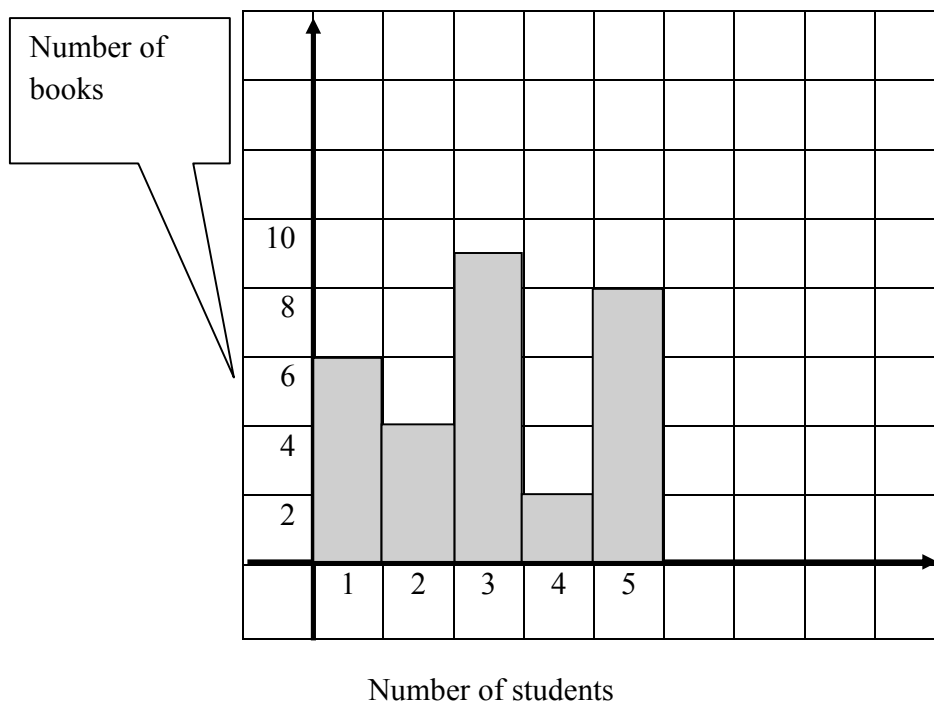

(A) 3

(B) 9

(C) 8

(D) 5

16) 900 students were surveyed at a Secondary School. The pie chart indicates the sports they like. How many played volleyball?

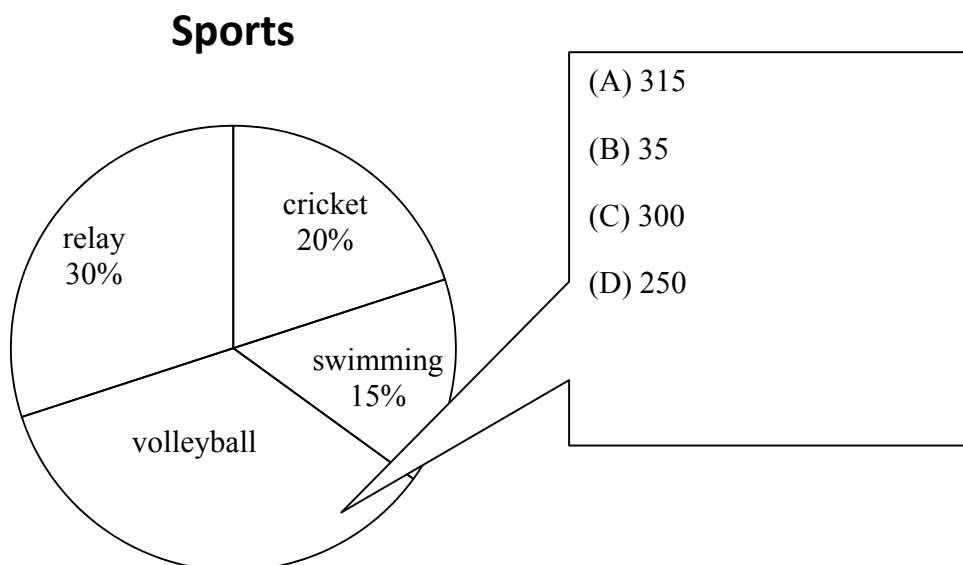

17) 200 students were surveyed and asked how they spent their Sundays. The results are shown on the pie chart. How many students spent their time reading?

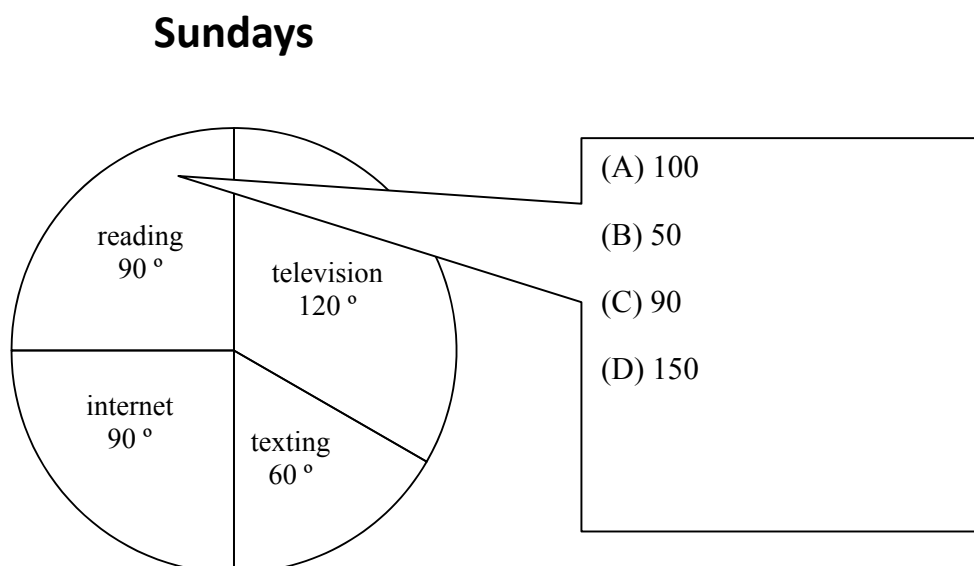

18) 20 students prefer tea. What is the total number of students represented by the pie chart?

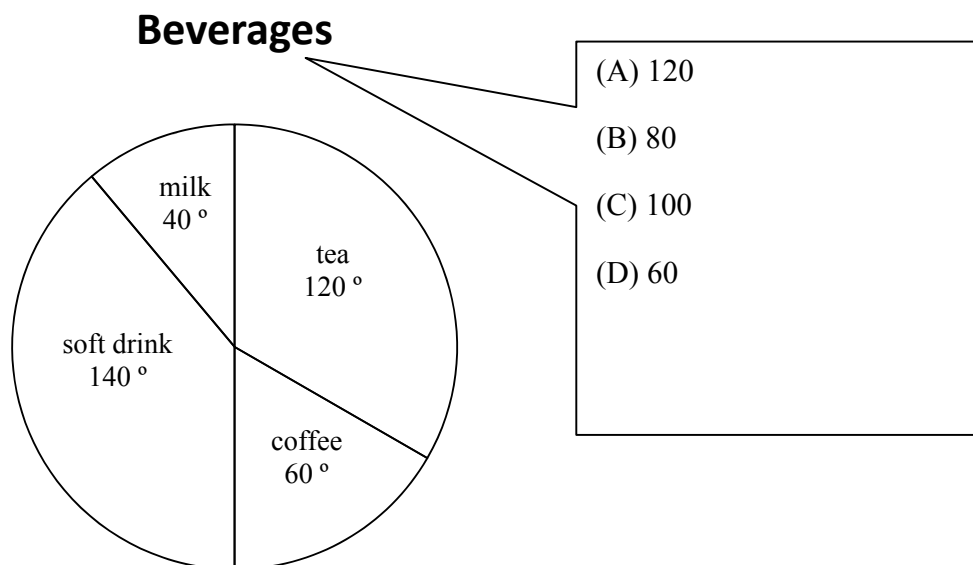

19) 120 students were surveyed about what sports they played. Their responses are given in the pie chart below. How many students played track and field?

Sports

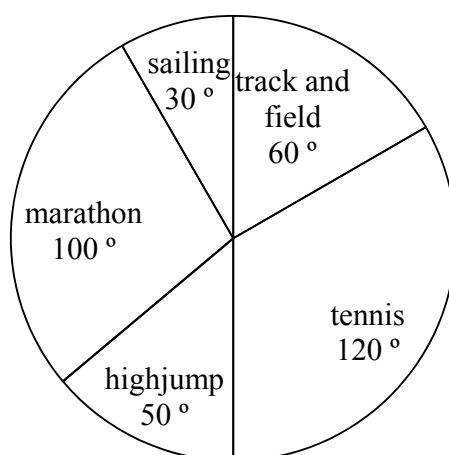

(A) 60

(B) 60

(C) 20

(D) 50

20) 60 students took part in a survey about their preferred beverage and the results shown on the pie chart. How many students like coffee?

Beverages

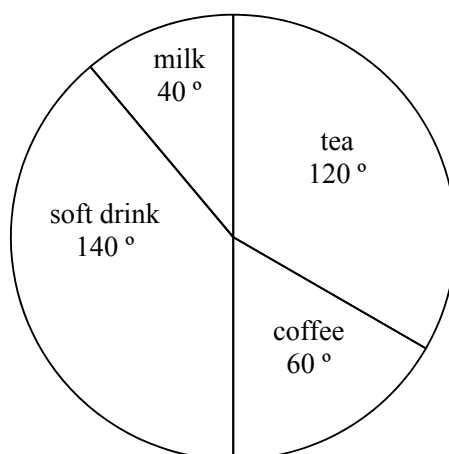

(A) 10

(B) 60

(C) 30

(D) 15

7 Relations functions and graphs

TEST 1

1) What are the x values where the curve $y = 6x - x^2$ intersect the line $y = 0$?

- (A) 1 and 2 (B) 0 and 6 (C) 3 and 4 (D) 5 and 6

2) Which coordinates represent the maximum point of the curve?

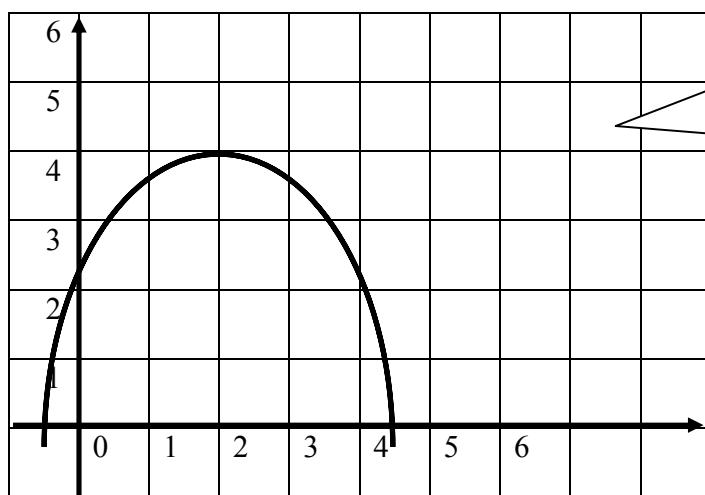

- (A) (2, 4)
 (B) (4, 2)
 (C) (4.5, 0)
 (D) (1, 4)

3) Which coordinates represent the minimum point of the curve?

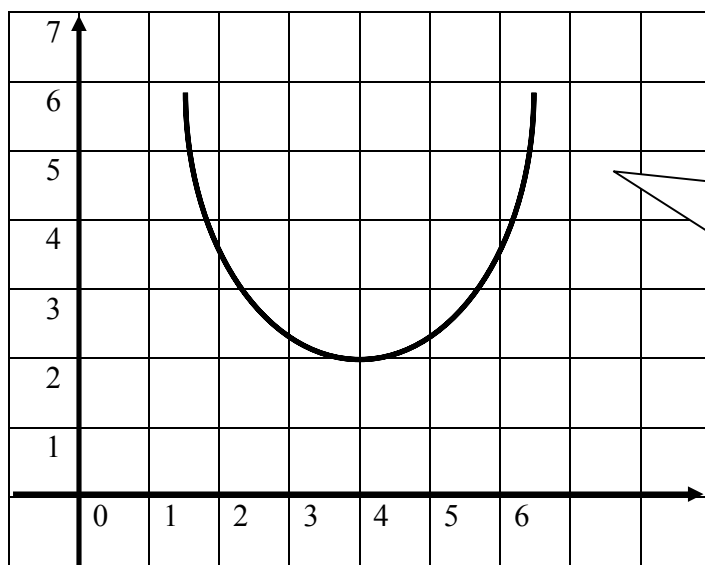

- (A) (2, 4)
 (B) (4, 2)
 (C) (6.5, 6)
 (D) (1, 6)

4) Where does the line intersect the x-axis?

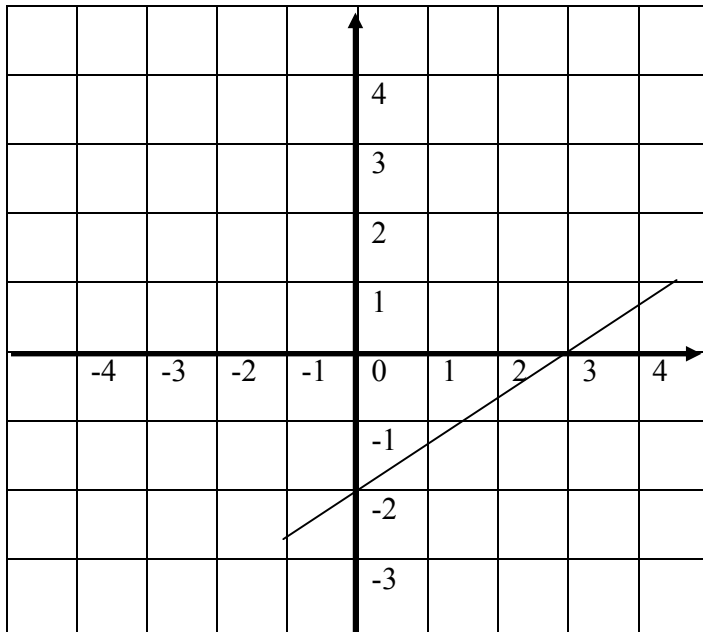

- (A) $(0, 3)$ (B) $(0, -2)$ (C) $(-2, 0)$ (D) $(3, 0)$

5) Where does the line intersect the y-axis?

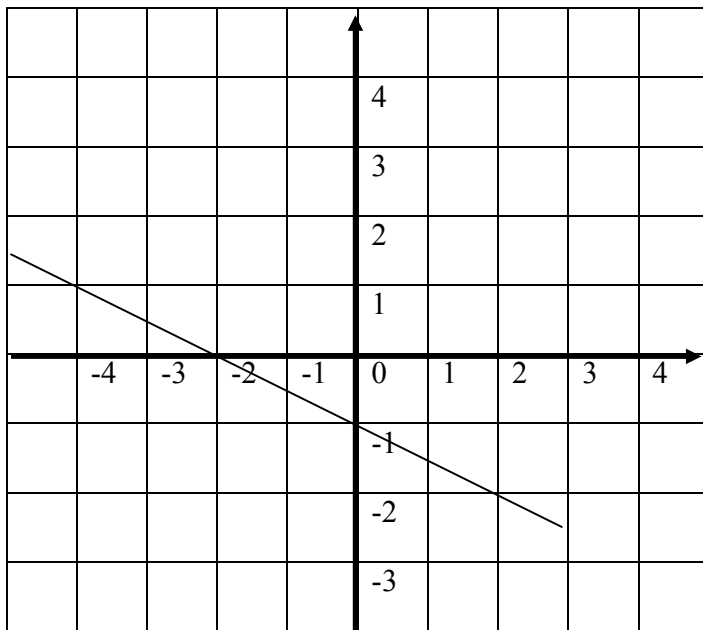

- (A) $(-1, 0)$ (B) $(-2, 0)$ (C) $(0, -1)$ (D) $(0, -2)$

6) What are the x values where the curve cuts the x-axis?

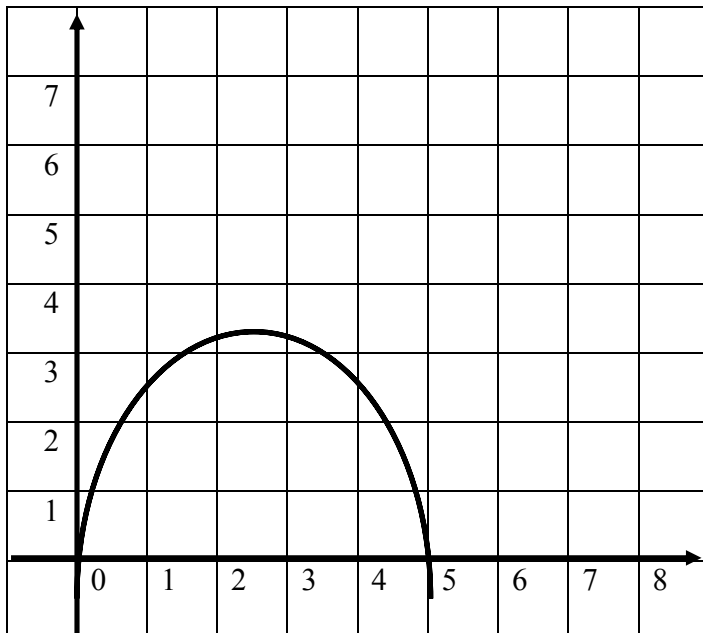

- (A) 0 and 5 (B) 5 and 5 (C) 0 and 0 (D) 1 and 5

7) What are the y values where the curve cuts the x-axis?

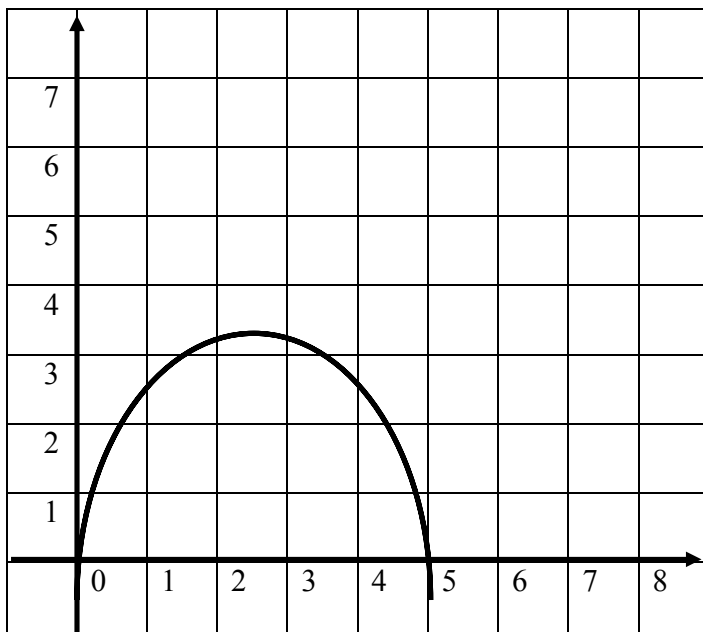

- (A) 0 and 5 (B) 1 and 0 (C) 1 and 5 (D) 0 and 0

8) Write an equation for the line which has gradient $\frac{2}{3}$ and passes through the point (1, 2)

(A) $y = \frac{1}{3}x + 1\frac{1}{3}$

(B) $y = \frac{2}{3}x + \frac{1}{3}$

(C) $y = \frac{2}{3}x + 1\frac{1}{3}$

(D) $y = \frac{2}{3}x + 1\frac{2}{3}$

9) Which point lies on the line $y = 3x - 2$?

(A) (0, 2)

(B) (1, 2)

(C) (2, 3)

(D) (3, 7)

10) Which equation is a straight line?

(A) $xy = 5$

(B) $y + 4 = 3x$

(C) $y - 2 = x^2$

(D) $y = x^2 - 3x + 2$

11) What is the gradient of $3y = x + 3$

(A) $\frac{1}{3}$

(B) $\frac{2}{3}$

(C) 1

(D) 3

12) Write an equation for the line that passes through the point (2, 3) and has a gradient of 3.

(A) $y = 2x + 3$

(B) $y = 3x + 2$

(C) $y = 3x - 3$

(D) $3y = 2x + 3$

13) The straight line cuts both axes at:

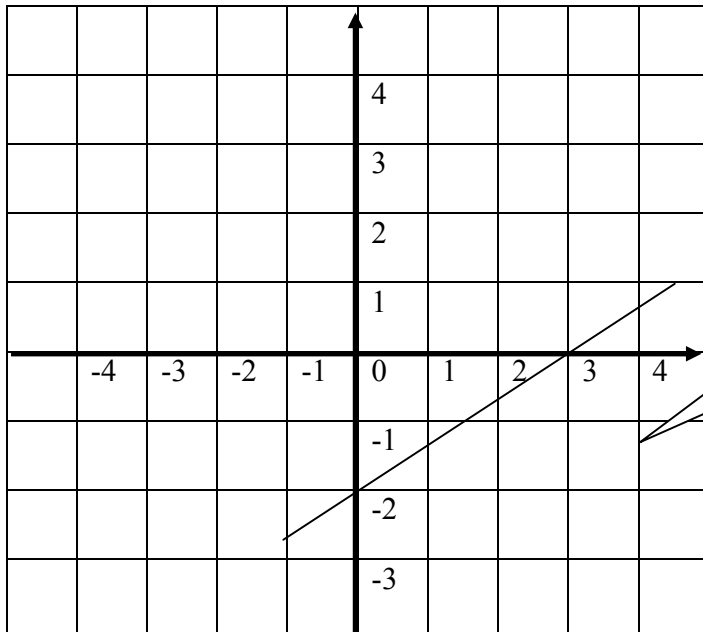

- (A) (0, 3) and -2, 0)
- (B) 3 and -2
- (C) -2 and 3
- (D) (3, 0) and (0, -2)

14) The straight line cuts both axes at:

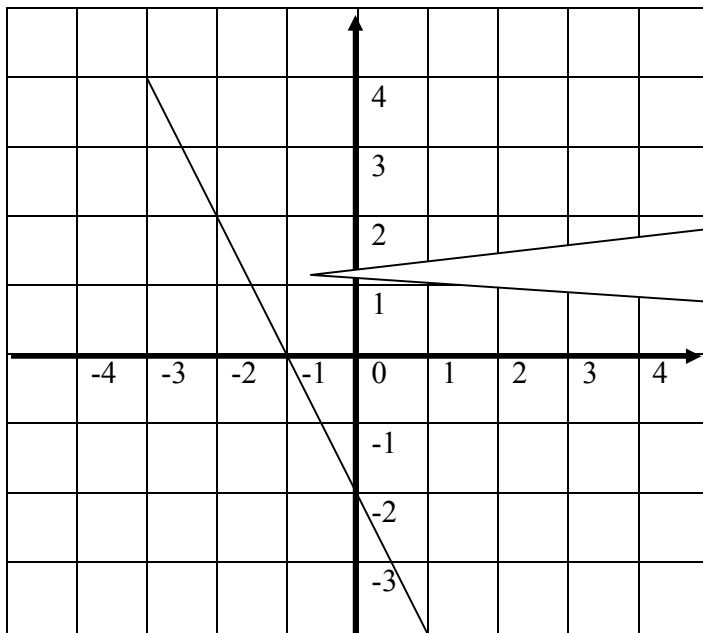

- (A) (0, -1) and (-2, 0)
- (B) (-1, 0) and (0, -2)
- (C) -1 and -2
- (D) -2 and -1

15) Find the gradient of the line.

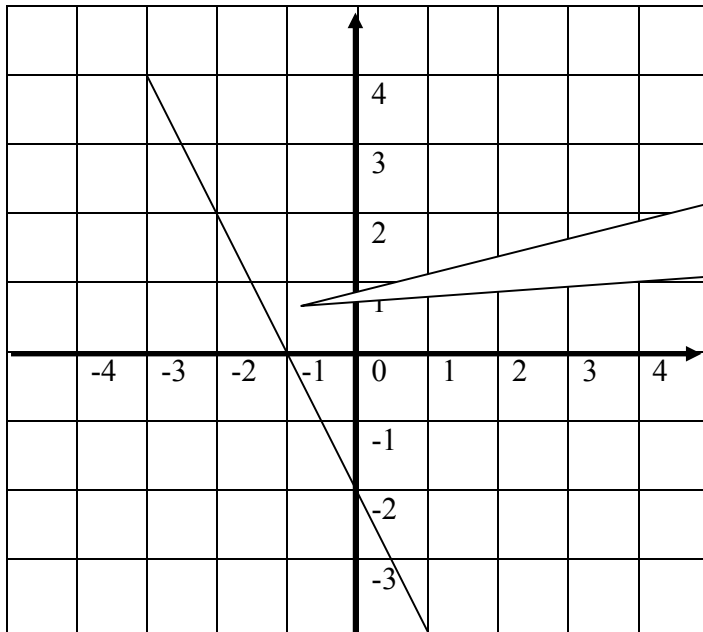

(A) -2

(B) 2

(C) 8

(D) 4

16) Find the gradient of the line.

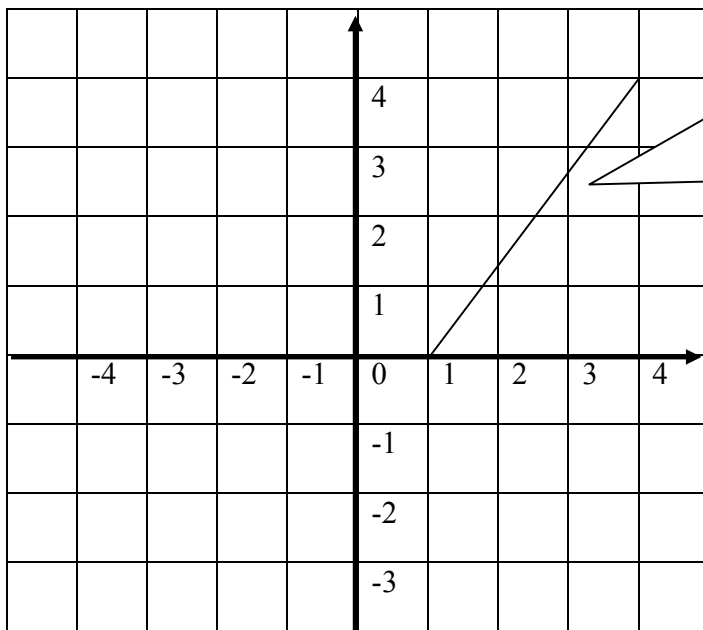

(A) $\frac{3}{4}$

(B) 4

(C) $\frac{4}{3}$

(D) 3

17) What is the gradient of the equation? $2y = -5x - 7$

- (A) -5 (B) $-\frac{2}{5}$ (C) 5 (D) $-\frac{5}{2}$

18) The line cuts the x-axis at

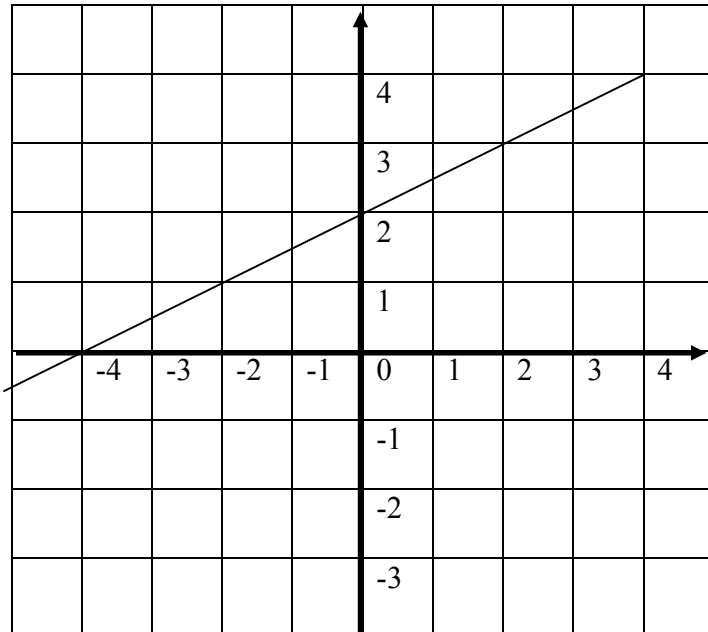

- (A) $(0, -4)$ (B) $(-4, 0)$ (C) $(0, 2)$ (D) $(2, 0)$

19) What is the maximum point?

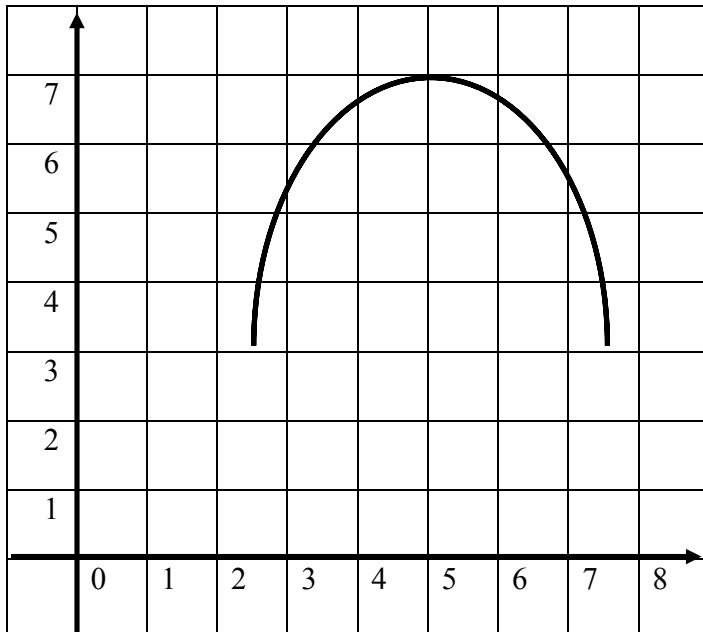

- (A) (5, 7) (B) (7, 5) (C) 7 (D) 5

20) What are the x values when $y = 5x - x^2$ and $y = 0$ intersect?

- (A) -1 and 5 (B) 1 and -5 (C) -1 and -5 (D) 0 and 5

TEST 2

1) Which one is not the equation of a straight line?

- (A) $x + y = 5$ (B) $y + 4 = 3x$ (C) $y - 2 = x$ (D) $y = x^2 - 3x + 2$

2) State the gradient of $3y - 4x = -9$

- (A) $\frac{4}{3}$ (B) $\frac{3}{4}$ (C) -4 (D) -9

3) The line cuts the x-axis at

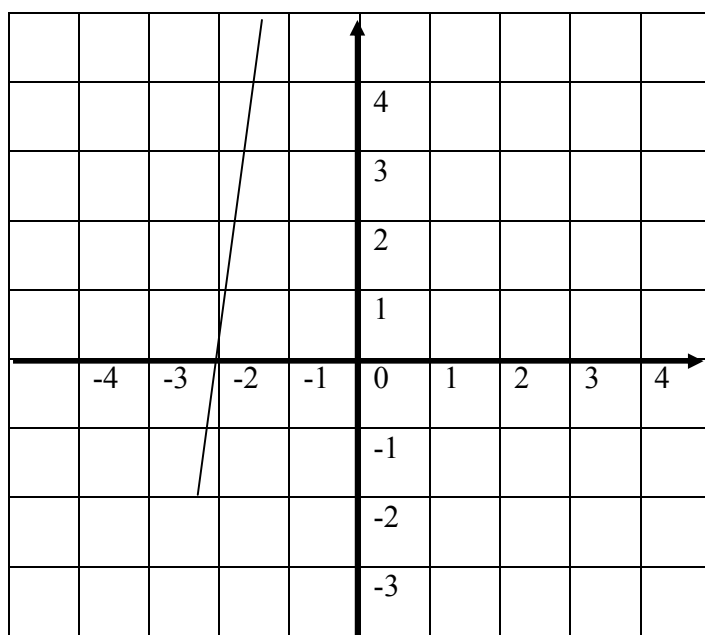

- (A) $(0, -2)$ (B) $(-2, 0)$ (C) Not shown (D) Does not cut

4) Which point lies on the line $y = 2x - 3$?

- (A) $(1, 0)$ (B) $(2, 3)$ (C) $(3, 4)$ (D) $(4, 5)$

5) The line cuts the y-axis at

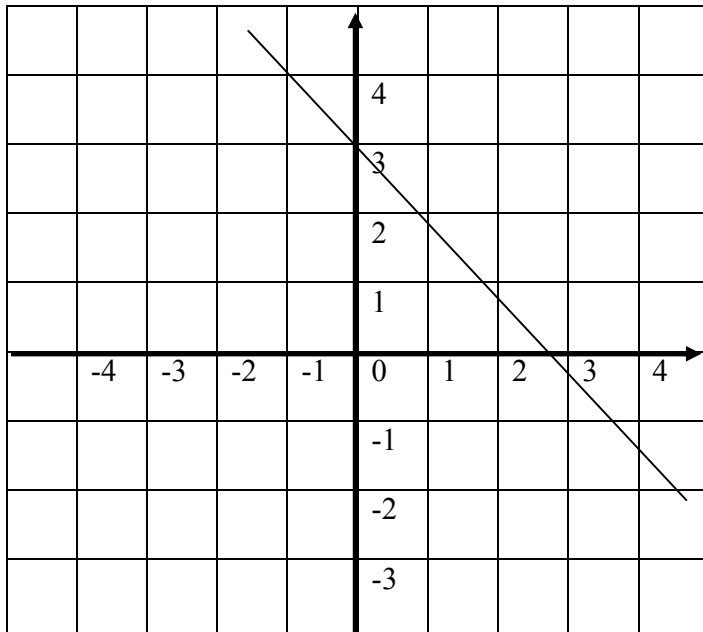

- (A) (3, 0) (B) (0, 0) (C) (0, 3) (D) (1, 2)

6) Which equation represents a straight line?

- (A) $x + y = 5$ (B) $y + 4 = 3x^2$ (C) $y - 2 = x^3$ (D) $y = x^2 - 3x + 2$

7) When $y = 4x - x^2$ and $y = 0$ intersect, what are the x-values?

- (A) 1 and 4 (B) -1 and 4 (C) 0 and -4 (D) 0 and 4

8) Write an equation for the line which has gradient $\frac{2}{3}$ and passes through the point (3, 4).

- (A) $4y = 3x + \frac{2}{3}$ (B) $3y = 4x + \frac{2}{3}$ (C) $y = \frac{2}{3}x + 2e$ (D) $y = mx + c$

9) Find the gradient of the line that passes through the points A(2, 4) and B(-6, -8).

- (A) $-\frac{3}{2}$ (B) $\frac{3}{2}$ (C) $\frac{2}{3}$ (D) $-\frac{2}{3}$

10) What is the gradient of a line that passes through the origin and a point M(6,12)?

- (A) 2 (B) -2 (C) 6 (D) 12

11) Which one is a straight line?

- (A) $4y = 3x^2 + \frac{2}{3}$ (B) $3y^2 = 4x + \frac{2}{3}$ (C) $y^2 = \frac{2}{3}x + 3$ (D) $y = mx + c$

12) What is the gradient of $3y = 2x - 8$?

- (A) $-\frac{3}{2}$ (B) $\frac{3}{2}$ (C) $\frac{2}{3}$ (D) $-\frac{2}{3}$

13) Which equation will give a curve?

- (A) $y = 3x + \frac{2}{3}$ (B) $y = 4x + \frac{2}{3}$ (C) $y^2 = \frac{2}{3}x + 2$ (D) $y = mx + c$

14) What is the name of the line AB that touches the curve?

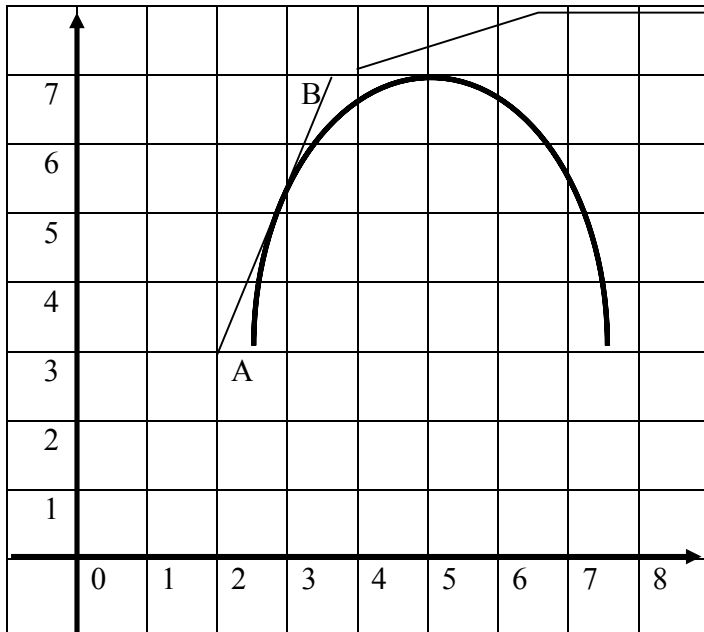

- (A) A chord
- (B) A tangent
- (C) A line segment
- (D) An angular line

15) What is the gradient of the line AB in question 14 above?

- (A) 2.7
- (B) -2.5
- (C) 4
- (D) 1.6

16) Find the gradient of the line MN.

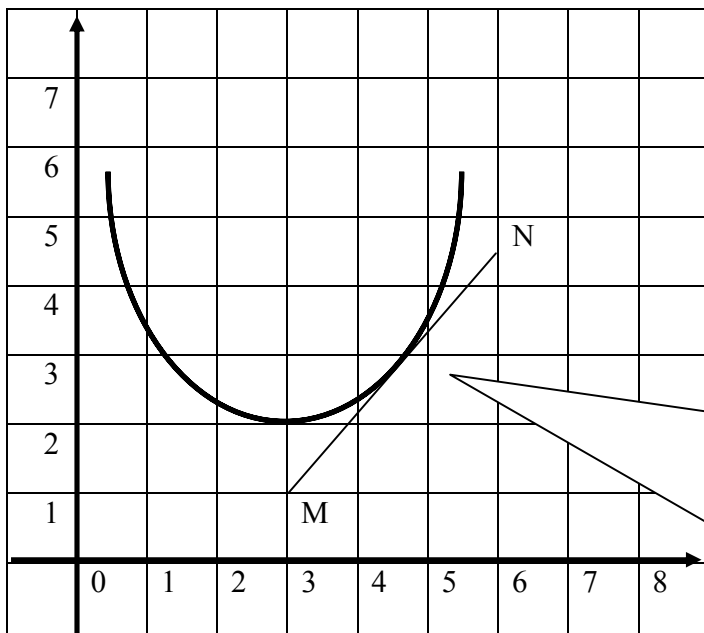

- (A) $\frac{4}{3}$
- (B) $\frac{4.5}{3}$
- (C) $-\frac{3.5}{3}$
- (D) $\frac{3.5}{3}$

17) Which formula will not give the gradient of a line?

(A) $\frac{\text{vertical height}}{\text{horizontyal distance}}$

(B) $\frac{\text{rise}}{\text{run}}$

(C) $a^2 + b^2 = c^2$

(D) $\frac{y_1 - y_2}{x_1 - x_2}$

18) Which formula will give the mid point of a line.

(A) $\left(\frac{x_1 + x_2}{2}, \frac{y_1 + y_2}{2} \right)$

(B) $\frac{y_1 - y_2}{x_1 - x_2}$

(C) $\frac{a + b}{2}$

(D) $\frac{x + y}{2}$

19) Find the midpoint of the line WX.

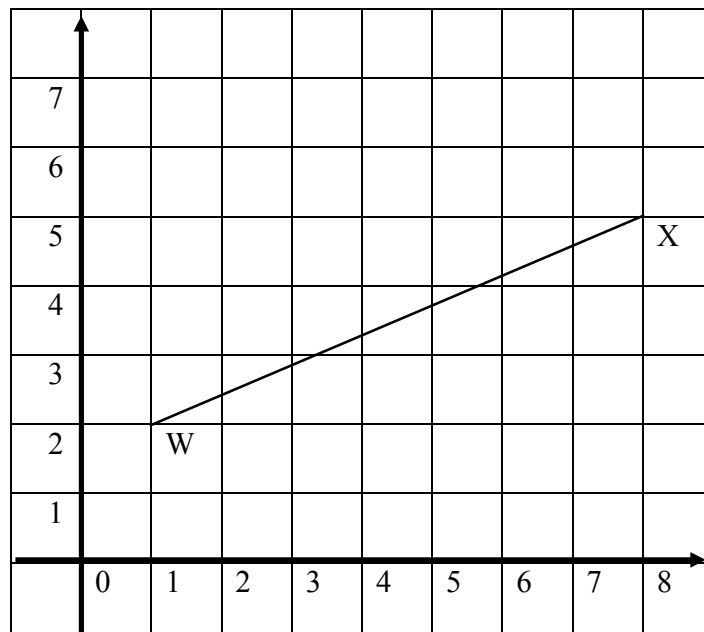

(A) (4, 3)

(B) (4.5, 3.5)

(C) (5, 3.5)

(D) (4, 5)

20) Find the length of the line.

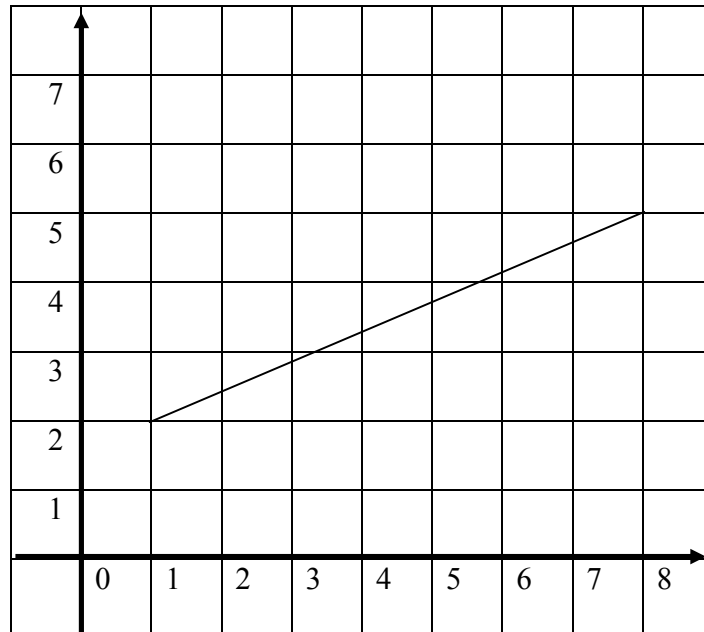

(A) $\sqrt{49}$

(B) $\sqrt{9}$

(C) $\sqrt{58}$

(D) $\sqrt{57}$

TEST 3

1) Write the equation of the 20 lines in this test.

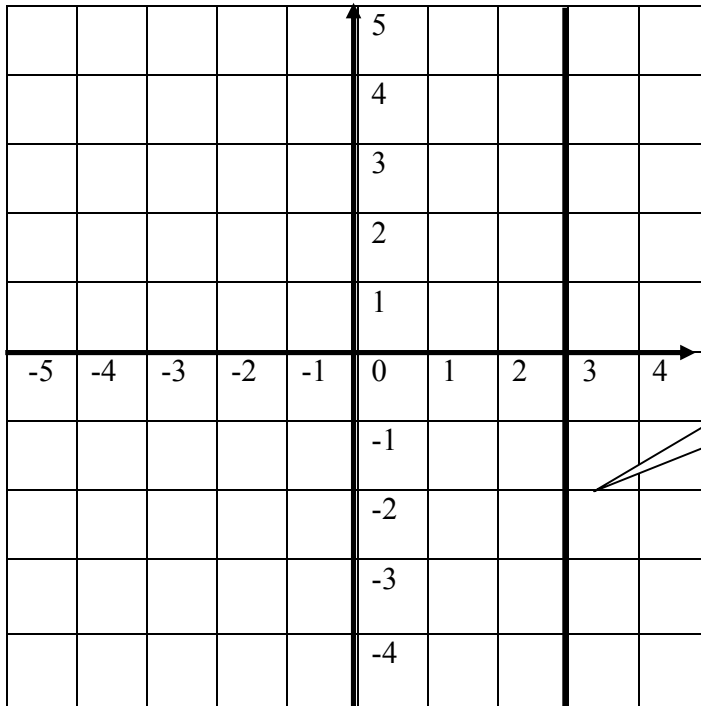

(A) $y = 3$

(B) $y = 2$

(C) $x = 3$

(D) $x = y$

2)

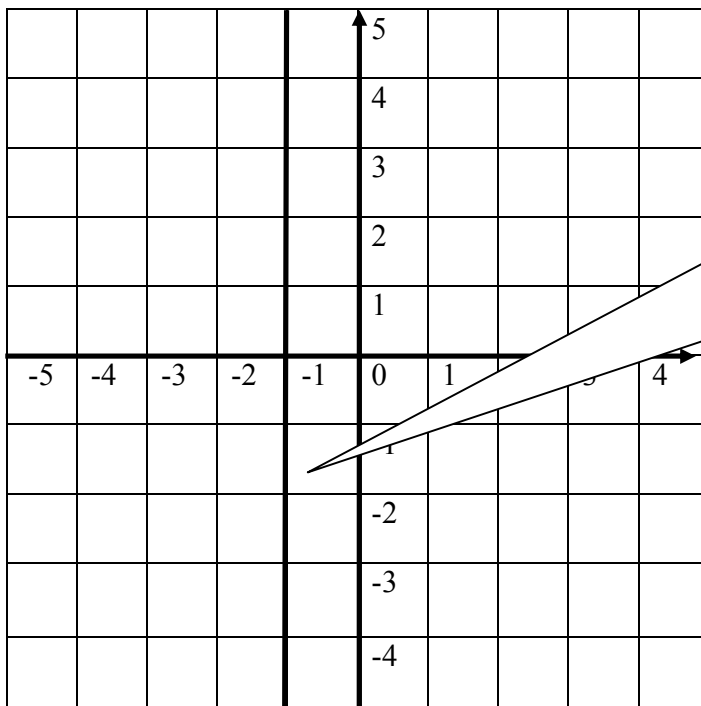

(A) $x = -1$

(B) $y = -1$

(C) $x = -2$

(D) $x = y$

3)

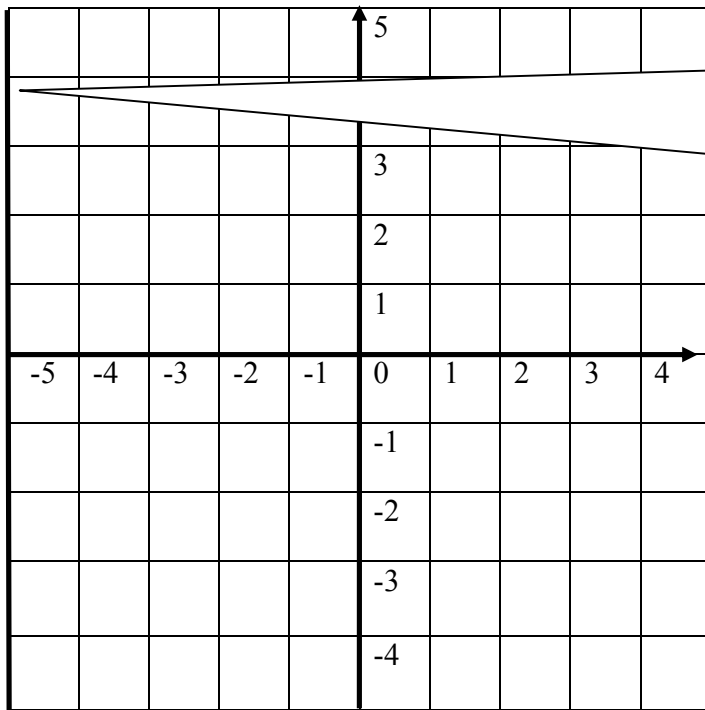

(A) $y = -5$

(B) $x = -5$

(C) $x = 3$

(D) $x = y$

4)

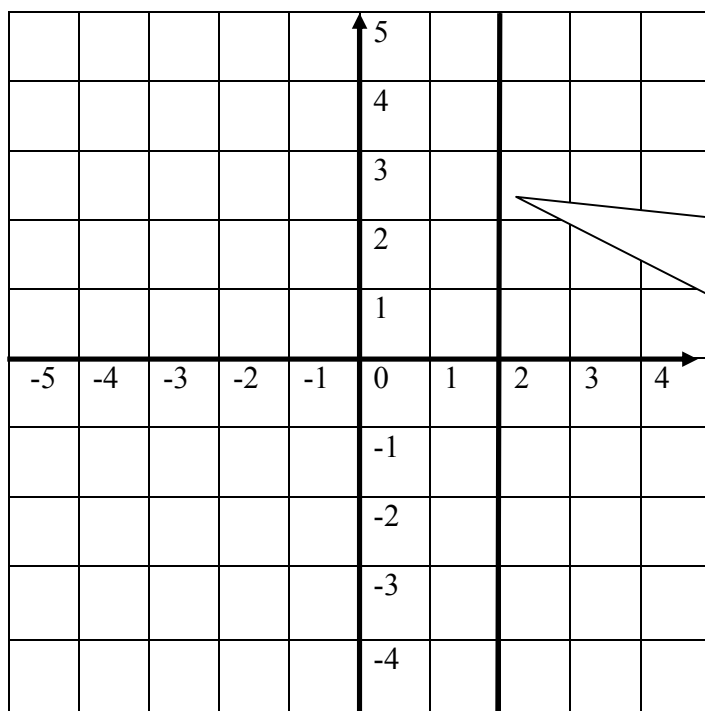

(A) $y = 3$

(B) $y = 2$

(C) $x = y$

(D) $x = 2$

5)

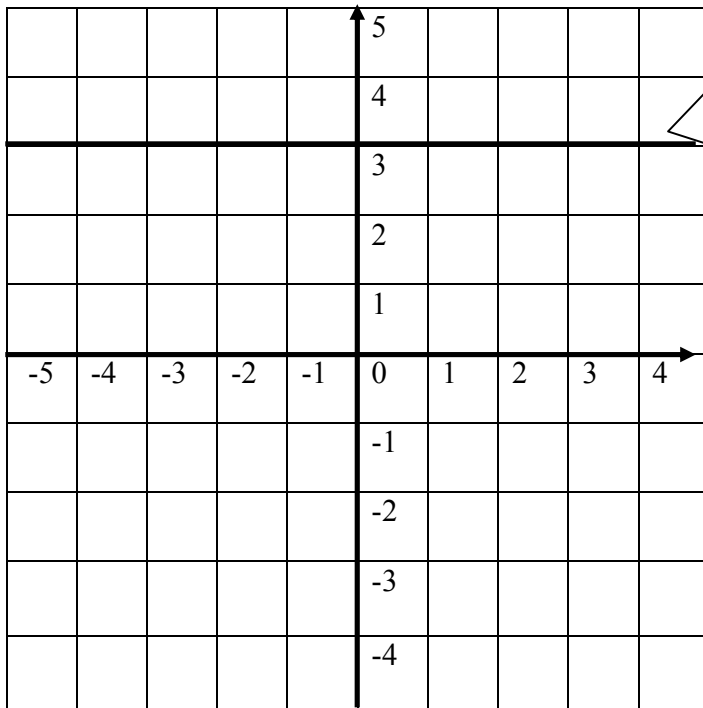

(A) $y = 3$

(B) $y = 2$

(C) $x = 3$

(D) $x = y$

6)

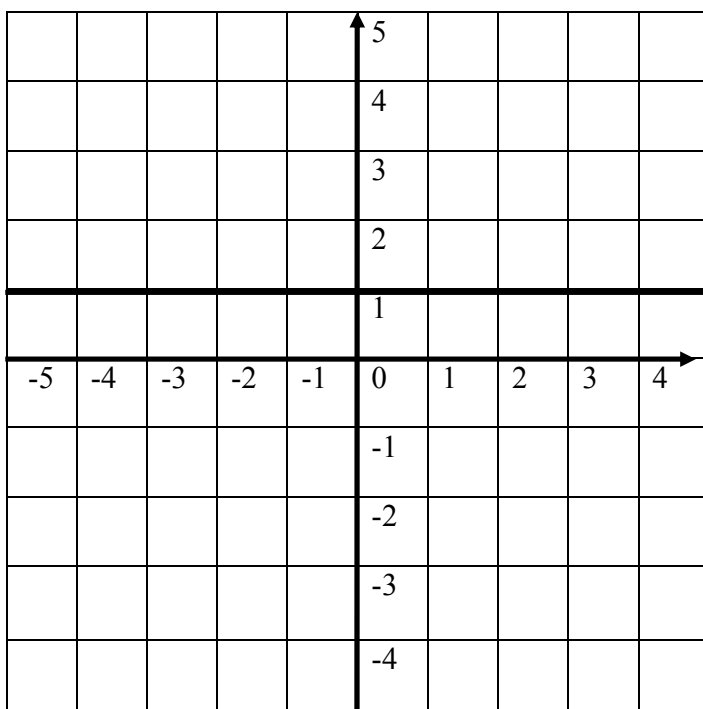

(A) $x = 1$

(B) $y = 2$

(C) $y = 1$

(D) $x = y$

7)

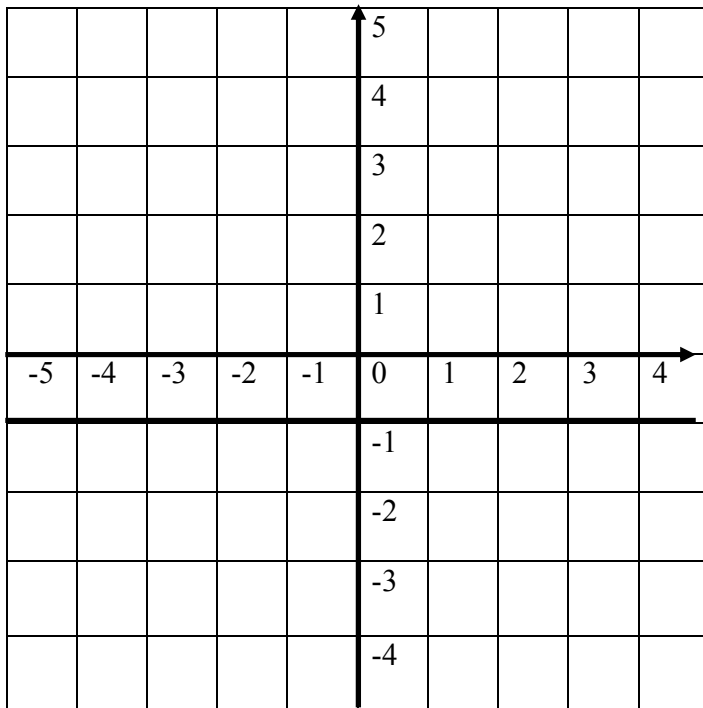

(A) $y = -1$

(B) $y = 2$

(C) $x = -1$

(D) $x = y$

8)

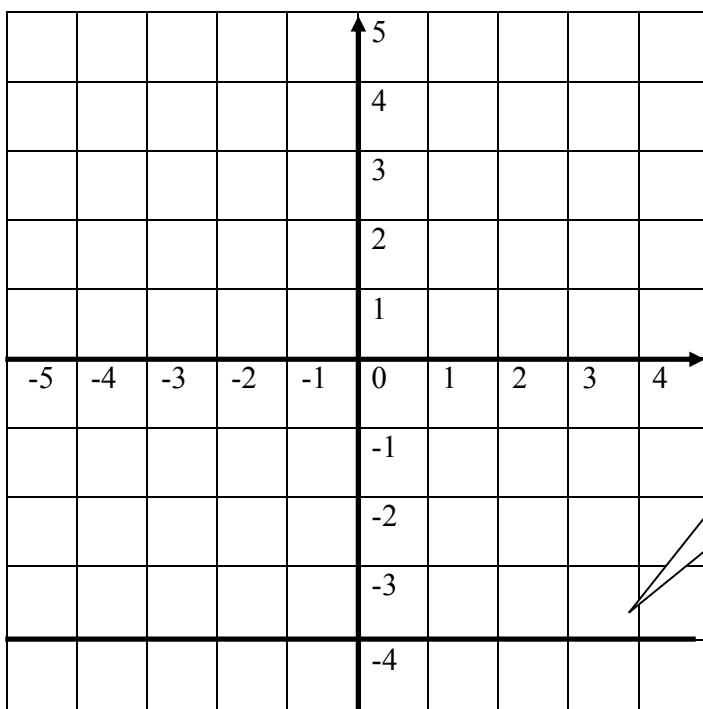

(A) $x = -4$

(B) $y = x$

(C) $x = 3$

(D) $y = -4$

9)

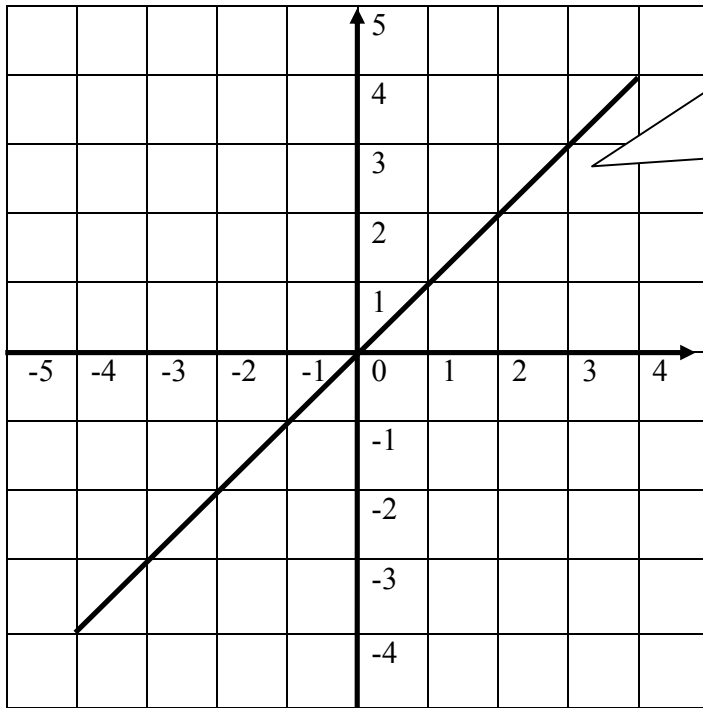

(A) $y = x$

(B) $y = 4$

(C) $x = -4$

(D) $2x = y$

10)

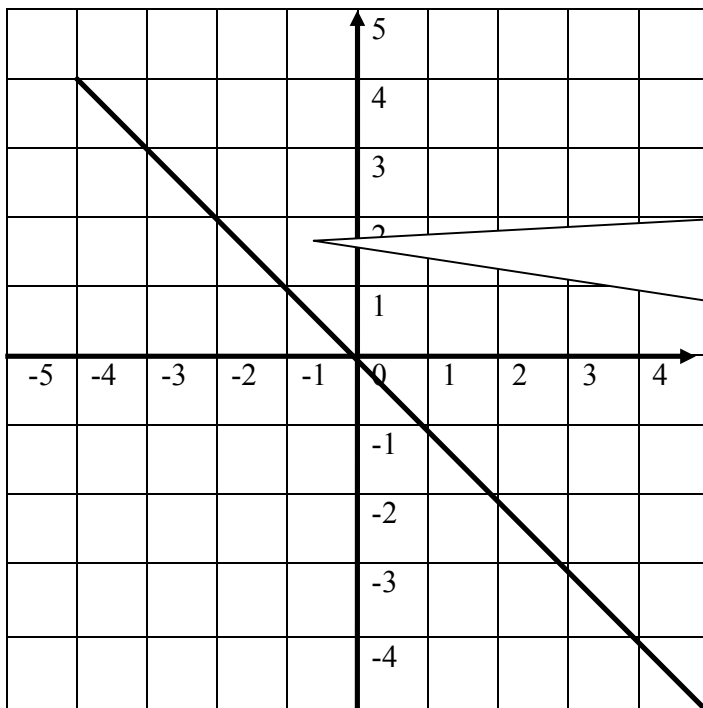

(A) $y = -x$

(B) $y = 4$

(C) $x = -4$

(D) $2x = y$

11)

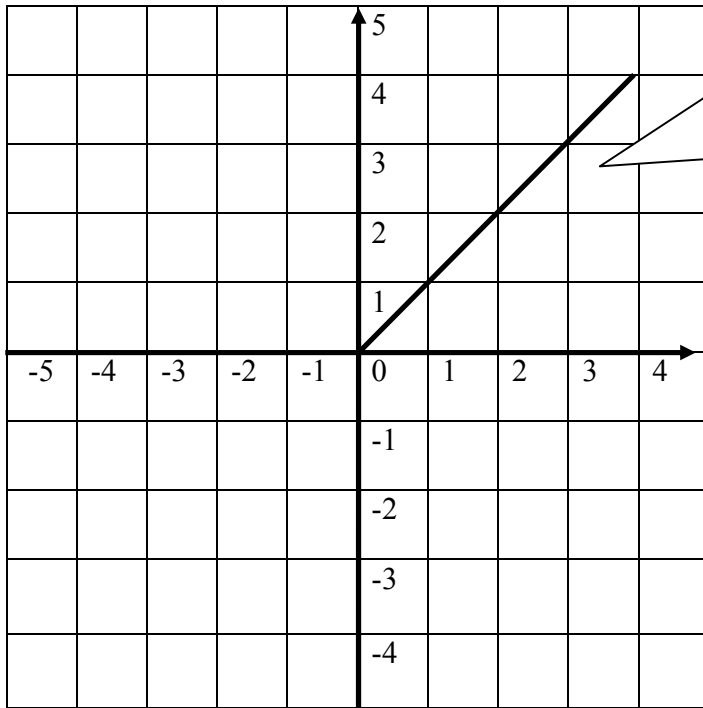

(A) $y = -x$

(B) $y = 0$

(C) $x = 4$

(D) $y = x$

12)

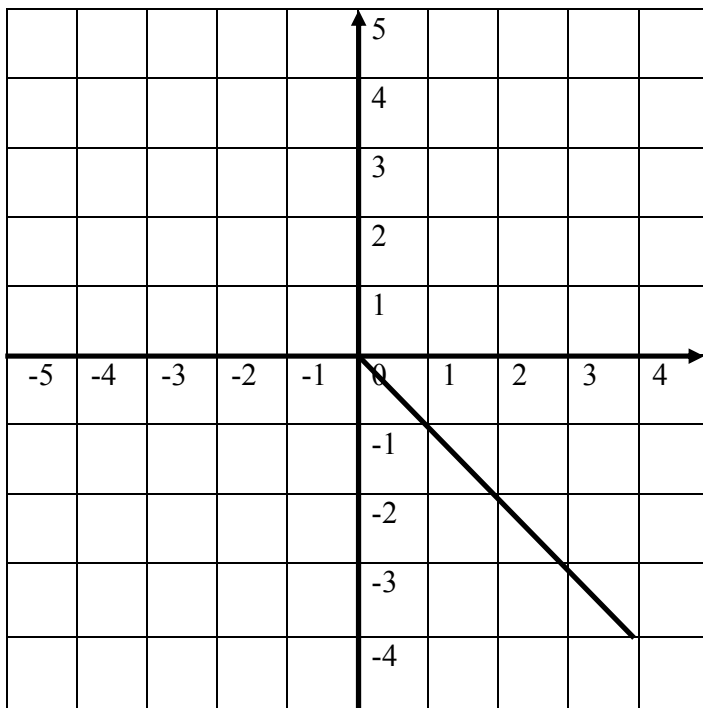

(A) $y = x$

(B) $y = 4$

(C) $y = -x$

(D) $2x = y$

13)

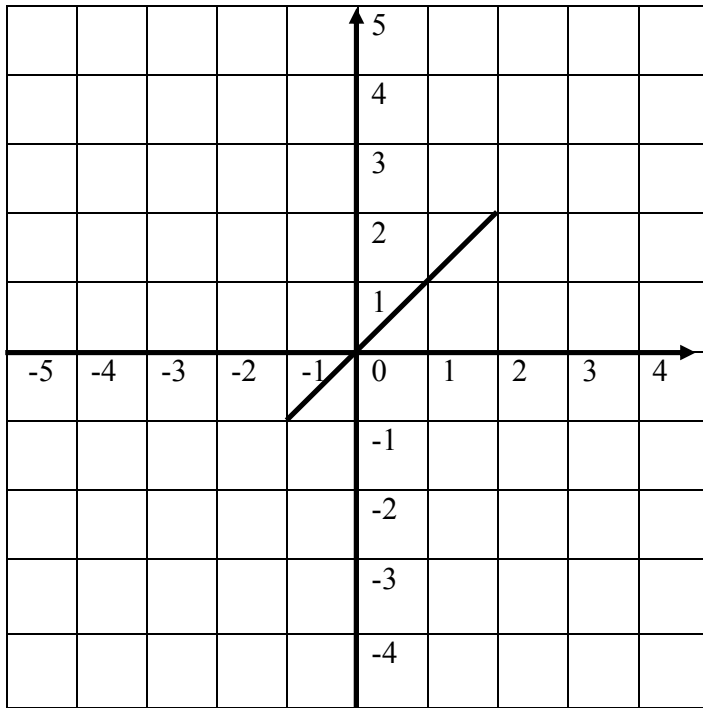

(A) $y = x$

(B) $y = 2$

(C) $y = -x$

(D) $2x = y$

14)

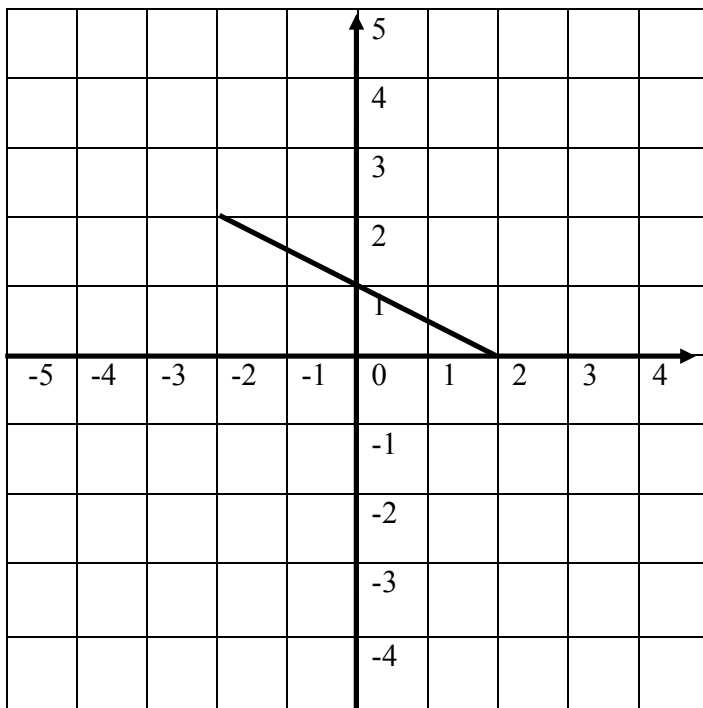

(A) $y = x$

(B) $y = -\frac{1}{2}x + 1$

(C) $y = -x$

(D) $2x = y$

15)

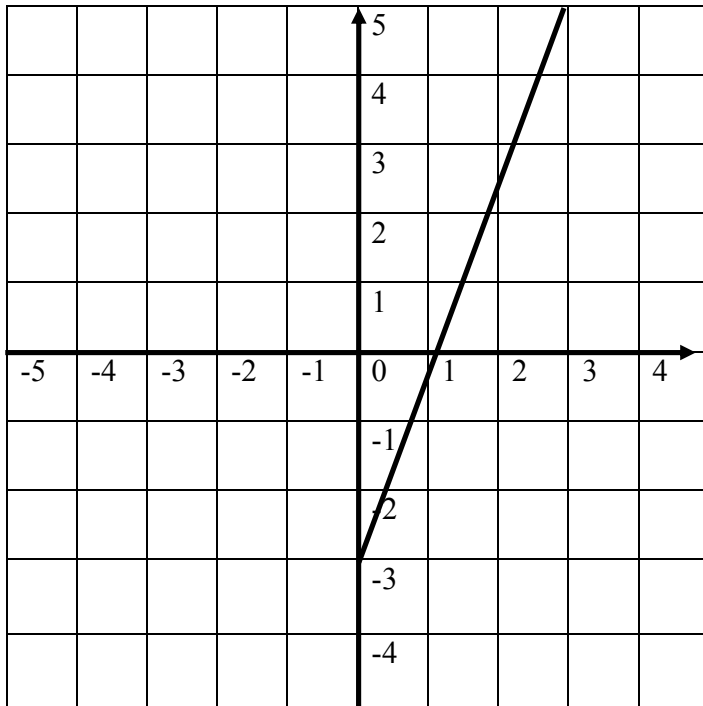

(A) $y = 8x - 3$

(B) $y = \frac{8}{3}x - 3$

(C) $y = -8x - 3$

(D) $8x = y$

16)

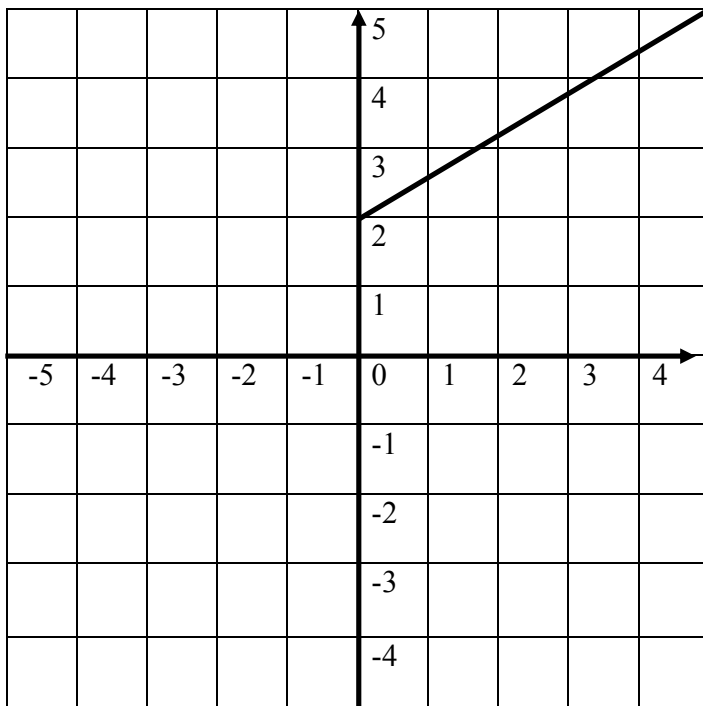

(A) $y = 2x + 2$

(B) $y = \frac{3}{5}x - 2$

(C) $y = \frac{3}{5}x + 2$

(D) $y = 3x + 5$

17)

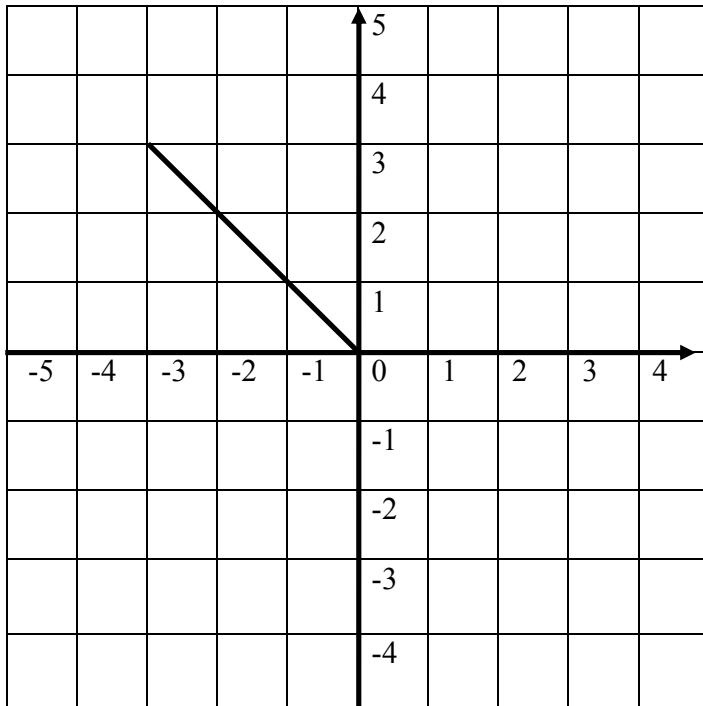

(A) $y = x$

(B) $y = x + 1$

(C) $y = x - 1$

(D) $y = -x$

18)

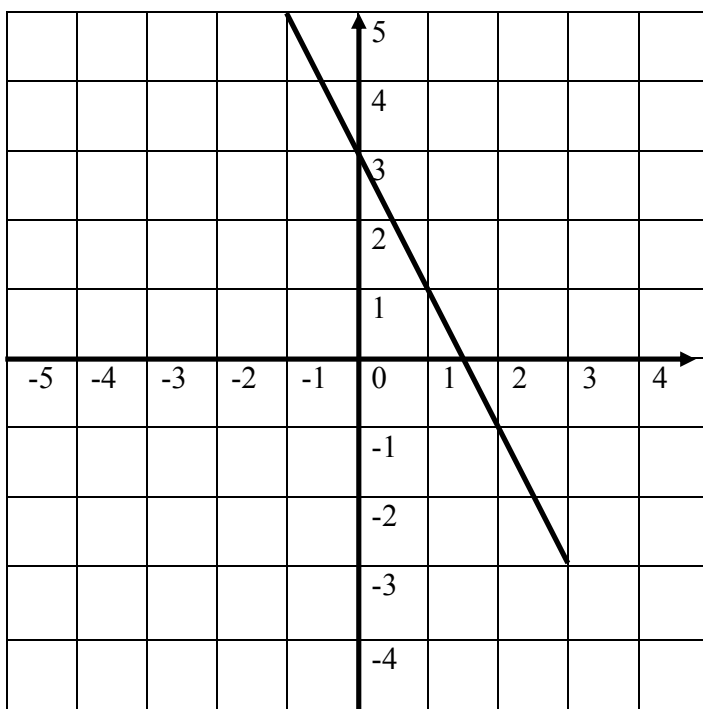

(A) $y = -2x + 3$

(B) $y = 2x + 3$

(C) $y = x - 1$

(D) $y = -x$

19)

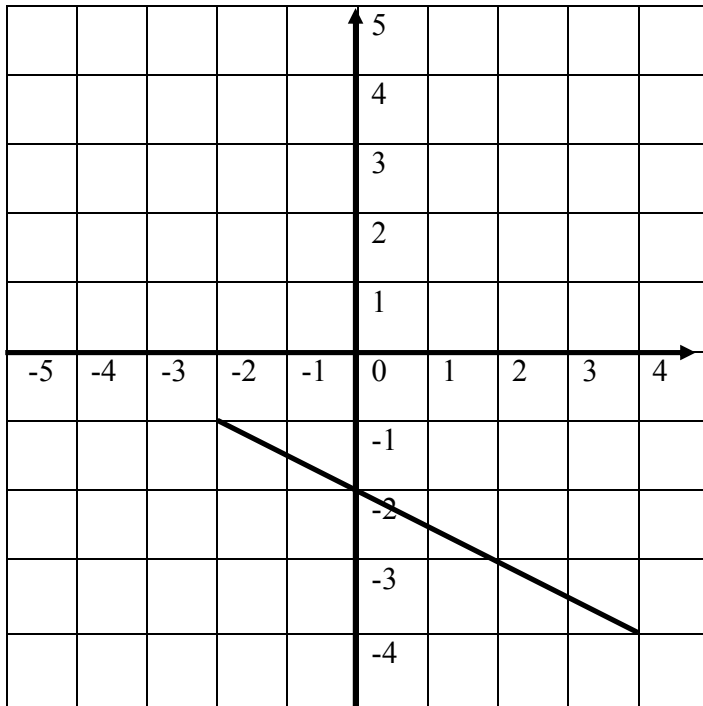

(A) $y = -2x - 2$

(B) $y = -\frac{1}{2}x - 2$

(C) $y = 2x - 2$

(D) $y = \frac{1}{2}x - 2$

20)

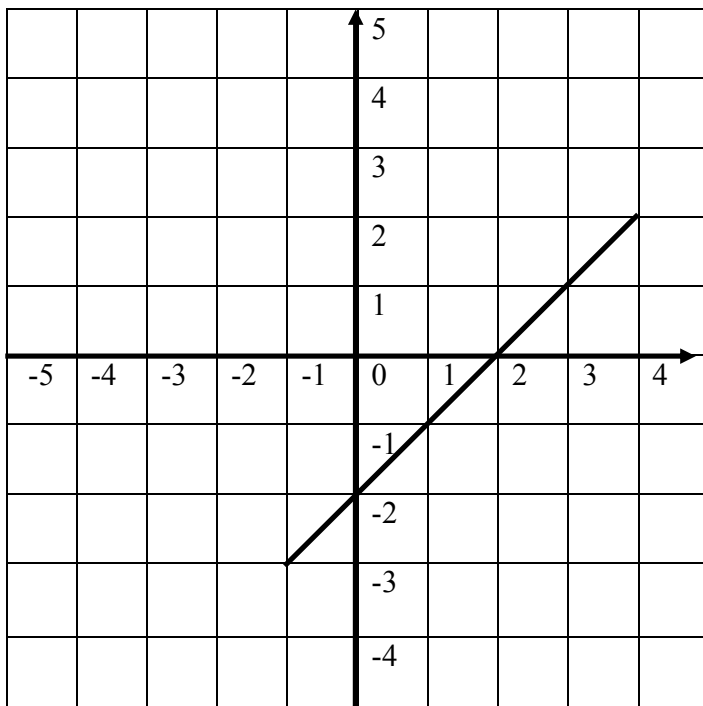

(A) $y = -2x - 2$

(B) $y = 2x - 2$

(C) $y = x - 2$

(D) $y = -x + 2$

TEST 4

1) $f: x \rightarrow x^2$ and $x \in \{1, 2, 3, 4\}$. Which set is the correct one for the function?

(A) $\{(1, 1), (2, 2), (3, 3), (4, 4)\}$ (B) $\{(1, 1), (2, 4), (3, 9), (4, 16)\}$

(C) $\{(1, 2), (2, 4), (3, 6), (4, 8)\}$ (D) $\{(1, 1), (2, 3), (3, 5), (4, 7)\}$

2) $f(x) = \frac{4x-3}{7}$ Find $f(-8)$

(A) -5 (B) -4 (C) 5 (D) 4

3) $f(x) = x^2$, find $f(-2)$

(A) -8 (B) -4 (C) 4 (D) -2

4) $f: x \rightarrow x^2$. Find the range for the values $\{-3, -2, -1, 0, 1, 2, 3\}$.

(A) $\{-3, -2, -1, 0, 1, 2, 3\}$ (B) $\{-6, -4, -3, 0, 2, 4, 6\}$

(C) $\{-9, -4, -1, 0, 1, 4, 9\}$ (D) $\{9, 4, 1, 0, 1, 4, 9\}$

5) $f(x) = \frac{4x-3}{5}$ Find $f(-3)$

(A) 3 (B) -3 (C) $\frac{9}{5}$ (D) $-\frac{9}{5}$

6) $f: x \rightarrow x^2 + 3$ and $x \in \{1, 2, 3, 4, 5\}$. Which is the correct set?

(A) $\{(1, 4), (2, 7), (3, 12), (4, 19), (5, 28)\}$ (B) $\{(1, 3), (2, 4), (3, 5), (4, 6), (5, 7)\}$

(C) $\{(1, 4), (2, 5), (3, 6), (4, 7), (5, 8)\}$ (D) $\{(1, 1), (2, 2), (3, 3), (4, 4), (5, 5)\}$

7) $f(x) = 2x^2 - 3x - 1$, find $f(-2)$

- (A) -13 (B) 15 (C) 13 (D) 1

8) $f(s) \rightarrow x^3$. List the range for $\{-3, -2, -1, 0, 1, 2, 3\}$.

- (A) $\{27, 8, 1, 0, 1, 8, 27\}$ (B) $\{-3, -2, -1, 0, 1, 2, 3\}$
(C) $\{9, 4, 1, 0, 1, 4, 9\}$ (D) $\{-27, -8, -1, 0, 1, 8, 27\}$

9) $f(x) = 3x^2 - 3$, find $f(-4)$

- (A) 45 (B) -51 (C) -45 (D) 9

10) $f(x) = 4x^2 - 3$, find $f(-2)$

- (A) 5 (B) -19 (C) 13 (D) 19

11) $f(h) \rightarrow x^2 + 5$. Which set represents ordered pairs for this function?

- (A) $\{(1, 6), (2, 7), (3, 8), (4, 9)\}$ (B) $\{(1, 5), (2, 5), (3, 5), (4, 5)\}$
(C) $\{(1, 1), (2, 2), (3, 3), (4, 4)\}$ (D) $\{(1, 6), (2, 9), (3, 14), (4, 21)\}$

12) $f(g) = 2x^2 - 3x + 2$, find $f(2)$

- (A) 2 (B) 4 (C) 16 (D) 12

13) $f(p) \rightarrow x^2$. Which is the range for the domain $\{-3, -2, -1, 0, 1, 2, 3\}$

- (A) $\{9, 4, 1, 0, 1, 4, 9\}$ (B) $\{-3, -2, -1, 0, 1, 2, 3\}$
(C) $\{-6, -4, -2, 0, 2, 4, 6\}$ (D) $\{0, 1, 2, 3, 4, 5, 6\}$

14) $f(m) = 3x^2 - 4x - 2$, find $f(4)$

- (A) 66 (B) -6 (C) 30 (D) -30

15) $f(p) = 3x^2 - 4x - 2$, find $f(-1)$

- (A) -5 (B) 5 (C) 9 (D) 7

16) $f(q) = 3x^2 - 4x - 1$, find $f(-2)$

- (A) 21 (B) -3 (C) 3 (D) 19

17) $f(r) = \frac{2x-3}{2}$ Find $f(-2)$

- (A) $-\frac{7}{2}$ (B) $\frac{7}{2}$ (C) $\frac{1}{2}$ (D) $-\frac{1}{2}$

18) $f(a) = \frac{5x-2}{3}$ Find $f(4)$

- (A) 7 (B) 7.5 (C) 6 (D) 8

19) $f(b) = x^2 - x - 2$, find $f(1)$

- (A) 2 (B) 4 (C) -4 (D) -2

20) $f(c) = 4x^2 + 2x - 3$, find $f(-1)$

- (A) 1 (B) -1 (C) 3 (D) -3

TEST 5

1) A train covers a distance of 500 km in $2\frac{1}{2}$ hours. Find its speed.

- (A) 1250 km/h (B) 200 km/h (C) 300 km/h (D) 250 km/h

2) The Shinkansen train covers a distance of 1500 km in 12 hours. Find its speed.

- (A) 125 km/h (B) 150 km/h (C) 18000 km/h (D) 750 km/h

3) A train starts a journey at 17:00 hours and arrives at its destination at 23:30 hours. How long was this journey?

- (A) 6 h (B) 7.5 h (C) 5.5 h (D) 6.5 h

4) A boat leaves port A at 8:00 hours and arrives at port B at 13:30 hours. The speed of the boat was 80 km/h. What was the distance covered?

- (A) 400 km (B) 350 km (C) 440 km (D) 450 km

5) A truck covers a distance of 120 km in $4\frac{1}{2}$ hours. Find its speed.

- (A) 26 km/h (B) 26.7 km/h (C) 27 km/h (D) 28 km/h

6) An aircraft departs an airport at 19:15 hours and reaches its destination at 3:00 hours next morning. It travels at a speed of 500 km/hour. What was the distance it travelled?

- (A) 3800 km (B) 4000 km (C) 4500 km (D) 3875 km

7) A train covers a distance of 160 km in $2\frac{1}{2}$ hours. Find its speed.

- (A) 64 km/h (B) 65 km/h (C) 70 km/h (D) 62 km/h

8) Caribbean Airlines left Piarco International Airport at 17:30 hours and arrived at its destination at 20:45 hours. What was the duration of this flight?

- (A) 3.5 hrs (B) 3 hrs (C) 3.25 hrs (D) 3.5 hrs

9) A Teacher leaves home at 6:45 hours and arrives to work at 7:45 hours. She drove at a speed of 80 km/h. How far is the School from her home?

- (A) 70 km (B) 80 km (C) 60 km (D) 90 km

10) A ferry leaves Port of Spain at 22:15 hours and arrives at Scarborough at 3:00 hours next morning. How long was this journey?

- (A) $4\frac{1}{2}$ hrs (B) $3\frac{3}{4}$ hrs (C) $4\frac{1}{4}$ hrs (D) $4\frac{3}{4}$ hrs

11) Tokyo to Osaka is 400 km. A bullet train covers this distance non stop in 4 hours. What is its speed?

- (A) 100 km/h (B) 1600 km/h (C) 150 km/h (D) 200 km/h

12) An aircraft departs airport A at 19:15 hours and arrives at its destination at 5:00 hours next morning. How long was the journey?

- (A) $8\frac{3}{4}$ hrs (B) $9\frac{3}{4}$ hrs (C) $9\frac{1}{4}$ hrs (D) $8\frac{3}{4}$ hrs

13) What does a distance-time graph shows?

- (A) The distance of an object.
(B) The time of a movement.
(C) Distance and time.
(D) The distance covered by a body at different time intervals.

14) What does a velocity-time graph shows?

- (A) The velocity of a body at different time intervals.
- (B) A velocity
- (C) The times
- (D) None of the above.

QUESTIONS 15 TO 18 ARE BASED ON THE VELOCITY TIME GRAPH BELOW.

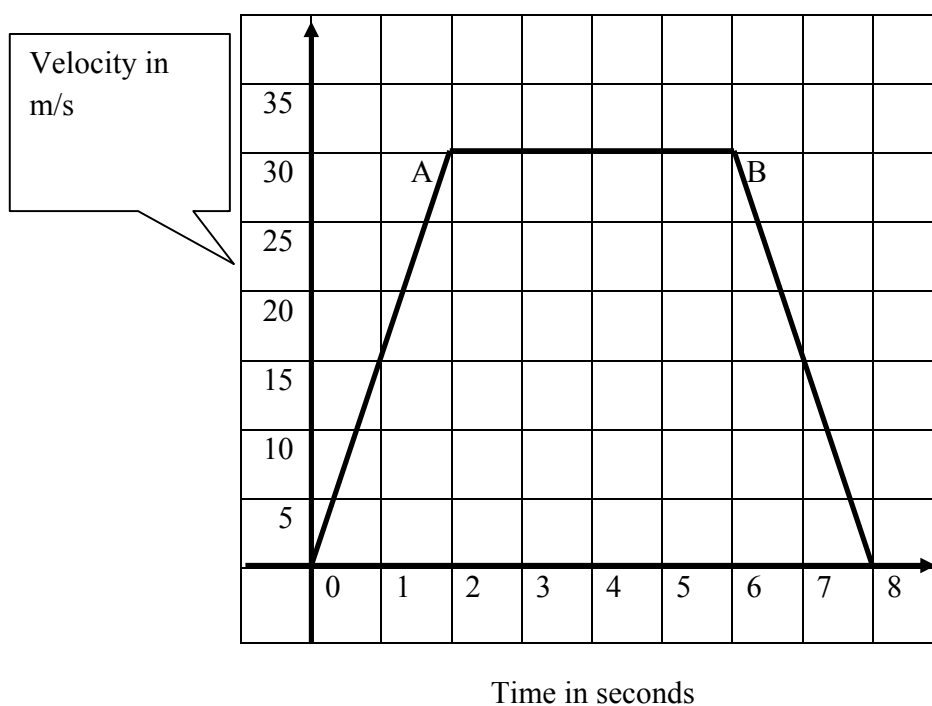

15) What is the acceleration of the body?

- (A) 30 m/s^2
- (B) 60 m/s^2
- (C) 45 m/s^2
- (D) 15 m/s^2

16) What is the deceleration of the body?

- (A) 30 m/s^2
- (B) 60 m/s^2
- (C) 45 m/s^2
- (D) 15 m/s^2

17) What is the value of the constant velocity of the body?

- (A) 30 m/s (B) 60 m/s (C) 45 m/s (D) 15 m/s

18) What is the total distance covered by the body?

- (A) 200 m (B) 150 m (C) 180 m (D) 250 m

19) Calculate the acceleration of a particle if its velocity is 200 m/s and its time of movement is 6 seconds.

- (A) 30.3 m/s^2 (B) 33.3 m/s^2 (C) 66.3 m/s^2 (D) 1200 m/s^2

20) The diagram shows the velocity of an experimental body in a laboratory. Find the total distance covered.

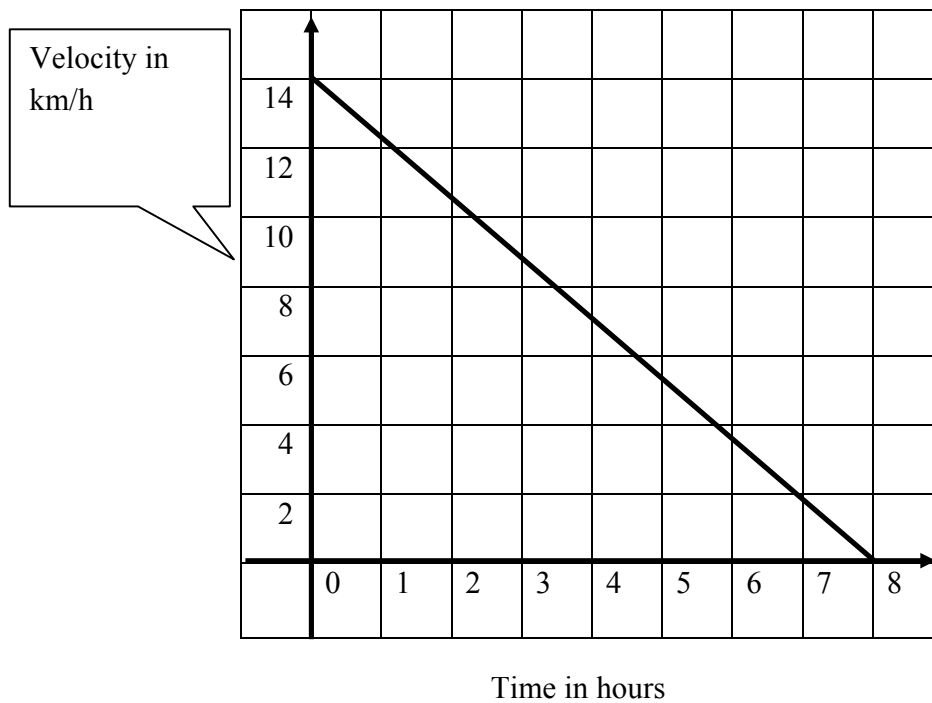

- (A) 112 km (B) 100 km (C) 56 km (D) 14 km

TEST 6

Questions 1 to 4 are based on Figure 1.

Figure 1

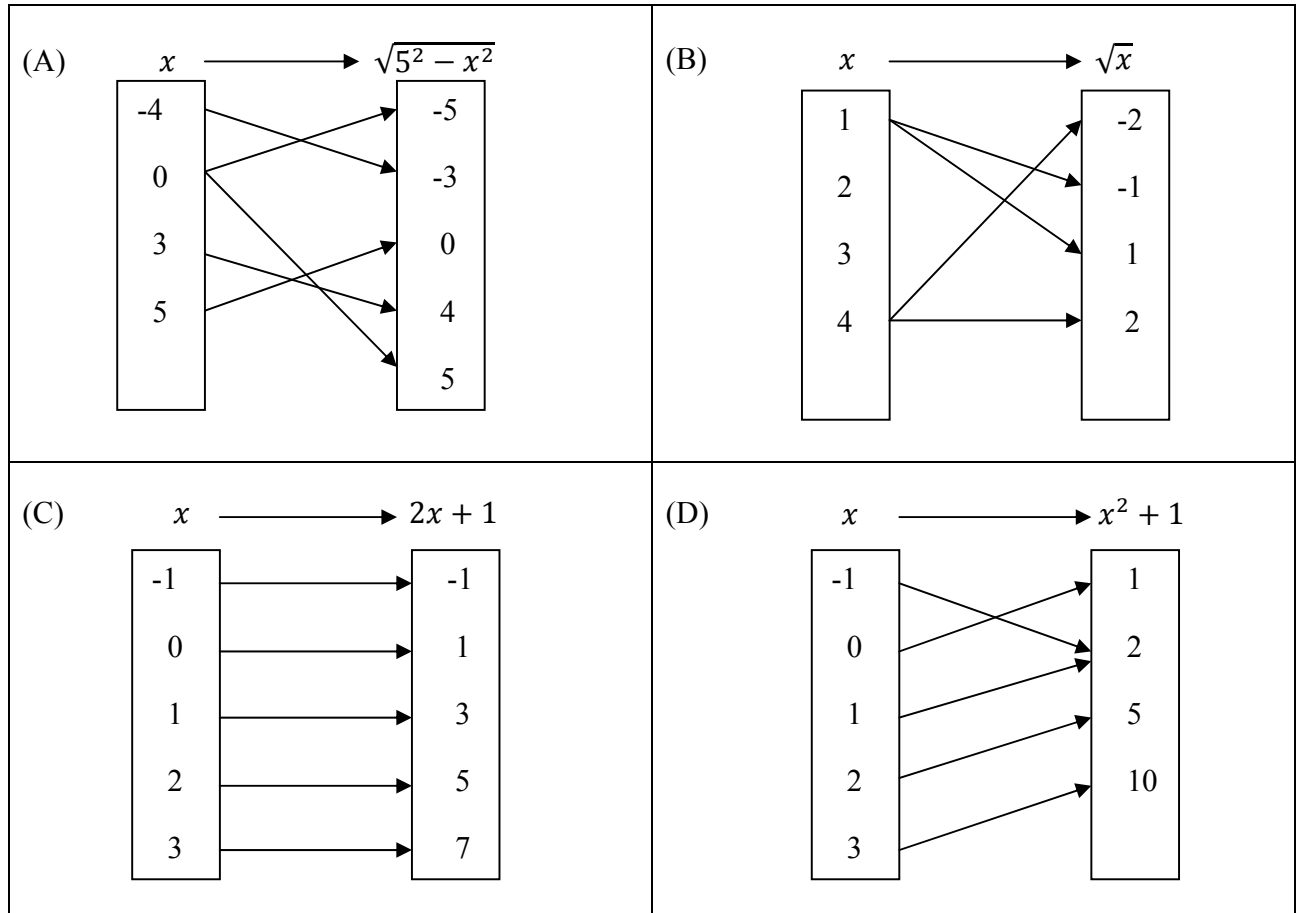

1) Which arrow diagram represents a one to one mapping?

(A) (B) (C) (D)

2) Which arrow diagram represents a one to many mapping?

(A) (B) (C) (D)

3) Which arrow diagram represents a many to one mapping?

(A) (B) (C) (D)

4) Which arrow diagram represents a many to many mapping?

(A) (B) (C) (D)

5) Which one is correct for the arrow diagram?

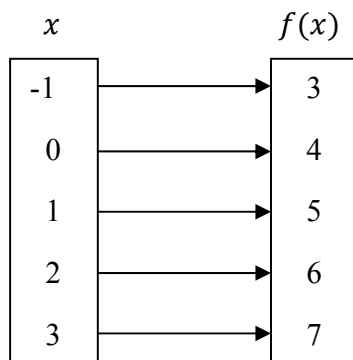

(A) $f(x): x \rightarrow x + 3$

(B) $f(x): x \rightarrow 2x + 2$

(C) $f(x): x \rightarrow x + 4$

(D) $f(x): x \rightarrow 2x + 1$

6) Which function represents the arrow diagram?

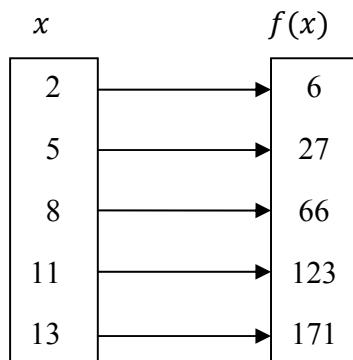

(A) $f(x): x \rightarrow x^2 + 1$

(B) $f(x): x \rightarrow 2x^2$

(C) $f(x): x \rightarrow x^2 + 2$

(D) $f(x): x \rightarrow x^2 + 3$

7) Which answer best describes the arrow diagram?

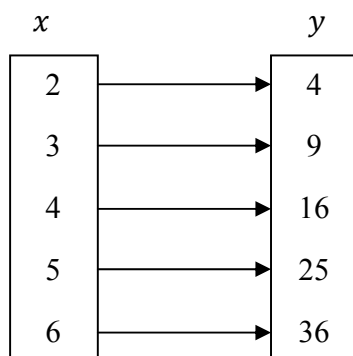

(A) x is the square root of y

(B) x is half of y

(C) x is one third of y

(D) y is twice x

8) Which function is correct for the arrow diagram?

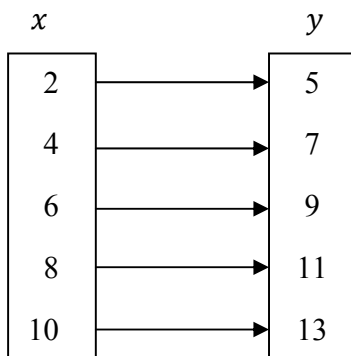

(A) $f(x) = x + 3$

(B) $f(x) = y + 3$

(C) $x = y + 2$

(D) $y = x$

9) Which answer best describes the arrow diagram?

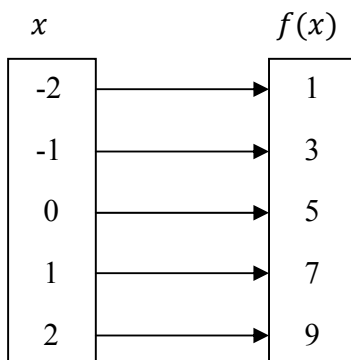

(A) $f(x) = 2x + 3$

(B) $f(x) = 3x + 1$

(C) $f(x) = 4x - 5$

(D) $f(x) = 2x + 5$

Complete the arrow diagrams from 10 to 20.

10) $x \longrightarrow x^2$

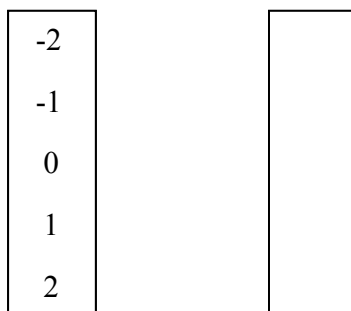

11) $x \longrightarrow x^2 + 1$

-2	
-1	
0	
1	
2	

12) $x \longrightarrow x^2 + 2$

-2	
-1	
0	
1	
2	

13) $x \longrightarrow 2x + 1$

-2	
-1	
0	
1	
2	

14) $x \longrightarrow 4x - 1$

-2	
-1	
0	
1	
2	

15) $x \longrightarrow 3x - 1$

-2	
-1	
0	
1	
2	

16) $x \longrightarrow x^2 - 1$

1	
2	
3	
4	
5	

17) $x \longrightarrow x^2 + 2x + 1$

1	
2	
3	
4	
5	

18) $x \longrightarrow x^2 + x + 2$

1	
2	
3	
4	
5	

19) $x \longrightarrow 2x^2 + x - 1$

1	
2	
3	
4	
5	

20) $x \longrightarrow 2x^2 + 2x - 1$

1
2
3
4
5

--

The following questions are based on the table. Your Teacher will show you how to use the **Vertical Line Test**.

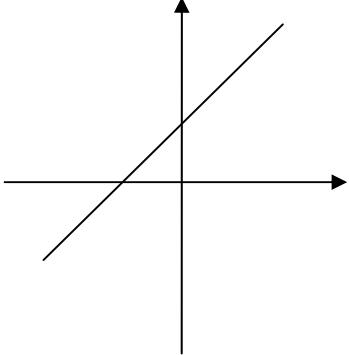
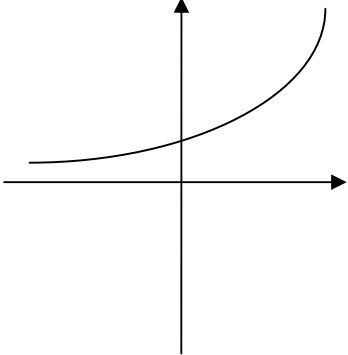
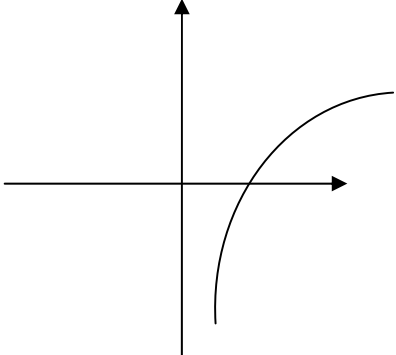
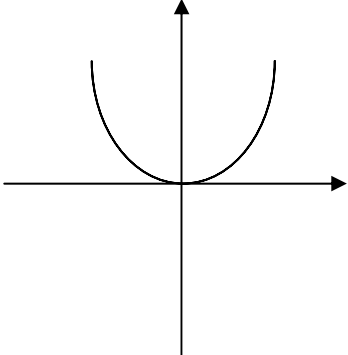
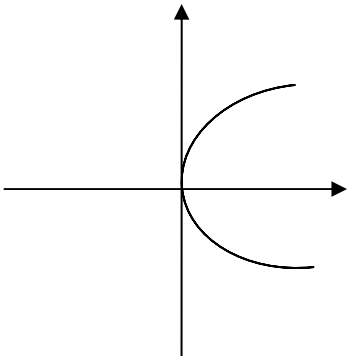
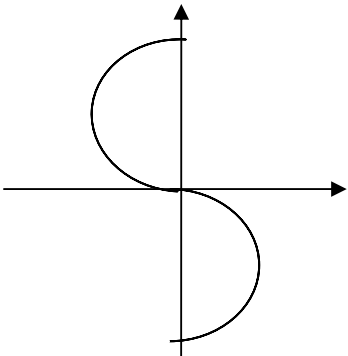
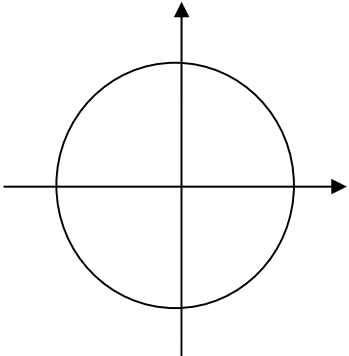
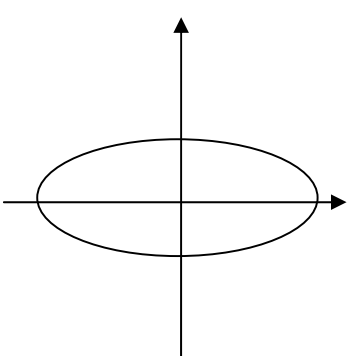
(A) 	(B) 
(C) 	(D) 
(E) 	(F) 
(G) 	(H) 

21) Which graphs are one to one mapping?

22) Which graphs are one to many mapping?

23) Which graphs are many to one mapping?

24) Which graphs are many to many mapping?

25) Which graph is a function in the diagrams below? Use the **Vertical Line Test**.

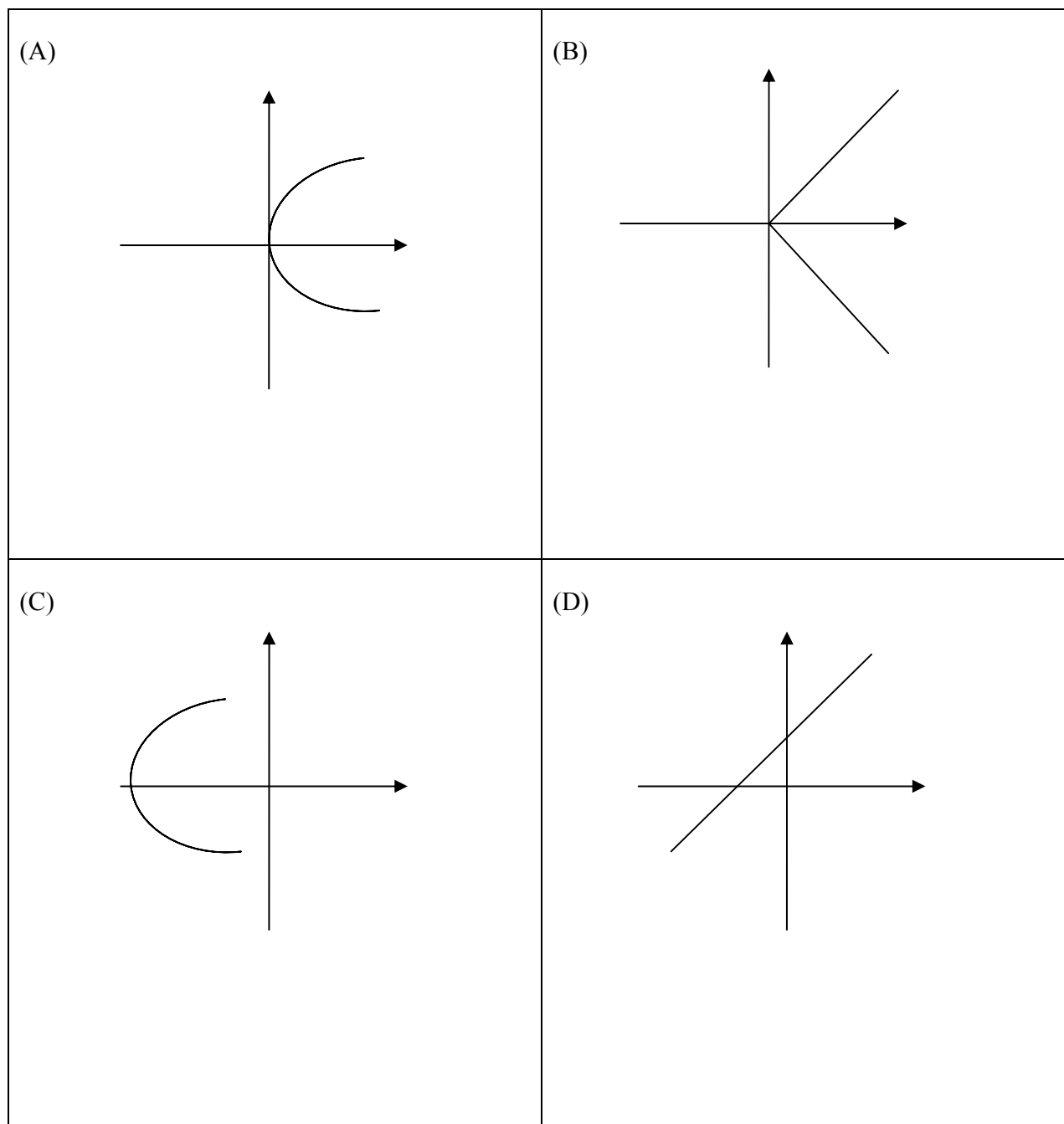

8 Geometry and Trigonometry

TEST 1

Pythagoras' Theorem

1) Label hypotenuse, side a and side b.

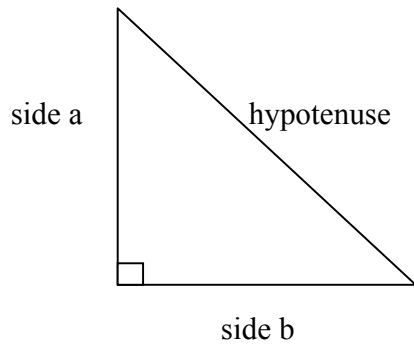

2) Label hypotenuse, side x and side y.

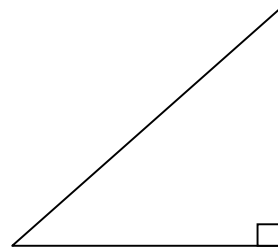

3) Label hypotenuse, a and b.

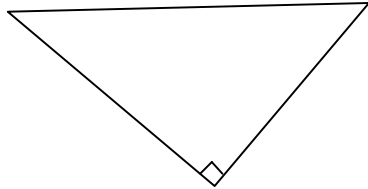

4) Label hypotenuse, 3 m and 4 m.

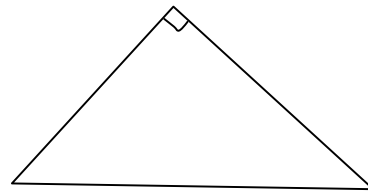

5) Label hypotenuse, 5 cm and 12 cm.

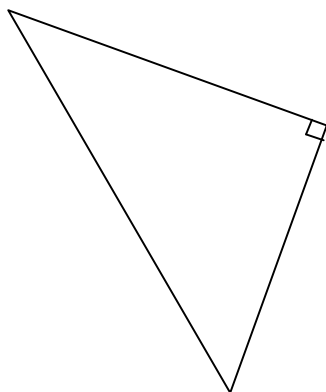

6) Label hypotenuse, 6 cm and 8 cm.

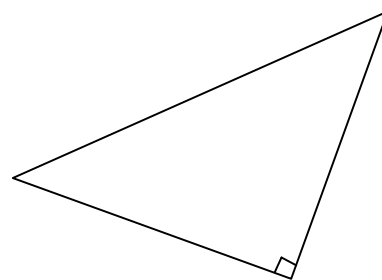

Use Pythagoras' Theorem to work the following.

7)

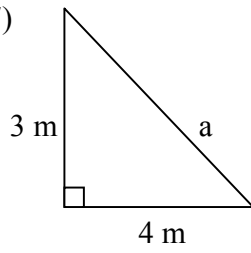

8)

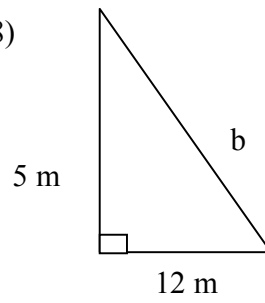

9)

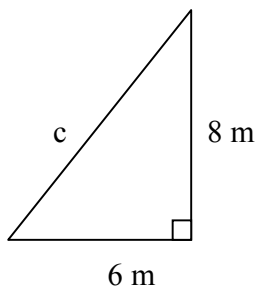

10)

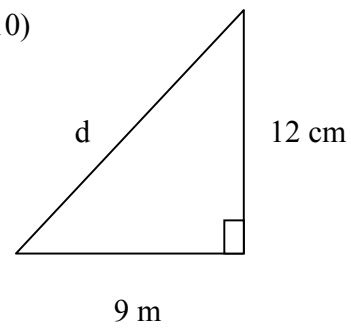

11)

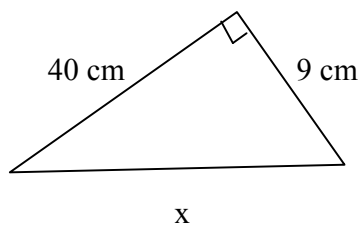

12)

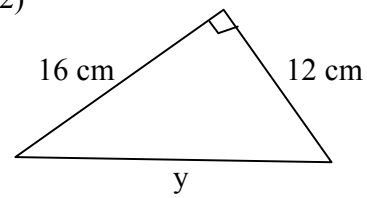

Use Pythagoras' Theorem to work the following.

13)

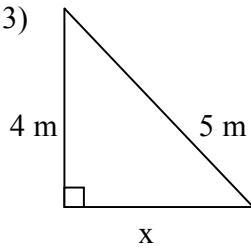

14)

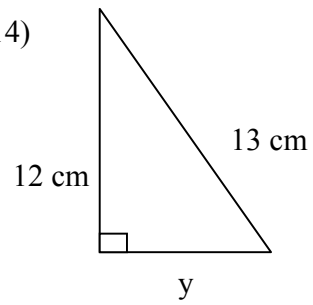

15)

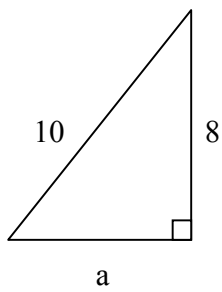

16)

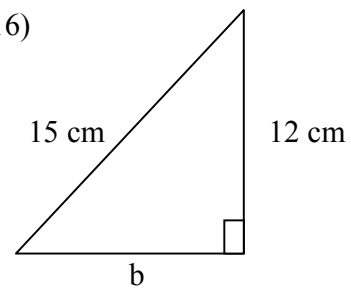

17)

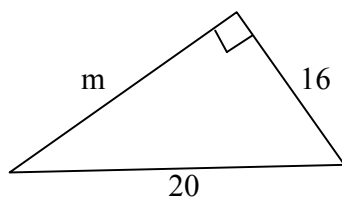

18)

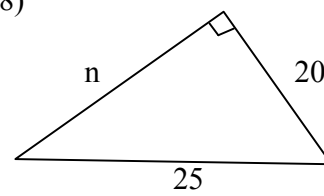

19) Which one of the following is not Pythagoras' theorem?

(A) $\text{hypotenuse}^2 = a^2 + b^2$

(B) $a^2 = b^2 + c^2$

(C) $\text{hypotenuse}^2 = x + y$

(D) The square of the hypotenuse is equal to the sum of the squares on the other two sides of a right angled triangle.

20) A ladder is 5 m in length. It leans against a wall that is 4 m high. The base of the ladder is 3 m away from the base of the wall. Draw a diagram to show this.

21) A light pole is 20 m high. A cable 25 m in length is attached to the top of the pole to keep it stable. The other end of the cable is anchored to the ground and it is 15 m away from the base of the pole. Show this on a diagram.

22) A building is 16 m high and it can be reached by a 20 m long ladder. The base of the ladder is 12 m away from the base of the building. Show this on a diagram.

23) Use Pythagoras' Theorem to calculate the lengths of x and y .

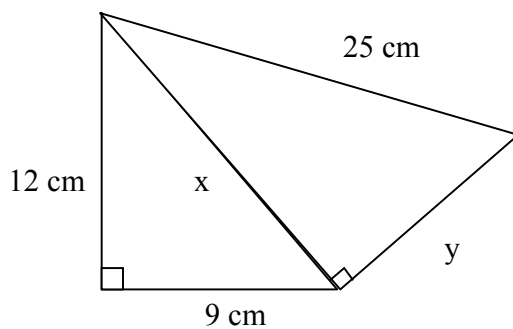

- (A) $x = 15$ and $y = 20$
 (B) $x = 12$ and $y = 20$
 (C) $x = 10$ and $y = 18$
 (D) $x = 85$ and $y = 25$

24) Use Pythagoras' Theorem to calculate the lengths of x and y .

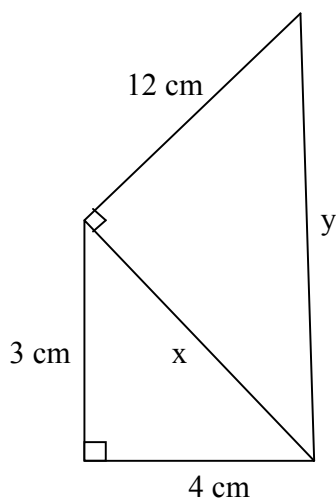

- (A) $x = 6$ and $y = 20$
 (B) $x = 9$ and $y = 15$
 (C) $x = 8$ and $y = 12$
 (D) $x = 5$ and $y = 13$

TEST 2

Trigonometry: $\sin \theta$, $\tan \theta$ and $\cos \theta$ Label **hypotenuse**, **opposite side** and **adjacent side** in the following.

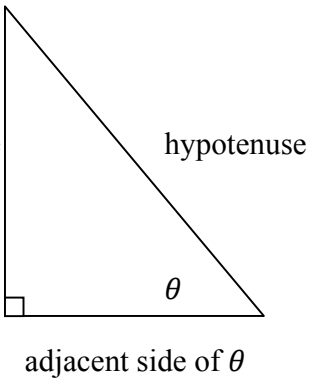
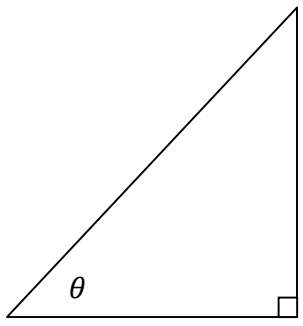
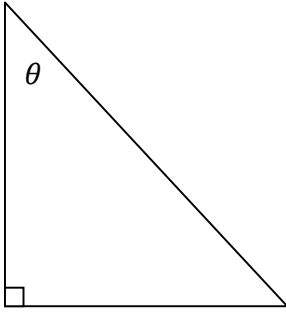
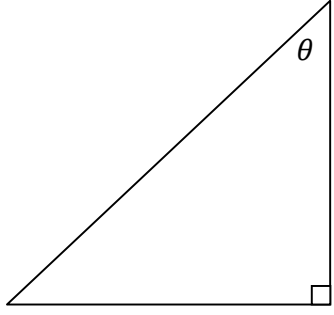
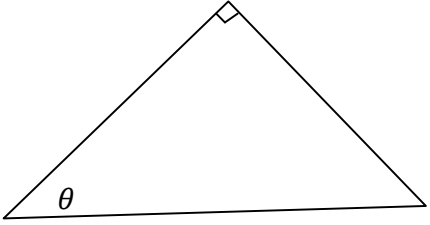
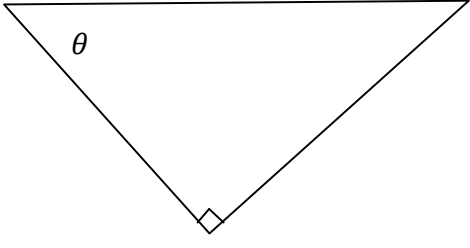
<p>1)</p> 	<p>2)</p> 
<p>3)</p> 	<p>4)</p> 
<p>5)</p> 	<p>6)</p> 

$$\sin \theta = \frac{\text{opposite side}}{\text{hypotenuse}}$$

Write $\sin \theta$ as a fraction.

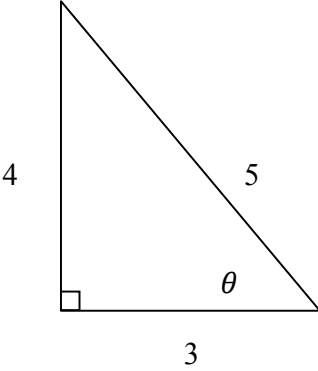
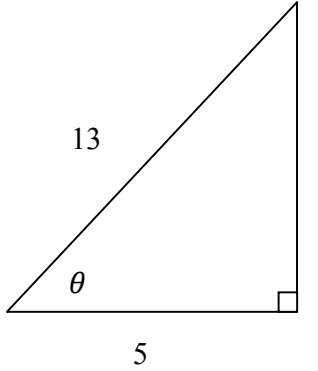
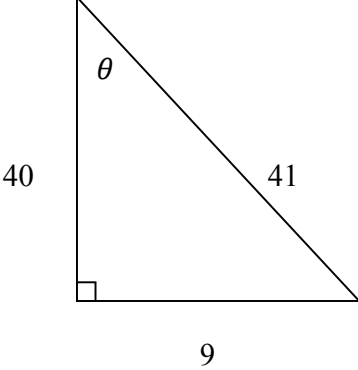
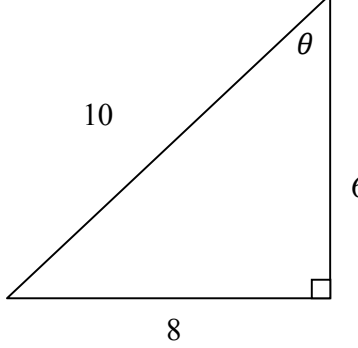
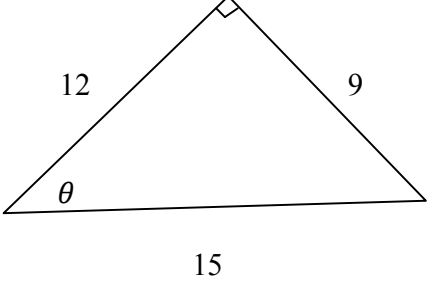
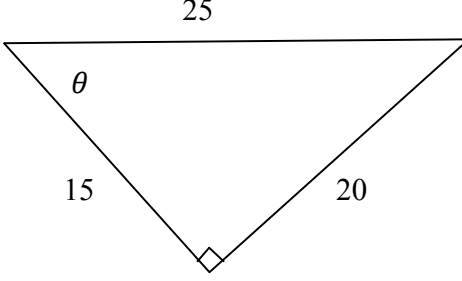
7) 	8) 
9) 	10) 
11) 	12) 

$$\tan \theta = \frac{\text{opposite side}}{\text{adjacent side}}$$

Write $\tan \theta$ as a fraction.

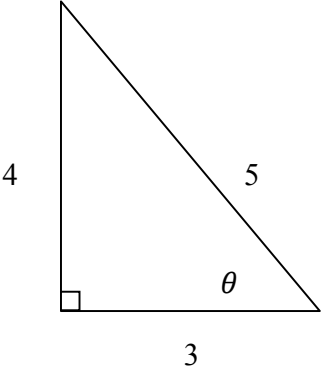
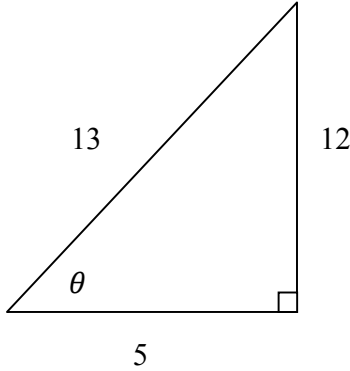
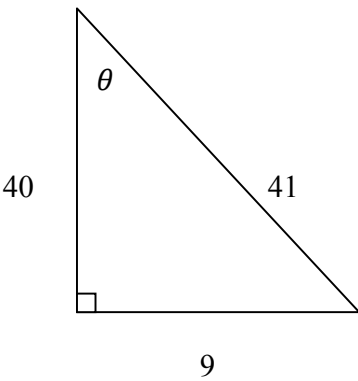
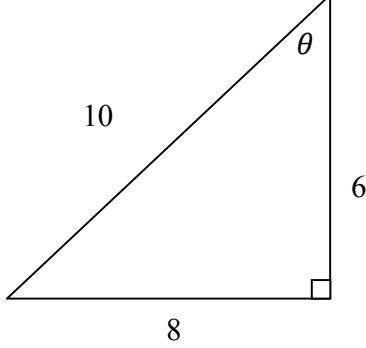
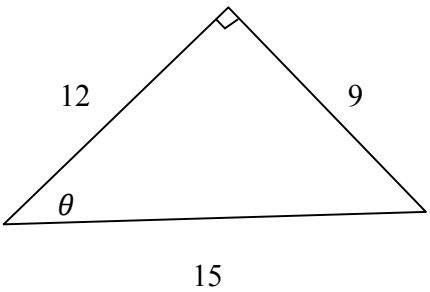
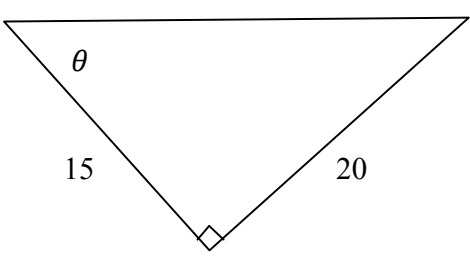
<p>13)</p> 	<p>14)</p> 
<p>15)</p> 	<p>16)</p> 
<p>17)</p> 	<p>18)</p> 

$$\cos \theta = \frac{\text{adjacent side}}{\text{hypotenuse}}$$

Write $\cos \theta$ as a fraction.

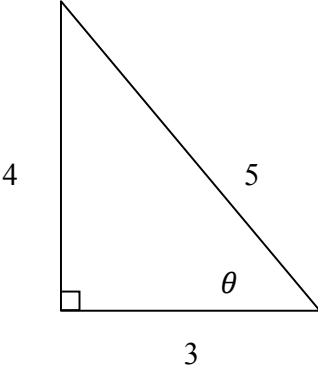
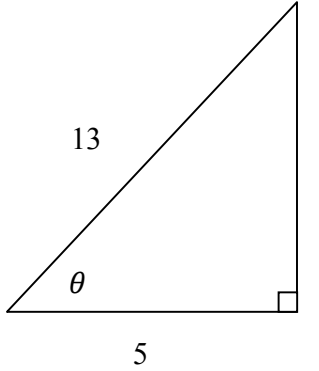
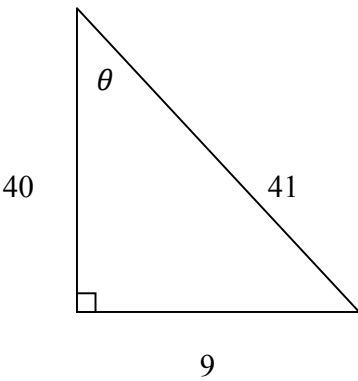
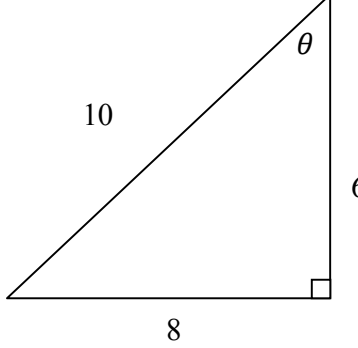
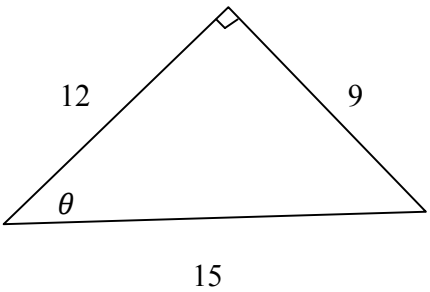
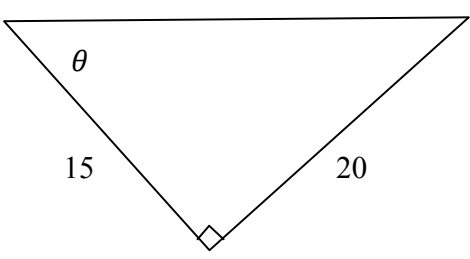
<p>19)</p> 	<p>20)</p> 
<p>21)</p> 	<p>22)</p> 
<p>23)</p> 	<p>24)</p> 

TEST 3

Angle of elevation and angle of depression

Label the **angle of elevation** and **angle of depression** in the following.

<p>1)</p>	<p>2)</p>
<p>3)</p>	<p>4)</p>
<p>5)</p>	<p>6)</p>

Angle of elevation = angle of depression

Write in the unknown angles.

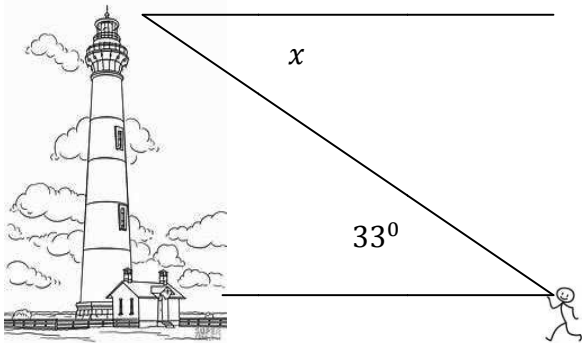
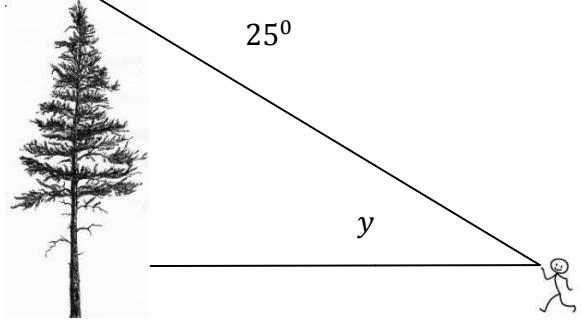
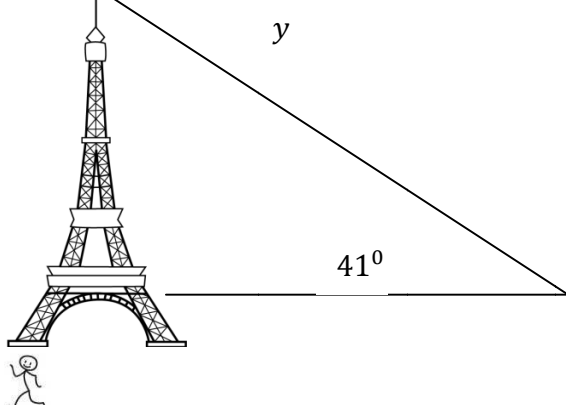
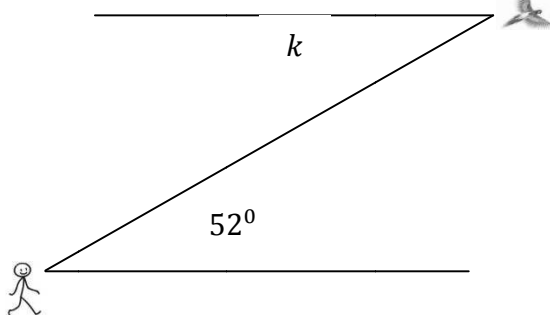
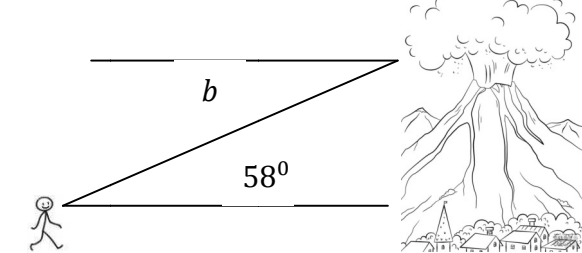
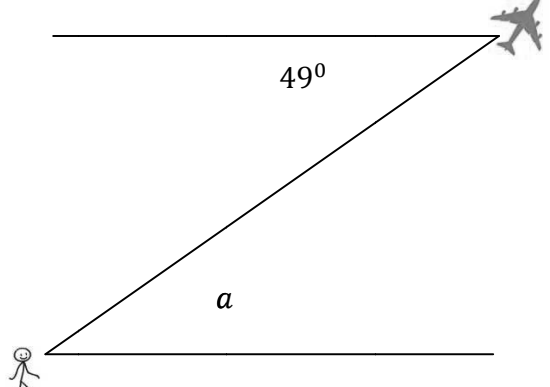
<p>7)</p> 	<p>8)</p> 
<p>9)</p> 	<p>10)</p> 
<p>11)</p> 	<p>12)</p> 

Find h in the following.

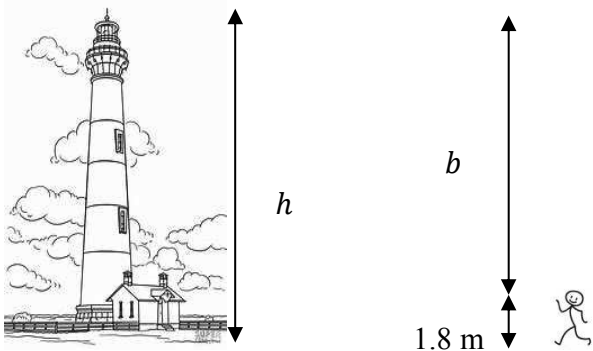
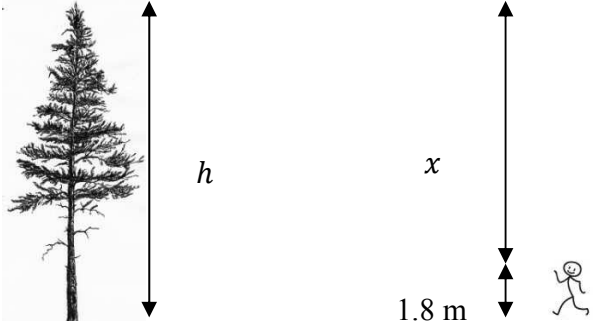
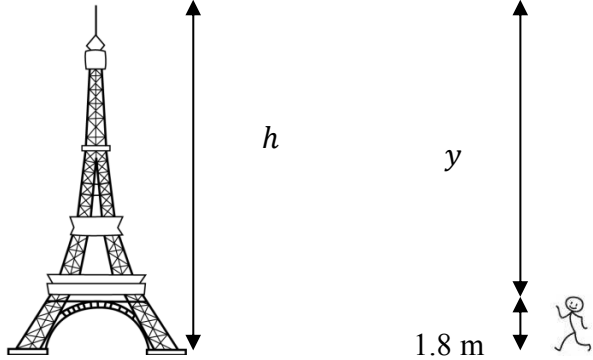
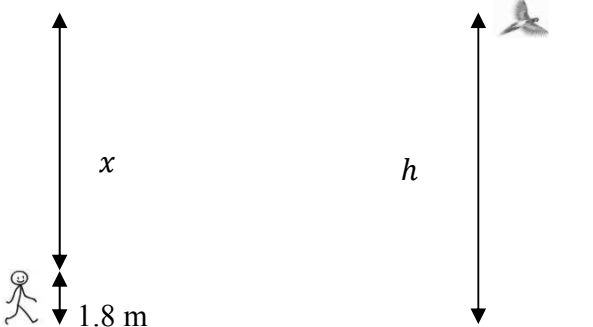
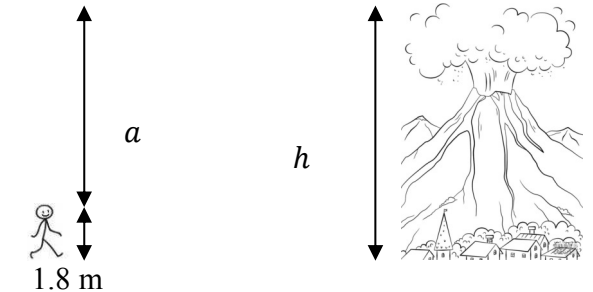
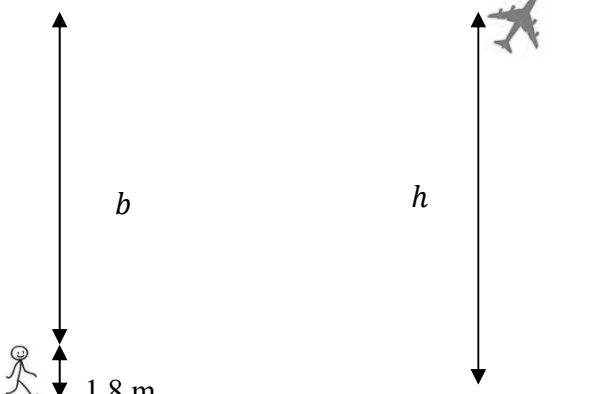
<p>13)</p> 	<p>14)</p> 
<p>15)</p> 	<p>16)</p> 
<p>17)</p> 	<p>18)</p> 

E.g.) A man is 1.8 m tall, stands 16 m away from a building. He looks up at the top of the building because he heard something there. His angle of elevation to the top of the building is 50° . Find the height of the building.

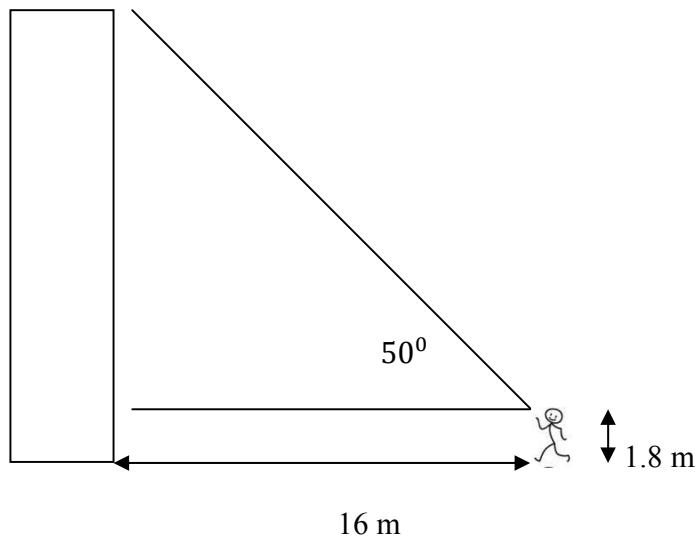

This is the diagram that represents the information. The diagram below is needed for the calculation. We need to find x first.

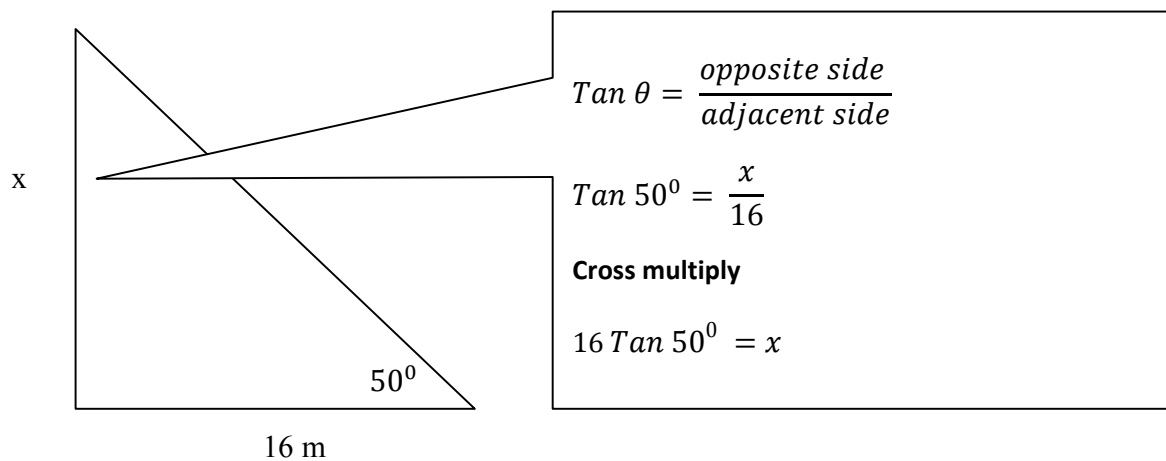

Therefore height of building = $1.8 + 16 \tan 50^\circ$

This can also be written as $16 \tan 50^\circ + 1.8$

Do these like in the example.

19) Find the height of the tree.

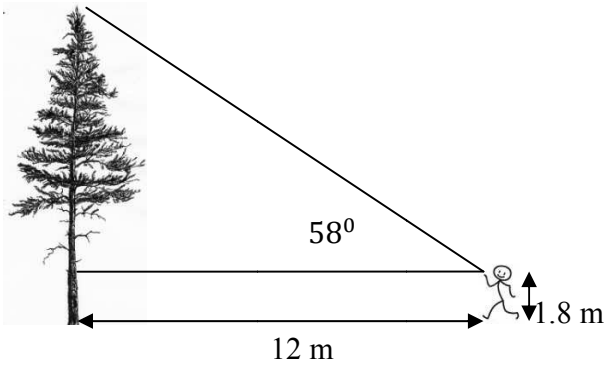

20) Find the height of the tower.

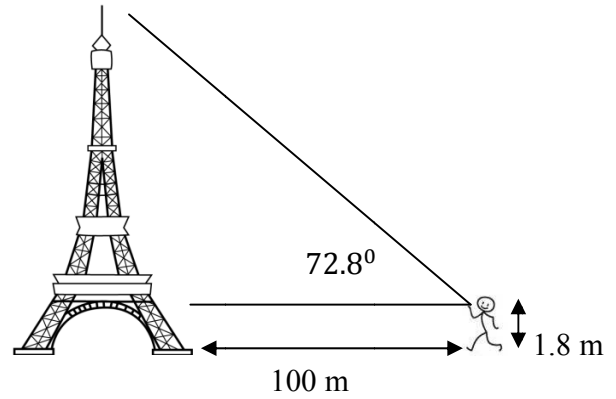

21) Find the height of the lighthouse.

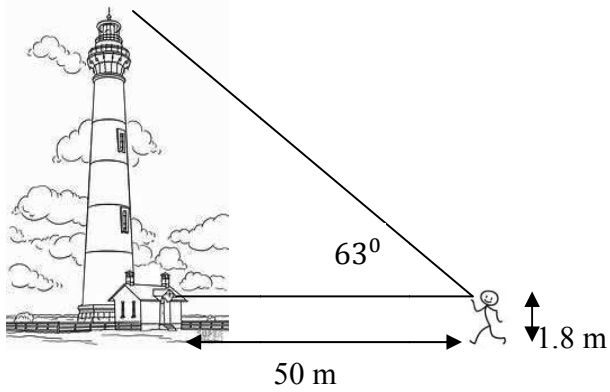

22) Find the height of the aeroplane.

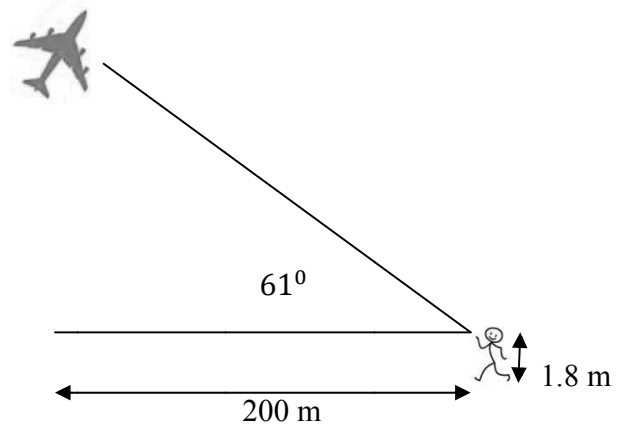

TEST 4

1) What is angle a in the isosceles triangle?

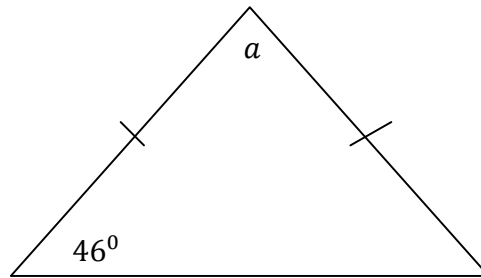

- (A) 80°
 (B) 88°
 (C) 90°
 (D) 85°

2) What is angle b ?

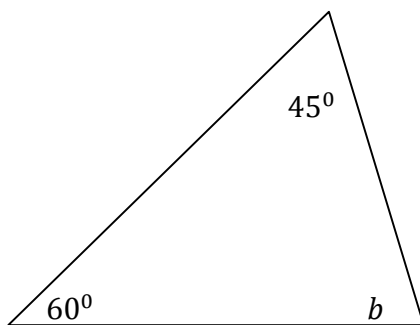

- (A) 75°
 (B) 80°
 (C) 90°
 (D) 70°

3) Find angle c .

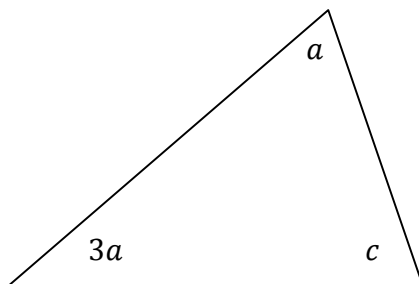

- (A) $c - 4a$
 (B) $c + 4a$
 (C) $180^\circ - 4a$
 (D) $180^\circ - 4a - c$

4) What is angle C?

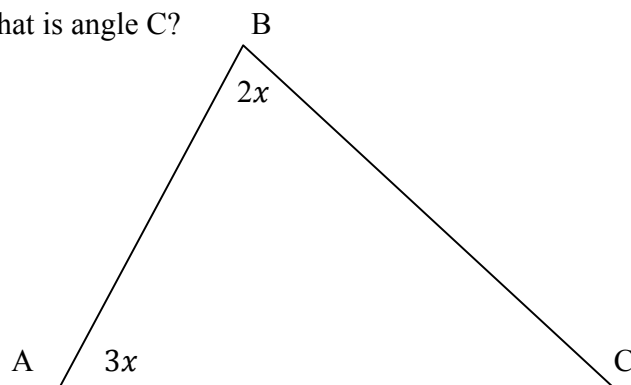

- (A) $C - 5x$
 (B) $2x + 3x$
 (C) $180^\circ - 5x$
 (D) $180^\circ - 5x - C$

5) Find angle m .

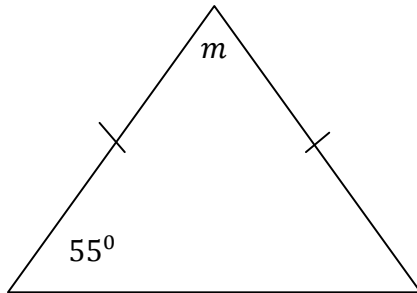

- (A) $55^\circ + m$
 (B) 70°
 (C) $90^\circ - m$
 (D) $55^\circ + m + n$

6) Find angle z .

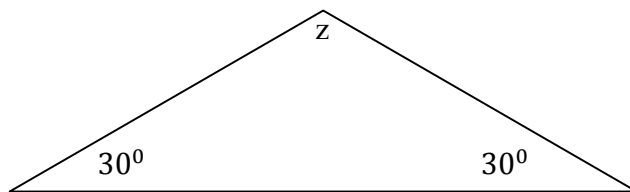

- (A) 120° (B) 130°
 (C) 100° (D) 125°

7) What is angle y ?

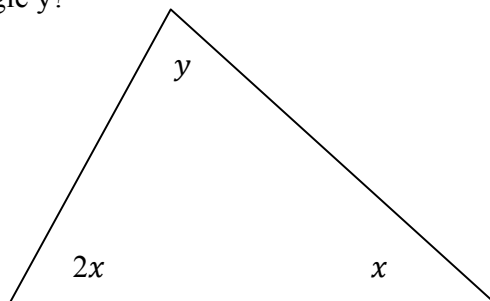

- (A) $180^\circ + 3x$
 (B) $180^\circ - 3x$
 (C) $90^\circ - x$
 (D) $3x - y$

8) What is the relationship between *angle a* and *angle b*?

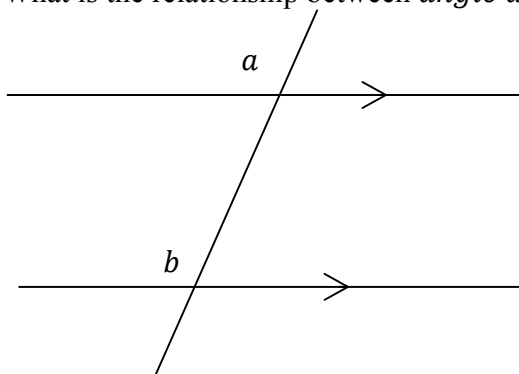

- (A) $a > b$
 (B) $180^\circ - a = b$
 (C) $180^\circ - b = a$
 (D) $a = b$

9) What can you say about the two unknown angles in the diagram?

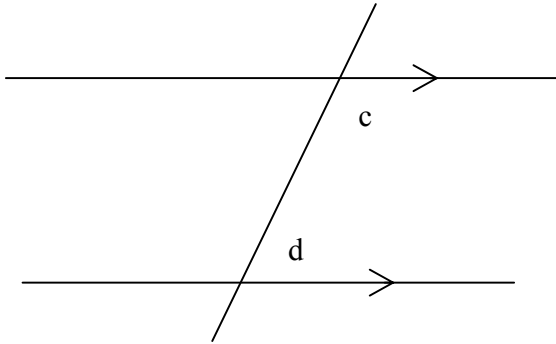

- (A) $c > d$
 (B) $180^\circ - a = b$
 (C) $180^\circ = c + d$
 (D) $c = d$

10) How can both angles be described in the figure?

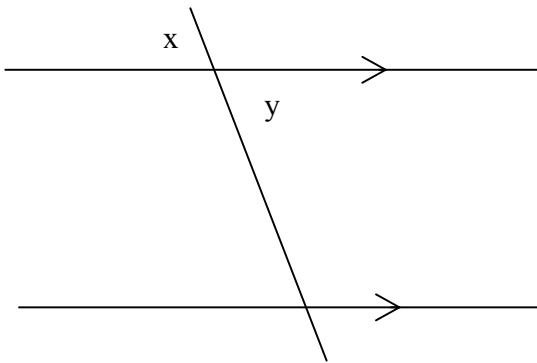

- (A) Corresponding
 (B) Vertically opposite
 (C) Supplementary
 (D) Alternate

11) What can you say about both angles?

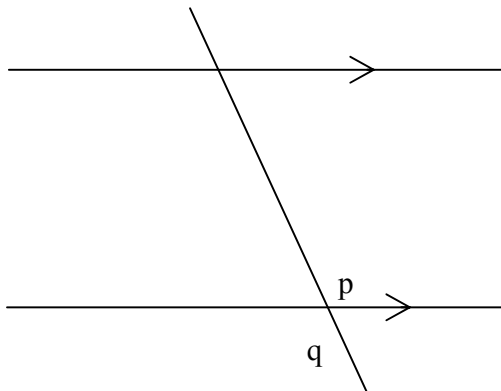

- (A) Corresponding
 (B) Vertically opposite
 (C) Supplementary
 (D) Alternate

12) Calculate angle a

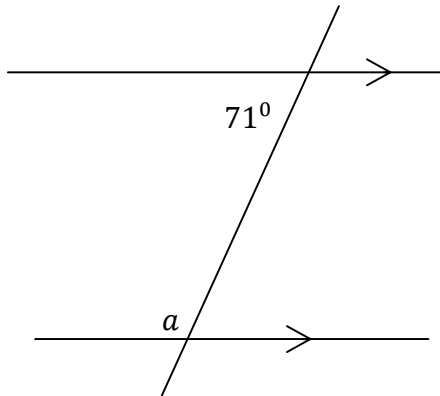

(A) 109°

(B) 71°

(C) 19°

(D) 289°

13) Calculate angle x

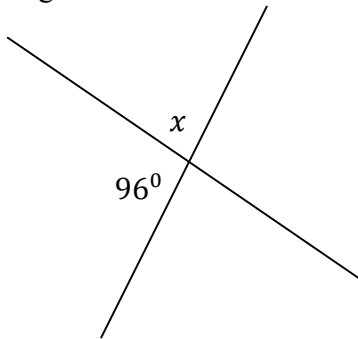

(A) 96°

(B) 71°

(C) 84°

(D) 276°

14) Find angle a

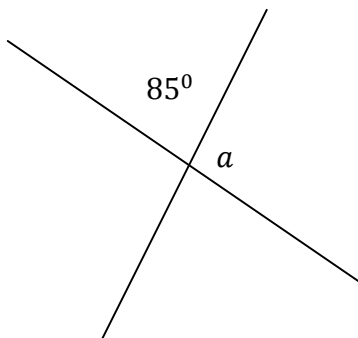

(A) 265°

(B) 85°

(C) 84°

(D) 95°

15) Find the unknown angle.

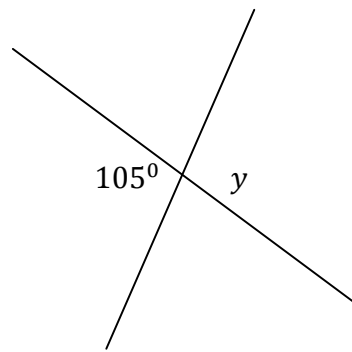

(A) 105°

(B) 180°

(C) 84°

(D) 90°

16)

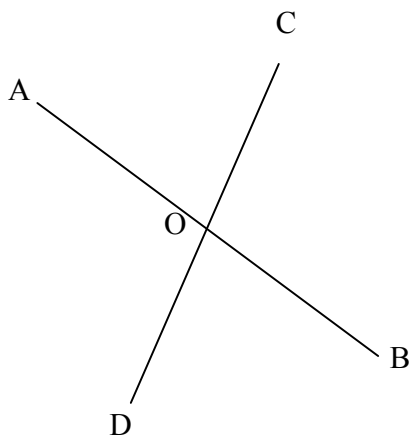

(A) AOD and COB

(B) AOD and AOC

(C) DOB and BOC

(D) DOA and AOC

Which pair of angles are equal?

17) What is angle x

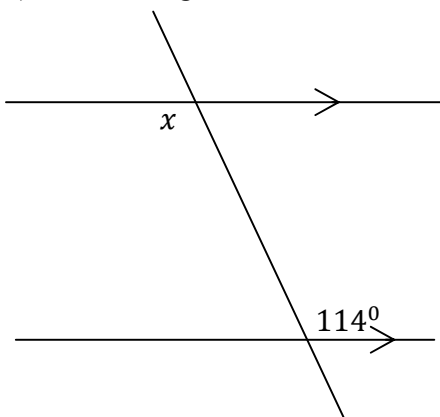

(A) 66°

(B) 180°

(C) 114°

(D) 24°

18) What is the relationship between angles m and n ?

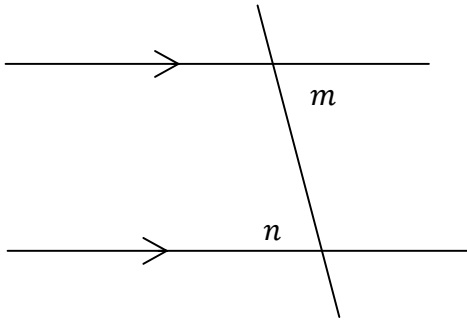

- (A) Corresponding
 (B) Vertically opposite
 (C) Supplementary
 (D) Alternate

19) Find y

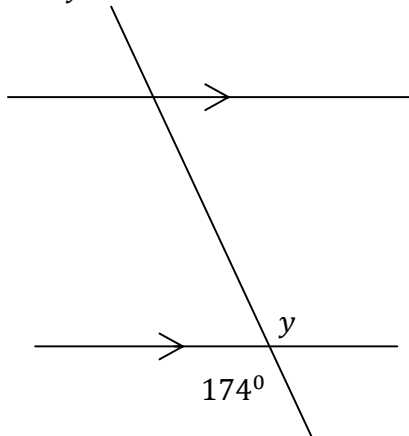

- (A) 6°
 (B) 174°
 (C) 84°
 (D) 24°

20) Find b

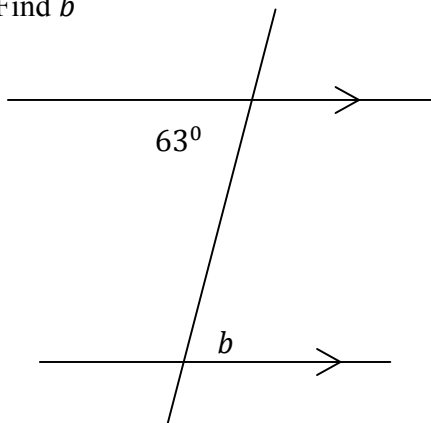

- (A) 63°
 (B) 117°
 (C) 114°
 (D) 27°

TEST 5

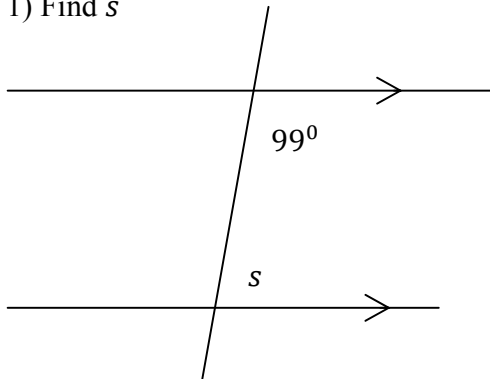
1) Find s 

- (A) 81°
 (B) 189°
 (C) 261°
 (D) 24°

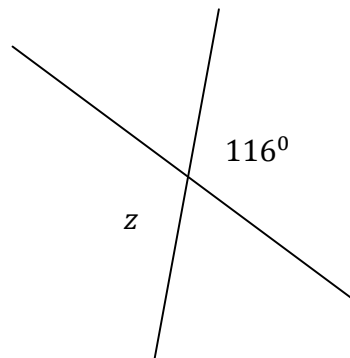
2) What is angle z ?

- (A) 64°
 (B) 180°
 (C) 116°
 (D) 44°

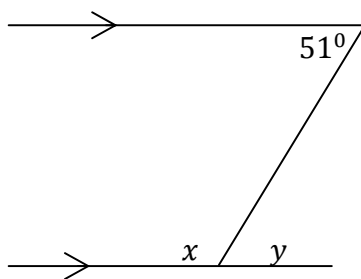
3) x and y are

- (A) 64°
 (B) 129° and 51°
 (C) 116°
 (D) 44°

4)

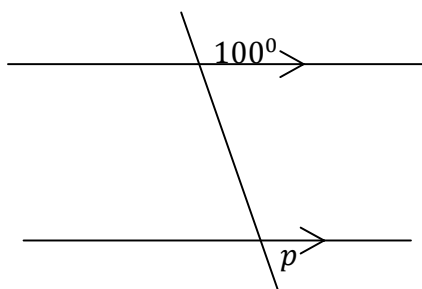
Find angle p .

- (A) 60°
 (B) 100°
 (C) 120°
 (D) 80°

5) Find a and b

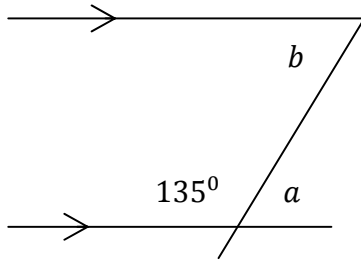

(A) 45° and 135°

(B) 135° and 135°

(C) 45° and 45°

(D) 35° and 45°

6) What is angle a ?

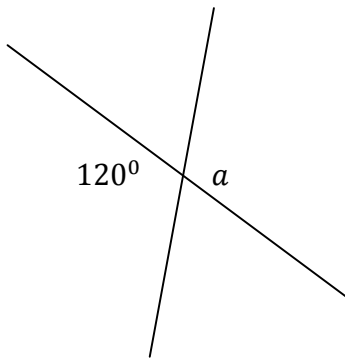

(A) 60°

(B) 100°

(C) 120°

(D) 80°

7) Find the length x

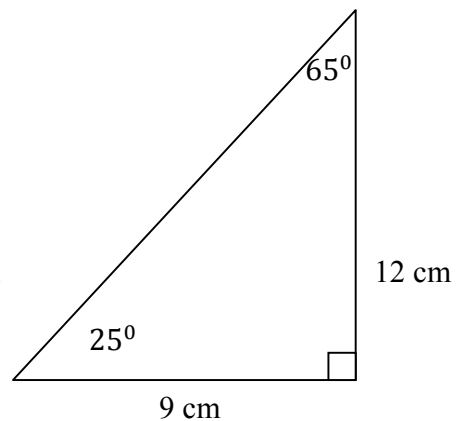
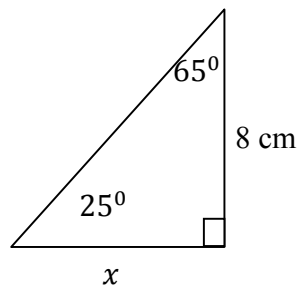

(A) 5 cm

(B) 10 cm

(C) 6 cm

(D) 12 cm

8) Find the length x

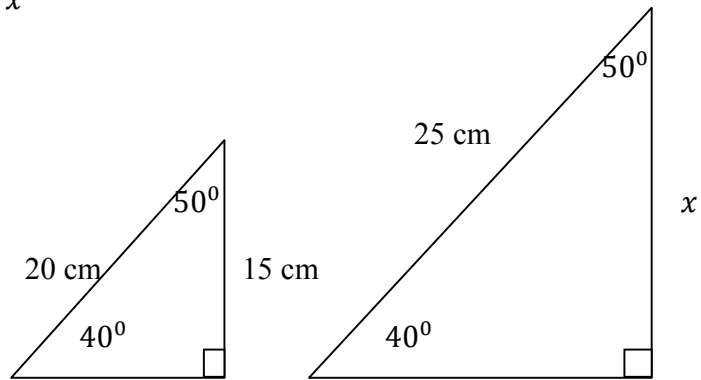

- (A) 20 cm (B) 18.75 cm (C) 22 cm (D) 30 cm

9) Find the length y

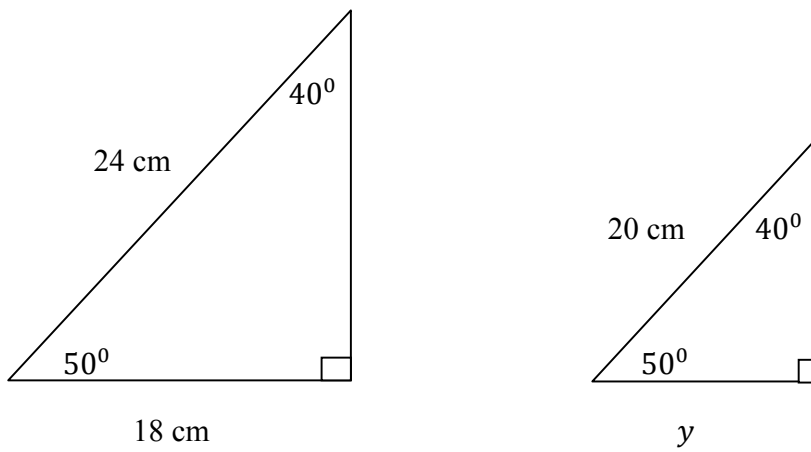

- (A) 15 cm (B) 16 cm (C) 18 cm (D) 20 cm

10) Find the length m

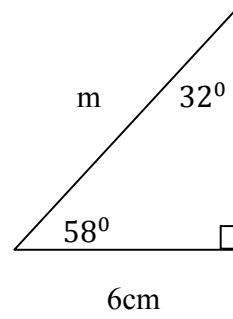
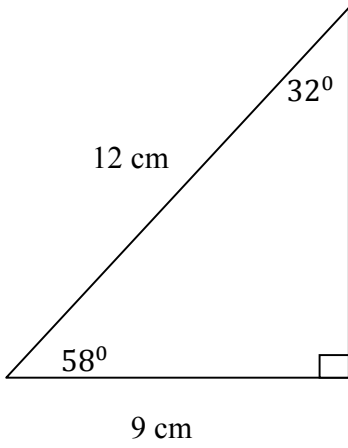

(A) 4 cm

(B) 10 cm

(C) 6 cm

(D) 8 cm

11) What is the value of angle x ?

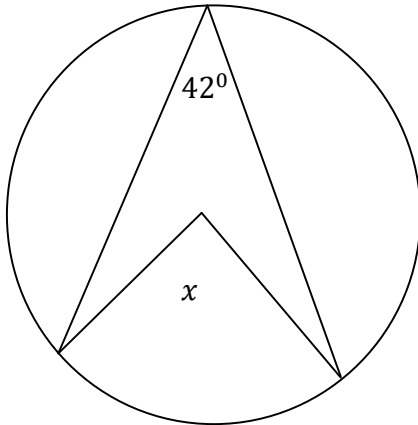

- | |
|-----------------|
| (A) 48° |
| (B) 138° |
| (C) 84° |
| (D) 80° |

12) What is angle a ?

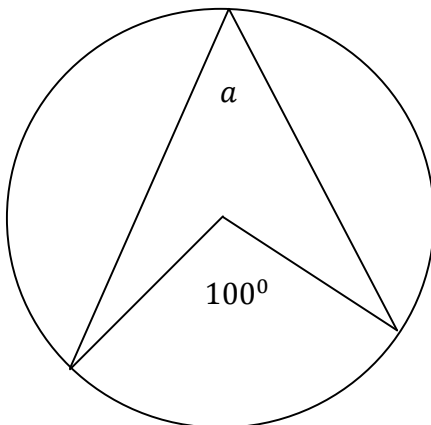

- | |
|----------------|
| (A) 48° |
| (B) 50° |
| (C) 84° |
| (D) 80° |

13) What is angle b ?

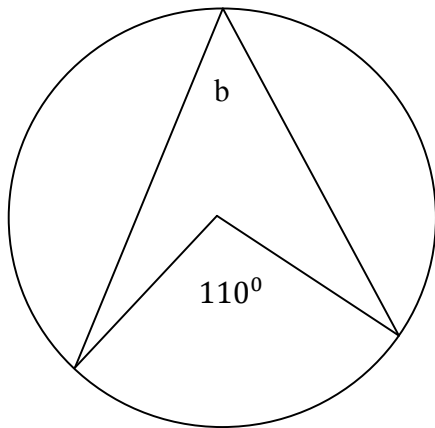

- (A) 55°
 (B) 70°
 (C) 85°
 (D) 80°

14) Find angle c

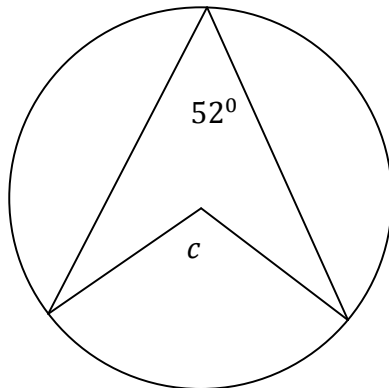

- (A) 128°
 (B) 100°
 (C) 85°
 (D) 104°

15) Find d

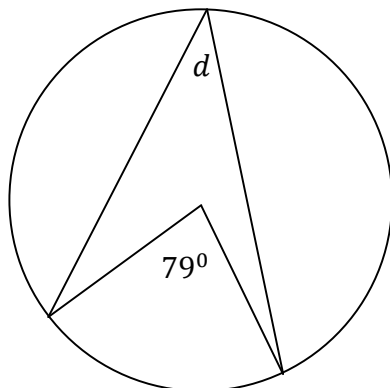

- (A) 101°
 (B) 79°
 (C) 39.5°
 (D) 80°

16) What is the name of a polygon which has an exterior angle of 60° ?

- (A) pentagon (B) hexagon (C) octagon (D) rhombus

17) In which shape do diagonals bisect at 90° ?

- (A) Rhombus (B) Rectangle (C) Triangle (D) Trapezium

18) When the interior angles of a polygon is added, the sum is 360° . What is the name of this polygon?

- (A) Triangle (B) Hexagon (C) Pentagon (D) Quadrilateral

19) What is the sum of the interior angles of a triangle?

- (A) 360° (B) 270° (C) 180° (D) 90°

20) What is the sum of the interior angles of any quadrilateral?

- (A) 360° (B) 270° (C) 180° (D) 90°

TEST 6

1) Reflect the line in the x-axis. Draw its image?

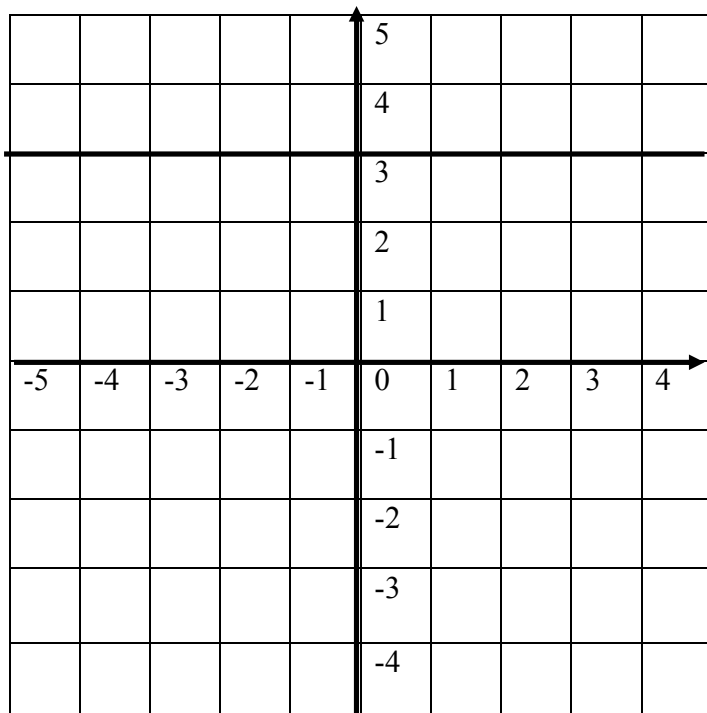

2) Reflect the line in the y-axis. Draw its image.

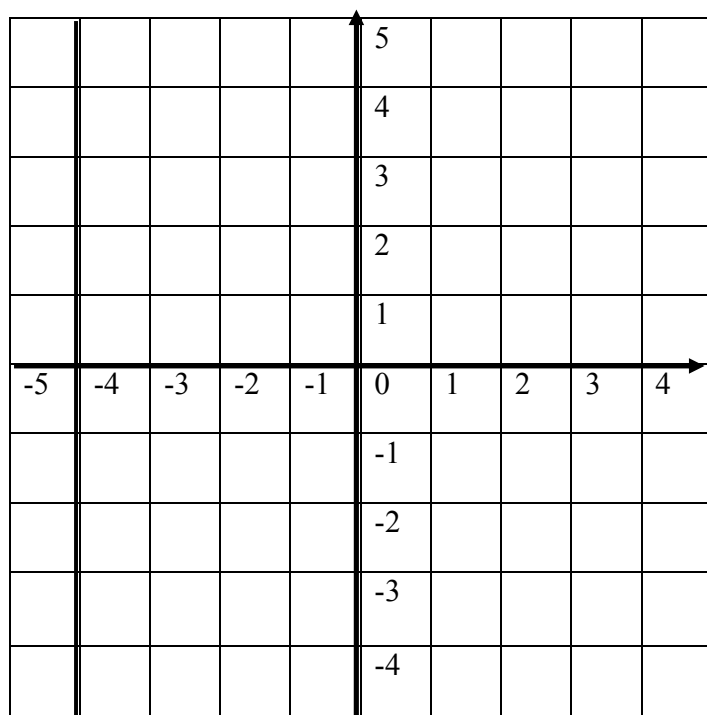

3) Draw the reflection of the triangle in the x-axis.

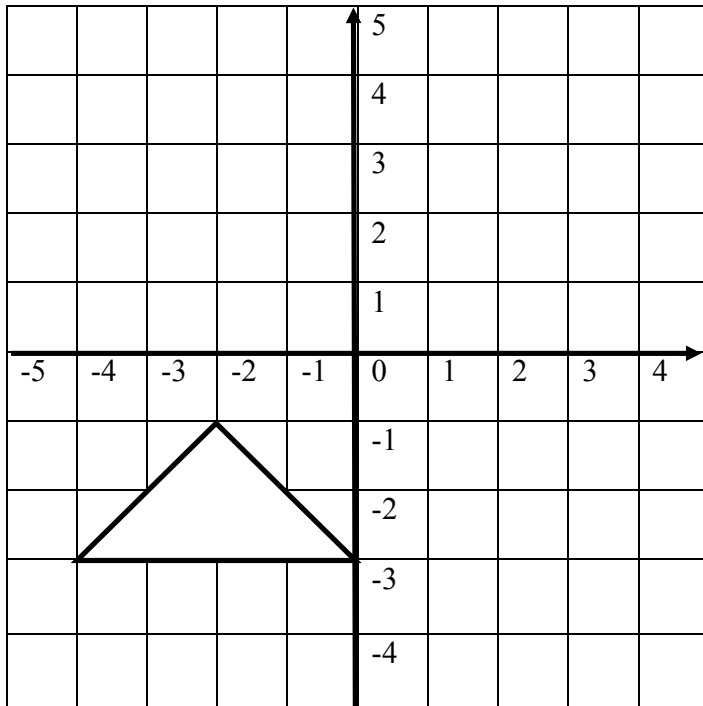

4) Draw the reflection of the square in the y-axis.

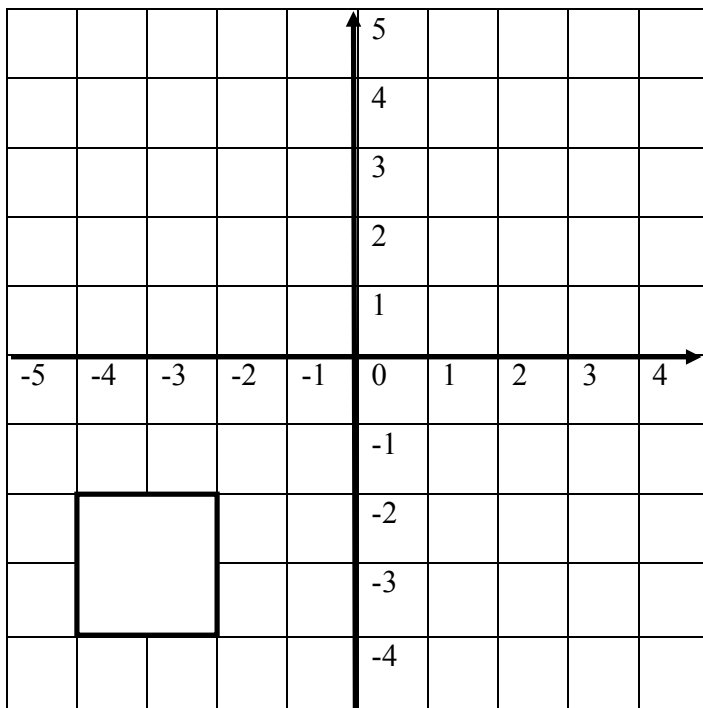

5) Which statement is true about the objects and their images?

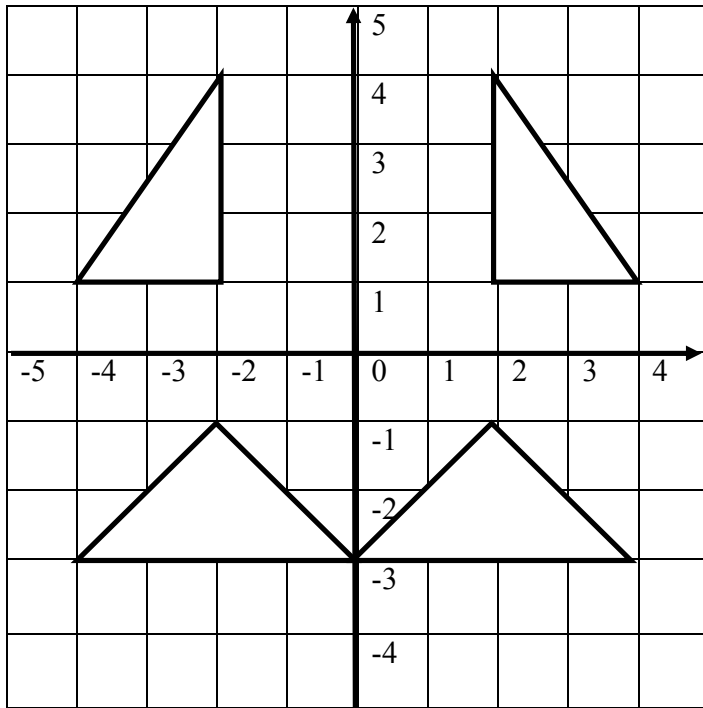

- (A) Objects are the same size and same shape as their images.
- (B) Objects are different in size and shape from their image.
- (C) Objects are bigger than their images.
- (D) Objects are smaller than their images.

6) Which diagram shows a reflection in the y-axis?

<p>(A)</p>	<p>(B)</p>
<p>(C)</p>	<p>(D)</p>

7) Which transformation took place in the diagram?

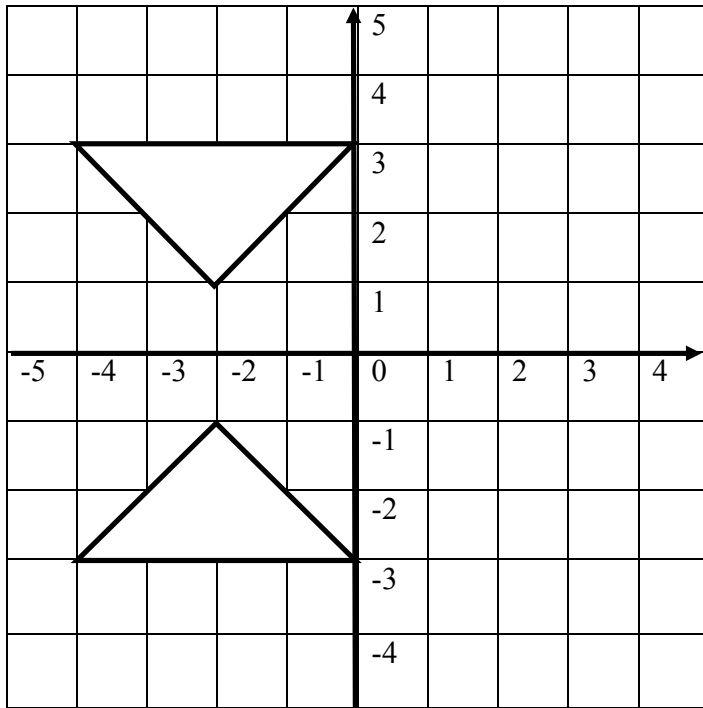

- (A) A rotation
 (B) An enlargement
 (C) A translation
 (D) A reflection

8) A translation vector moves LM to $L'M'$. Which one is the translation vector?

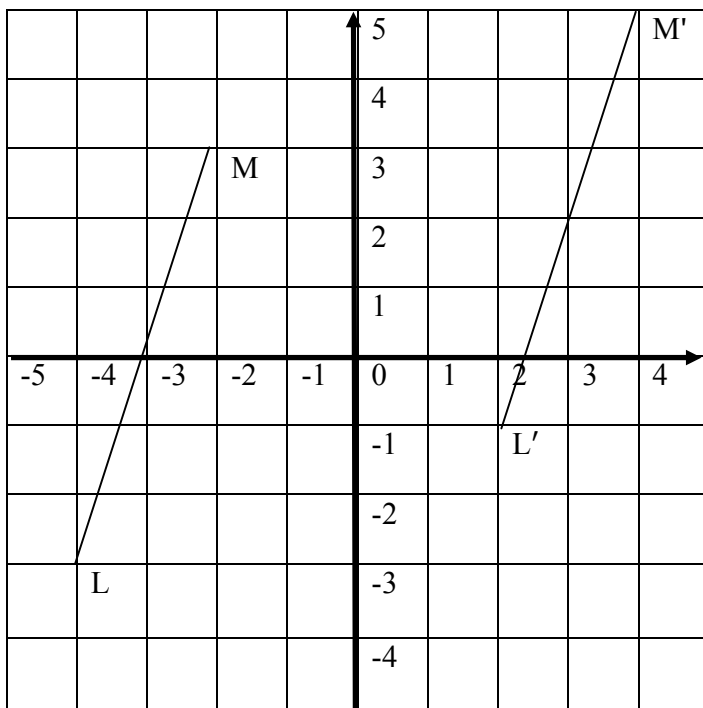

- (A) $\begin{pmatrix} 6 \\ 3 \end{pmatrix}$
 (B) $\begin{pmatrix} 6 \\ 2 \end{pmatrix}$
 (C) $\begin{pmatrix} -6 \\ -2 \end{pmatrix}$
 (D) $\begin{pmatrix} 6 \\ -2 \end{pmatrix}$

9) Which translation vector moved the object?

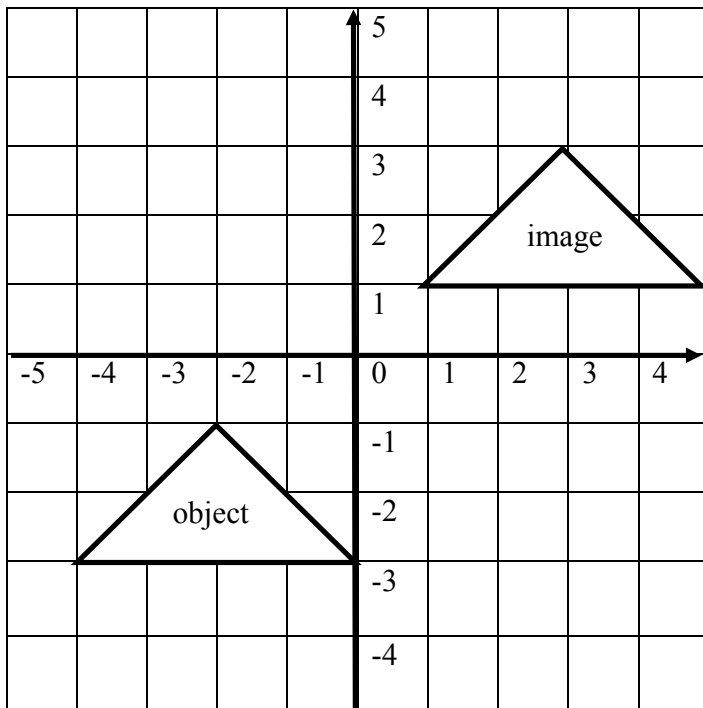

(A) $\begin{pmatrix} 5 \\ 4 \end{pmatrix}$

(B) $\begin{pmatrix} -5 \\ -4 \end{pmatrix}$

(C) $\begin{pmatrix} 4 \\ 3 \end{pmatrix}$

(D) $\begin{pmatrix} -4 \\ -3 \end{pmatrix}$

10) Which translation vector is responsible for the movement?

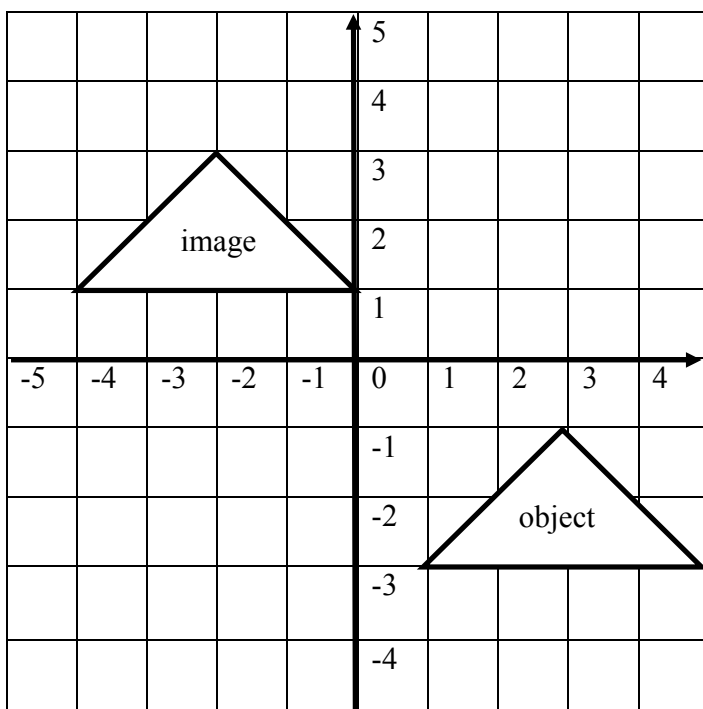

(A) $\begin{pmatrix} 5 \\ 4 \end{pmatrix}$

(B) $\begin{pmatrix} -5 \\ 4 \end{pmatrix}$

(C) $\begin{pmatrix} 4 \\ 3 \end{pmatrix}$

(D) $\begin{pmatrix} -4 \\ -3 \end{pmatrix}$

11) Which translation vector is correct?

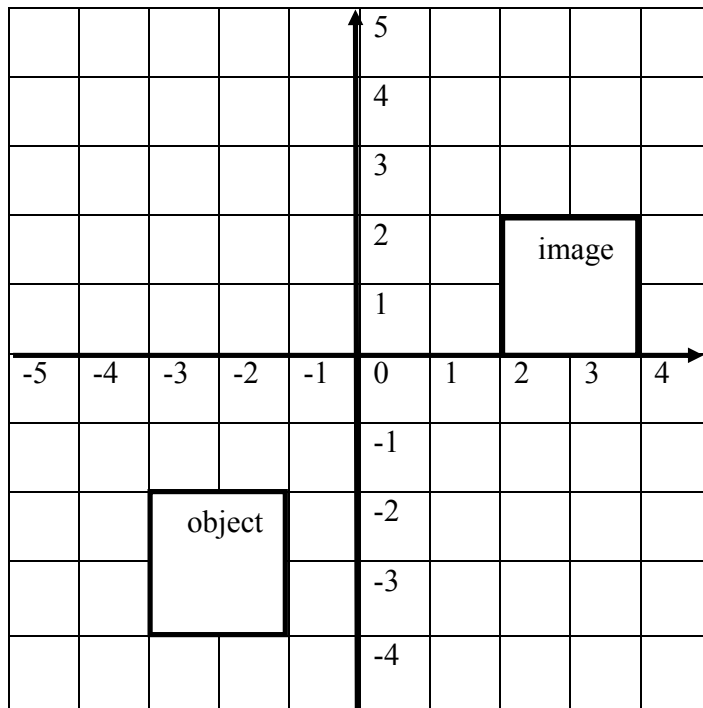

(A) $\begin{pmatrix} 5 \\ 4 \end{pmatrix}$

(B) $\begin{pmatrix} -5 \\ -4 \end{pmatrix}$

(C) $\begin{pmatrix} 4 \\ 3 \end{pmatrix}$

(D) $\begin{pmatrix} -4 \\ -3 \end{pmatrix}$

12) A(3, 4) is mapped onto A'(-3, -2). Find the translation vector.

(A) $\begin{pmatrix} 6 \\ 6 \end{pmatrix}$

(B) $\begin{pmatrix} 0 \\ 2 \end{pmatrix}$

(C) $\begin{pmatrix} -6 \\ -6 \end{pmatrix}$

(D) $\begin{pmatrix} 6 \\ 5 \end{pmatrix}$

13) B(-2, 5) is mapped onto B'(4, 1). Find the translation vector.

(A) $\begin{pmatrix} 6 \\ 6 \end{pmatrix}$

(B) $\begin{pmatrix} 6 \\ 4 \end{pmatrix}$

(C) $\begin{pmatrix} -6 \\ -6 \end{pmatrix}$

(D) $\begin{pmatrix} 6 \\ -4 \end{pmatrix}$

14) Under a translation, C(6, -3) is mapped onto C'((2, 3). What is the translation vector?

(A) $\begin{pmatrix} 4 \\ 6 \end{pmatrix}$

(B) $\begin{pmatrix} -4 \\ 6 \end{pmatrix}$

(C) $\begin{pmatrix} -6 \\ -6 \end{pmatrix}$

(D) $\begin{pmatrix} 6 \\ 4 \end{pmatrix}$

15) An object $D(-2, -4)$ is mapped onto $D'(2, 3)$. Which translation vector was responsible for this?

- (A) $\begin{pmatrix} 4 \\ 7 \end{pmatrix}$ (B) $\begin{pmatrix} -4 \\ -7 \end{pmatrix}$ (C) $\begin{pmatrix} 7 \\ 4 \end{pmatrix}$ (D) $\begin{pmatrix} -7 \\ 4 \end{pmatrix}$

16) Find the translation vector when $E(2, 4)$ is mapped onto $E'(5, 6)$.

- (A) $\begin{pmatrix} 2 \\ 3 \end{pmatrix}$ (B) $\begin{pmatrix} -3 \\ -2 \end{pmatrix}$ (C) $\begin{pmatrix} 7 \\ 10 \end{pmatrix}$ (D) $\begin{pmatrix} 3 \\ 2 \end{pmatrix}$

17) Find the translation vector that maps $F(5, 7)$ onto $F'(8, 10)$.

- (A) $\begin{pmatrix} -3 \\ -3 \end{pmatrix}$ (B) $\begin{pmatrix} 13 \\ 17 \end{pmatrix}$ (C) $\begin{pmatrix} 3 \\ 3 \end{pmatrix}$ (D) $\begin{pmatrix} 6 \\ 5 \end{pmatrix}$

18) Find the translation vector that maps $G(4, 5)$ onto $G'(8, 7)$.

- (A) $\begin{pmatrix} 2 \\ 4 \end{pmatrix}$ (B) $\begin{pmatrix} 4 \\ 2 \end{pmatrix}$ (C) $\begin{pmatrix} -4 \\ -2 \end{pmatrix}$ (D) $\begin{pmatrix} 12 \\ 12 \end{pmatrix}$

19) Which translation vector maps $H(1, 1)$ onto $H'(3, 4)$?

- (A) $\begin{pmatrix} 2 \\ 3 \end{pmatrix}$ (B) $\begin{pmatrix} -2 \\ -3 \end{pmatrix}$ (C) $\begin{pmatrix} 4 \\ 5 \end{pmatrix}$ (D) $\begin{pmatrix} -3 \\ -2 \end{pmatrix}$

20) Which translation vector maps $I(-1, -2)$ onto $I'(2, 4)$?

- (A) $\begin{pmatrix} -3 \\ -6 \end{pmatrix}$ (B) $\begin{pmatrix} 1 \\ 2 \end{pmatrix}$ (C) $\begin{pmatrix} -1 \\ -2 \end{pmatrix}$ (D) $\begin{pmatrix} 3 \\ 6 \end{pmatrix}$

TEST 7

1) What is the scale factor of the enlargement?

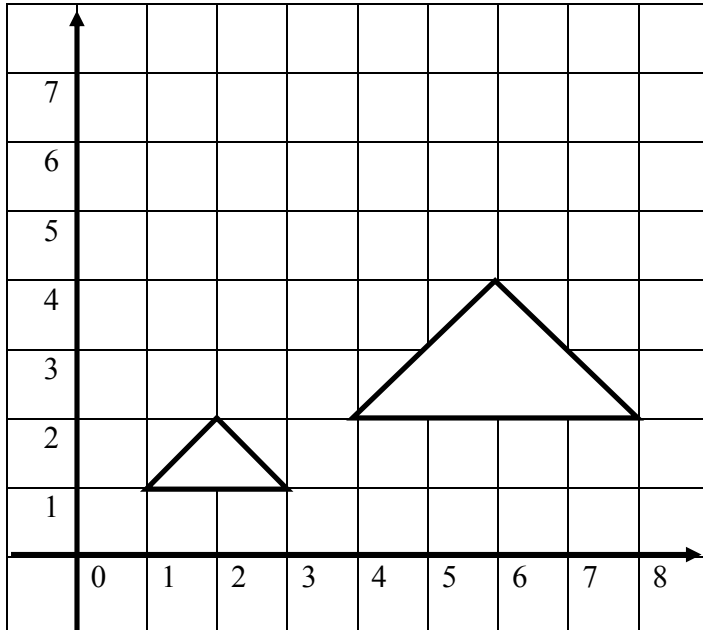

(A) 1

(B) 2

(C) 3

(D) 4

2) What is the scale factor of the enlargement?

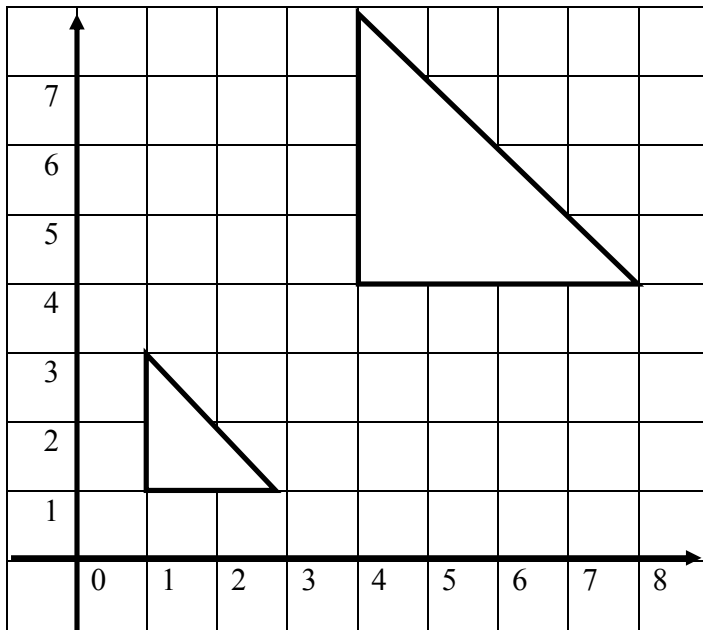

(A) 1

(B) 2

(C) 3

(D) 4

3) What is the scale factor of the enlargement?

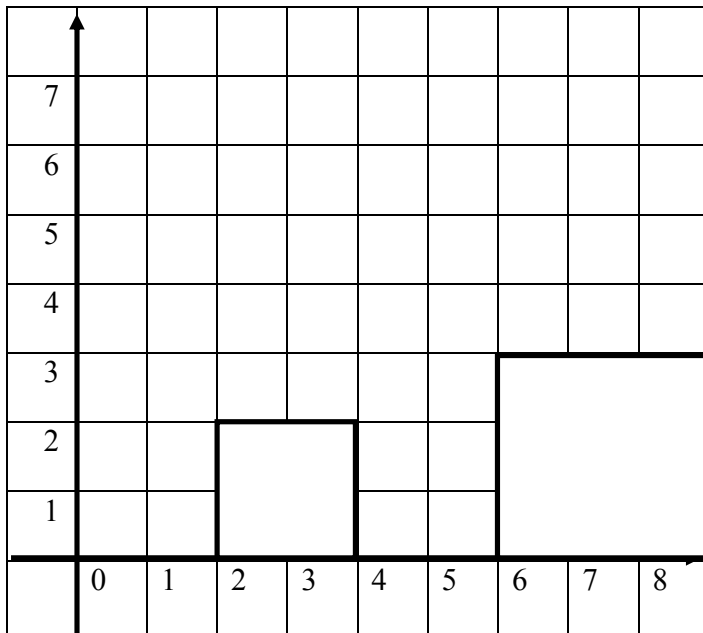

(A) 1.5

(B) 2

(C) 3

(D) 4

4) What is the scale factor of the enlargement?

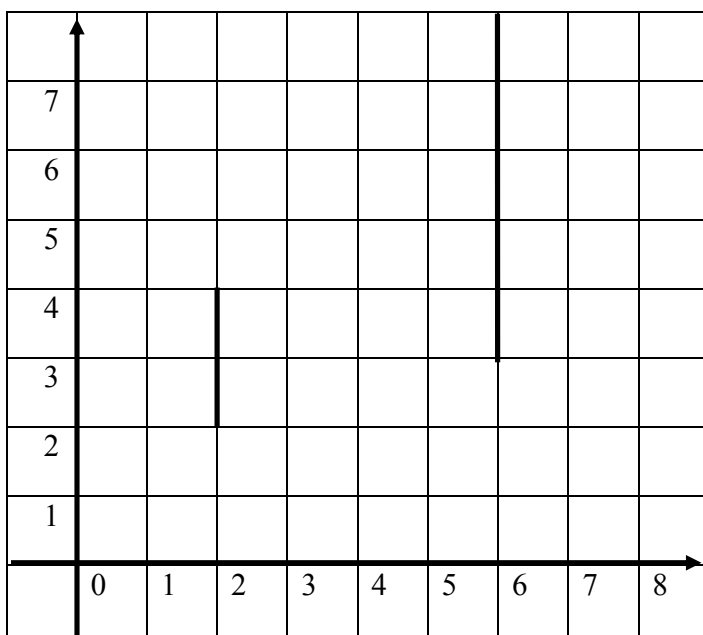

(A) 1

(B) 2.5

(C) 3

(D) 4

5) By drawing lines, find the center of enlargement

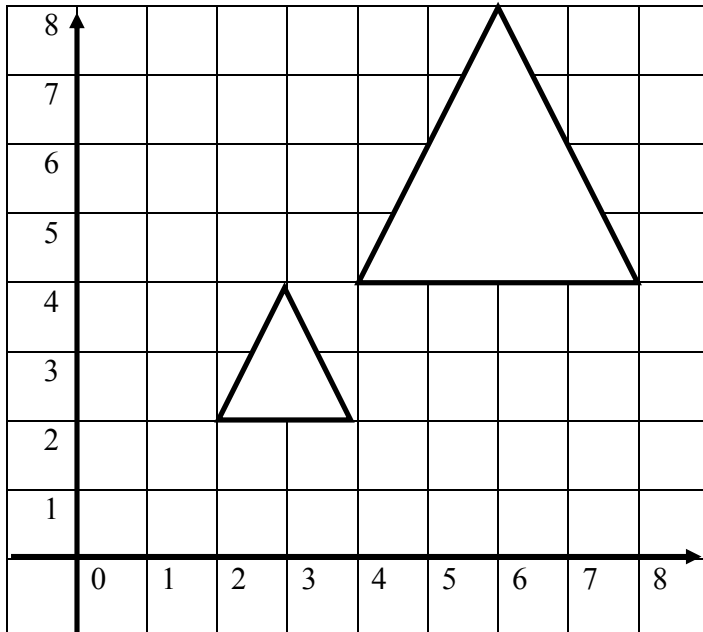

6) By drawing lines, find the center of enlargement.

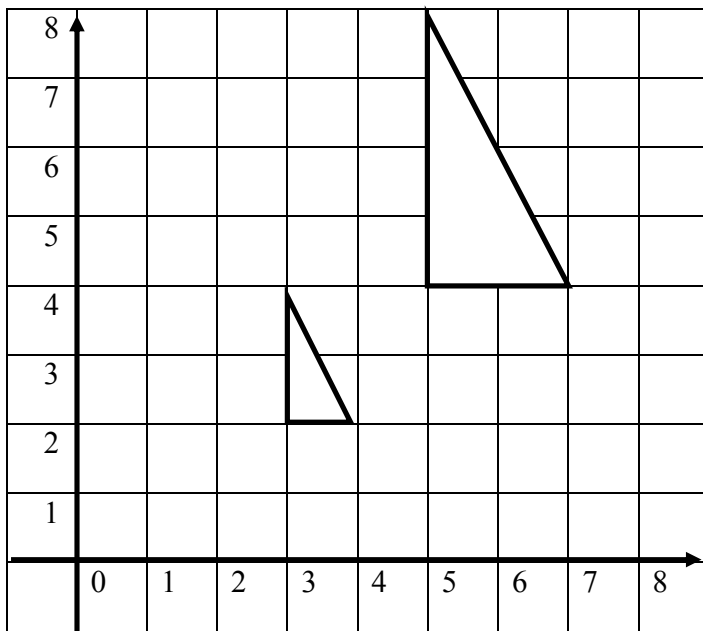

7) By drawing lines, find the center of enlargement.

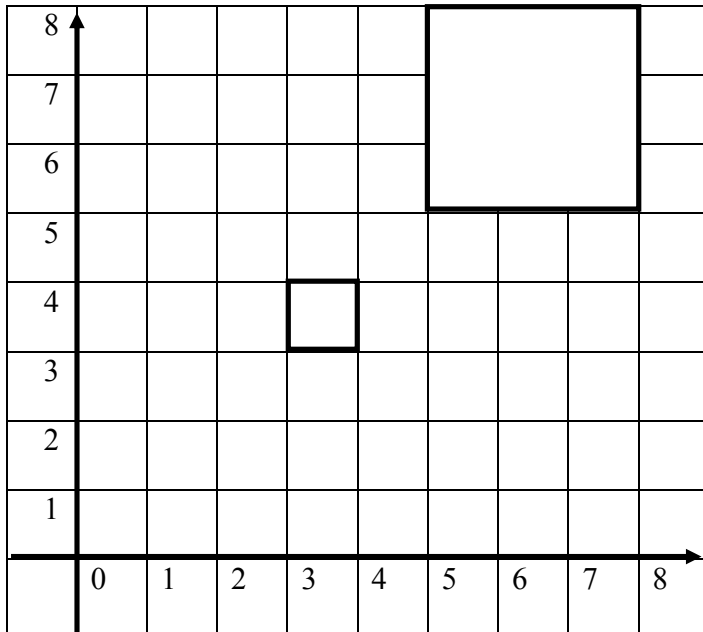

8) By drawing lines, find the center of enlargement.

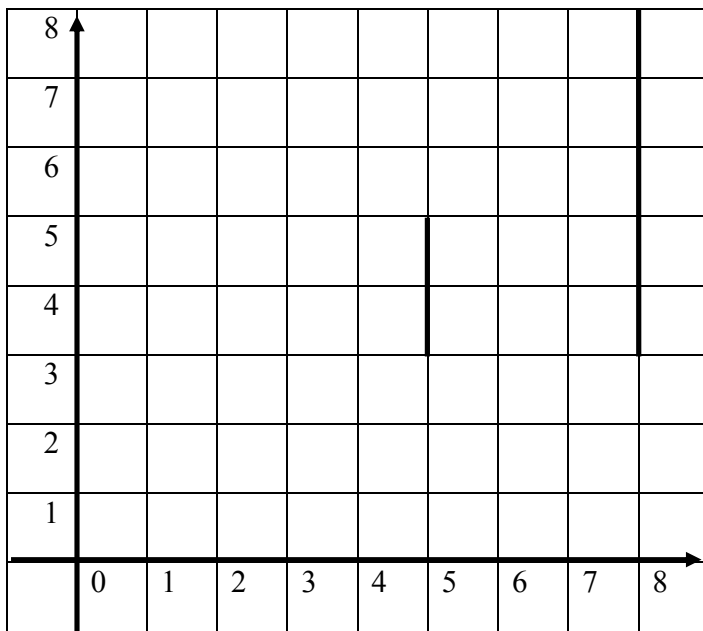

9) Which diagram is a clockwise rotation of 90° about the origin.

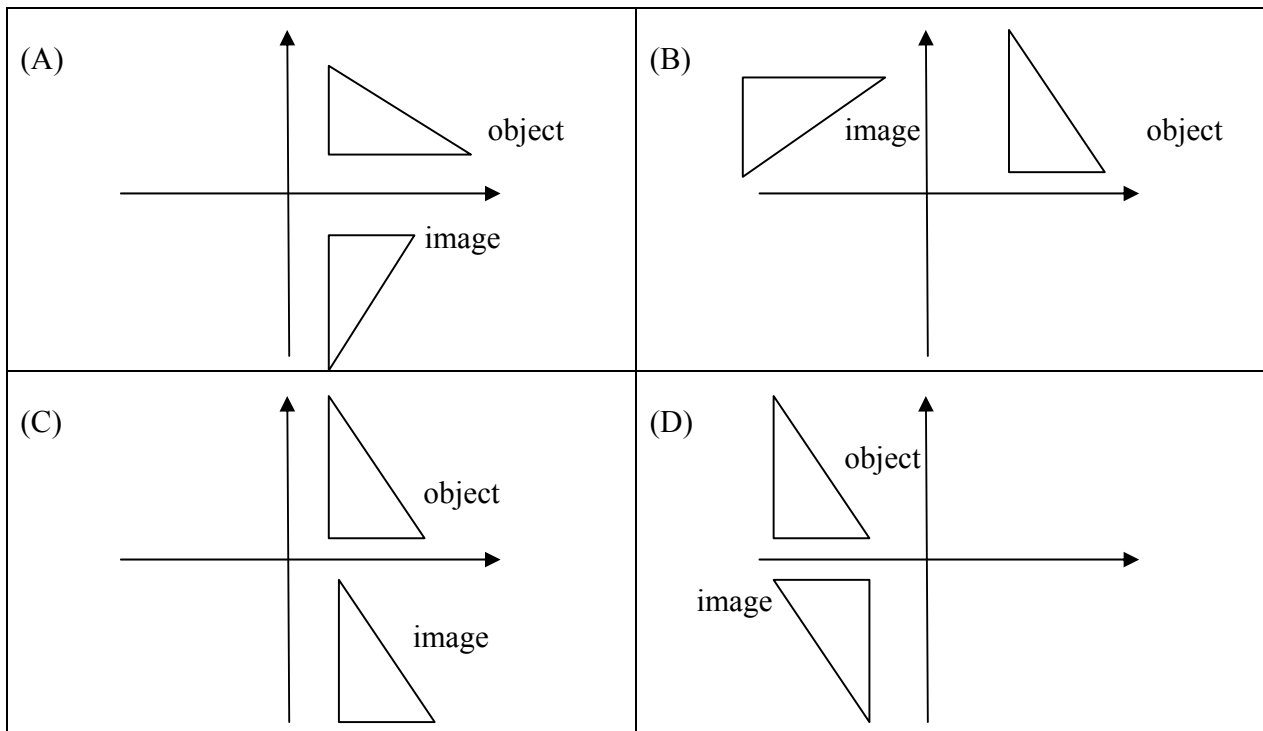

10) Which diagram is an anticlockwise rotation of 90° about the origin.

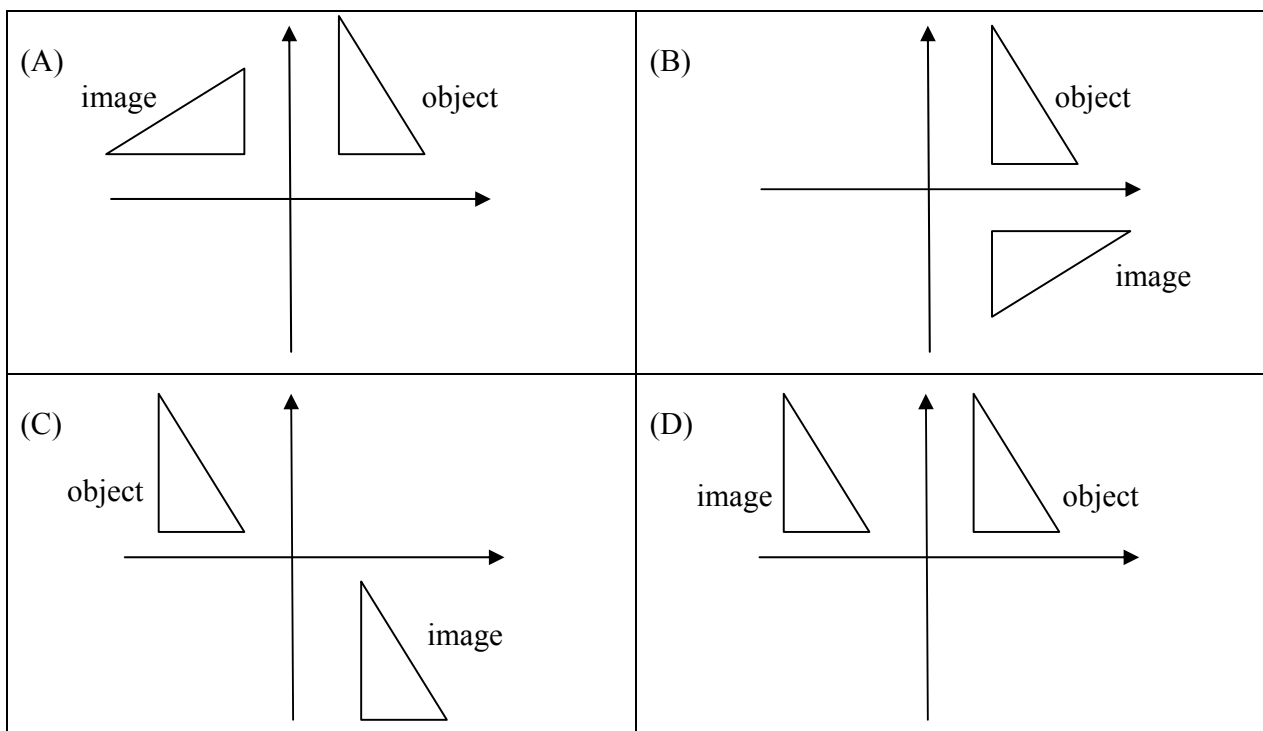

11) Which diagram is a clockwise rotation of 90° about the origin.

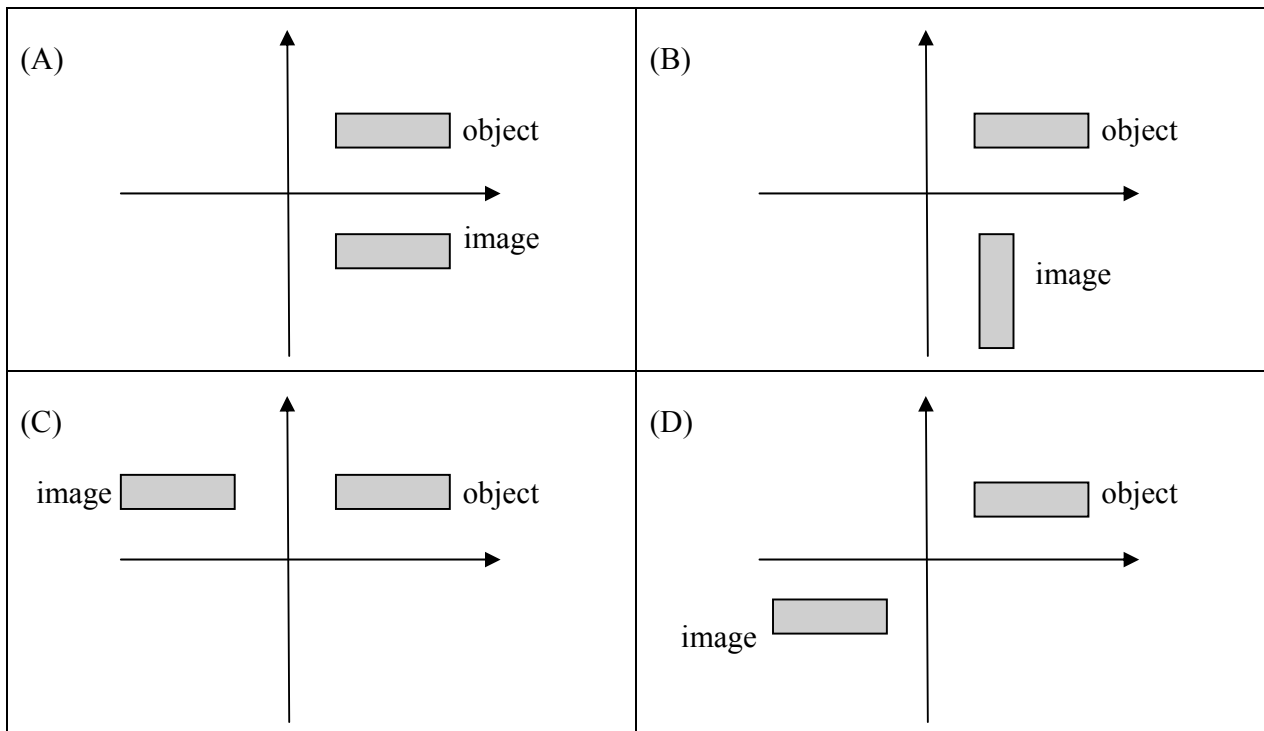

12) Which diagram is an anticlockwise rotation of 90° about the origin.

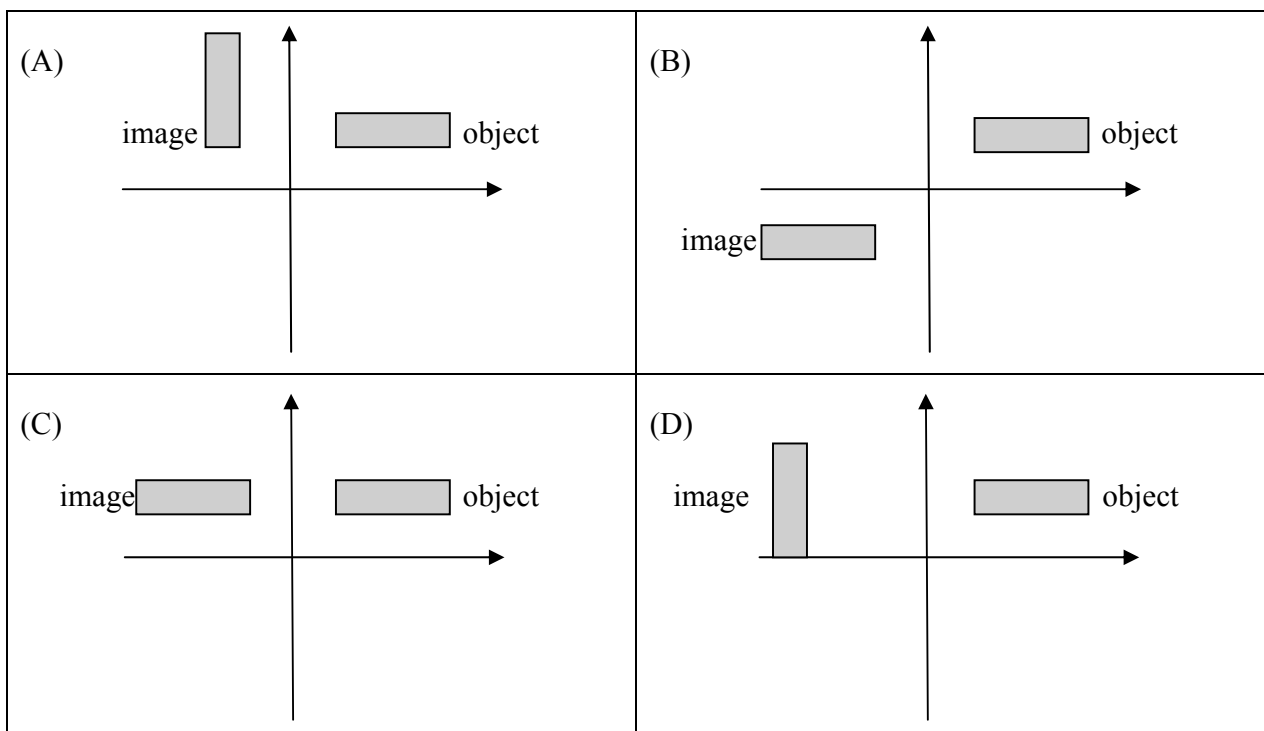

13) Which diagram is a clockwise rotation of 180° about the origin.

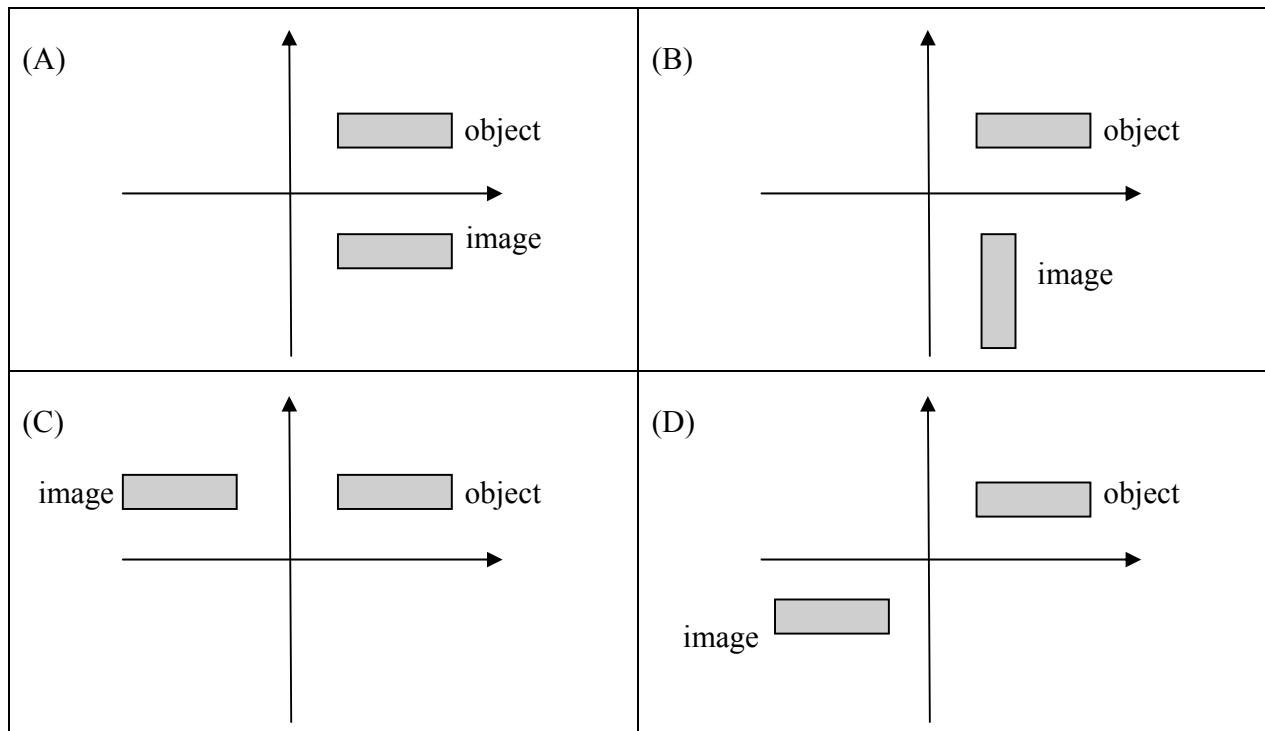

14) Which diagram is an anticlockwise rotation of 180° about the origin.

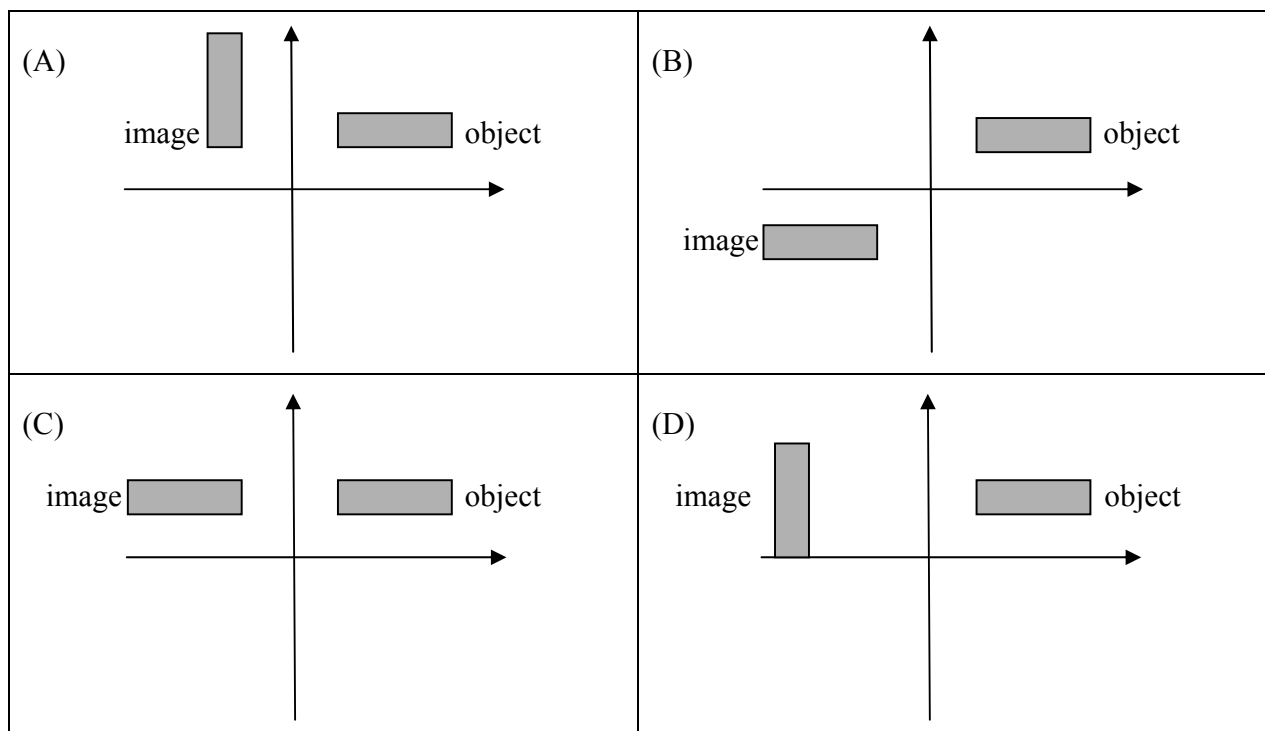

15) Rotate the line through 90° in a clockwise direction. Use the origin as the center of rotation.

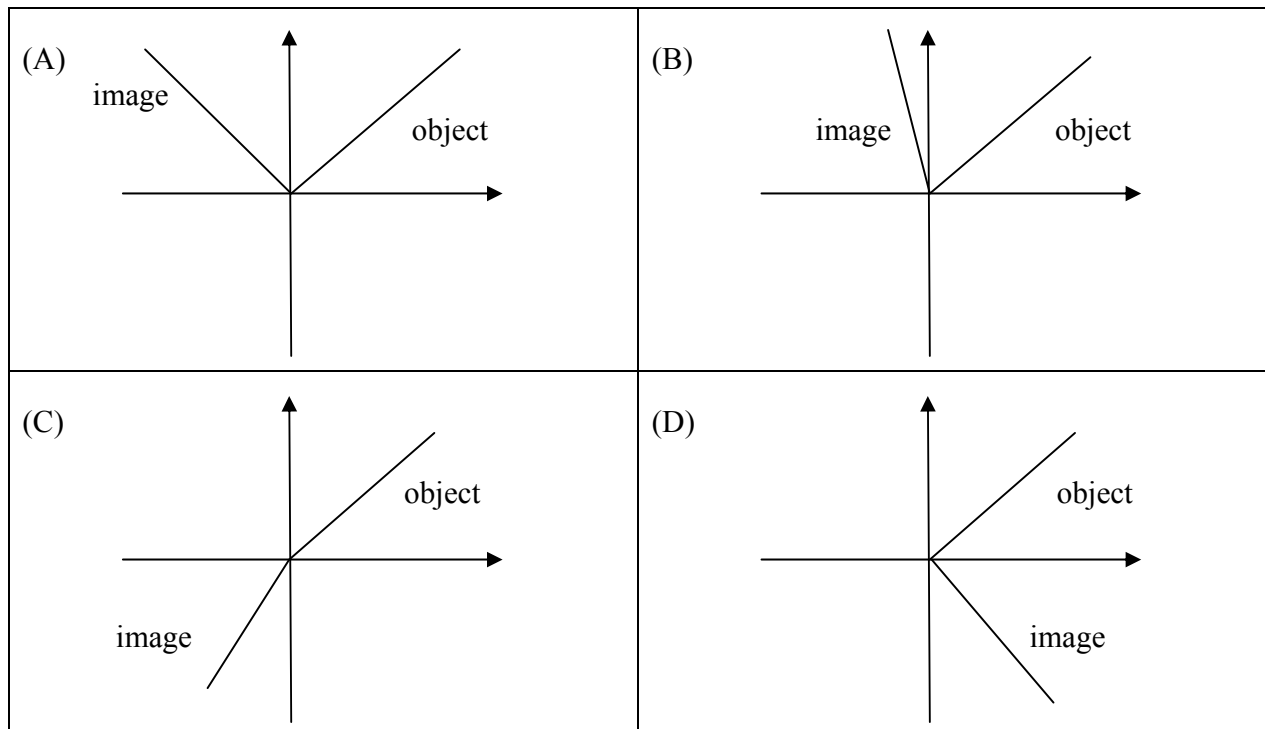

16) Rotate the line through 90° in an anticlockwise direction. Use the origin as the center of rotation.

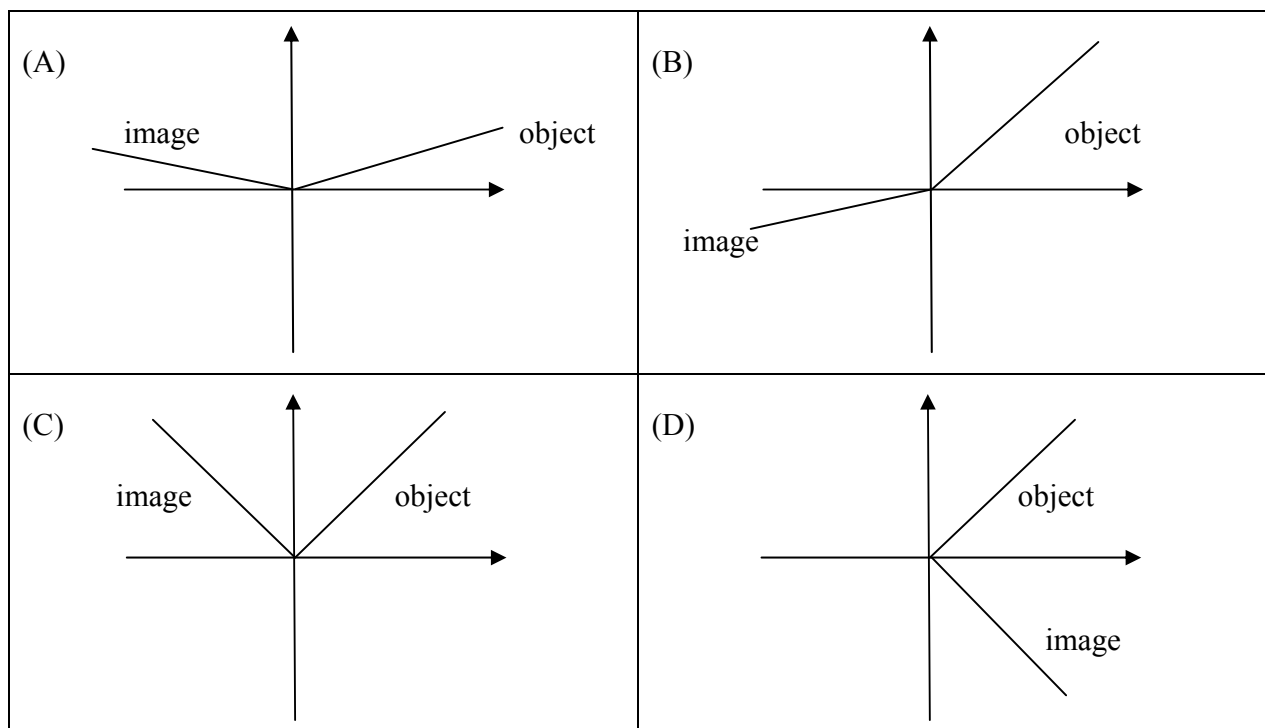

17) Draw the image of the line when it is rotated 90° in a clockwise direction.

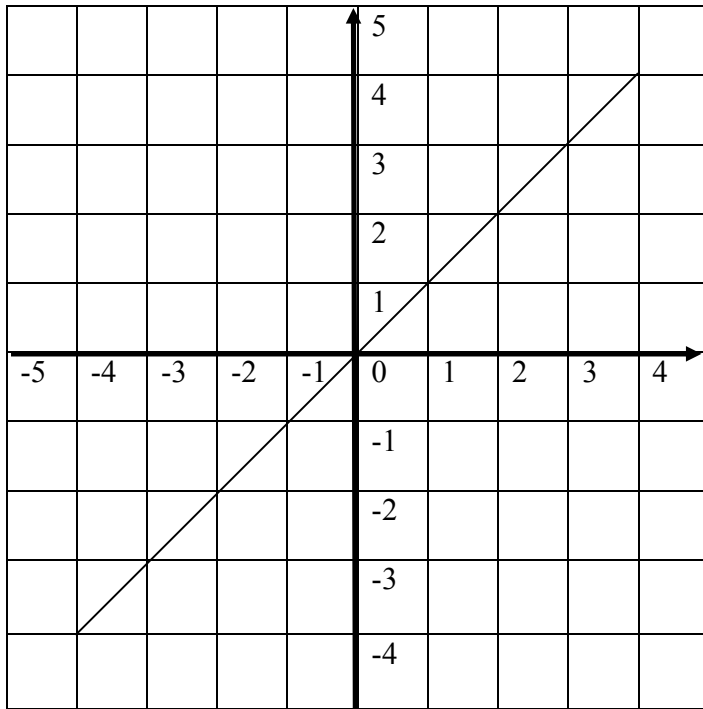

18) Draw the image of the line when it is rotated 90° in an anticlockwise direction.

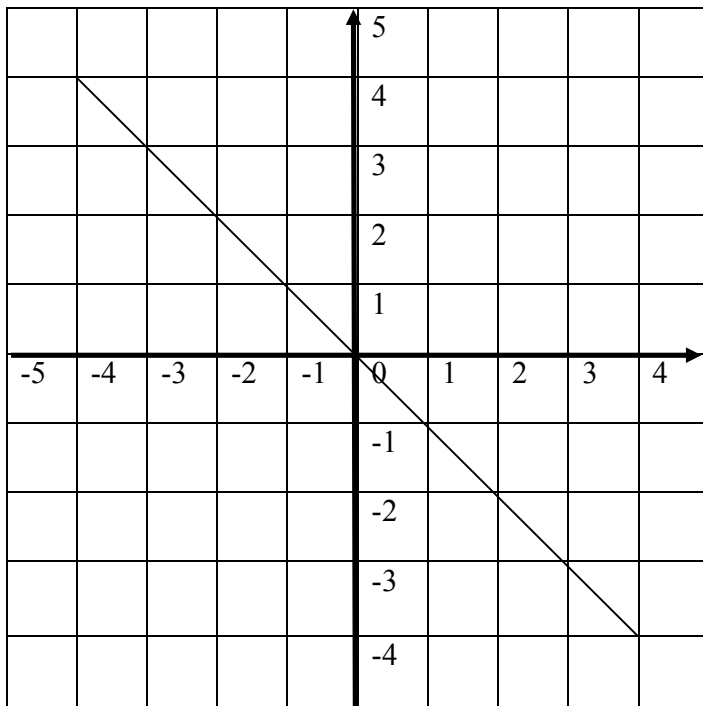

19) Draw the image of the line when it is rotated 45° in a clockwise direction.

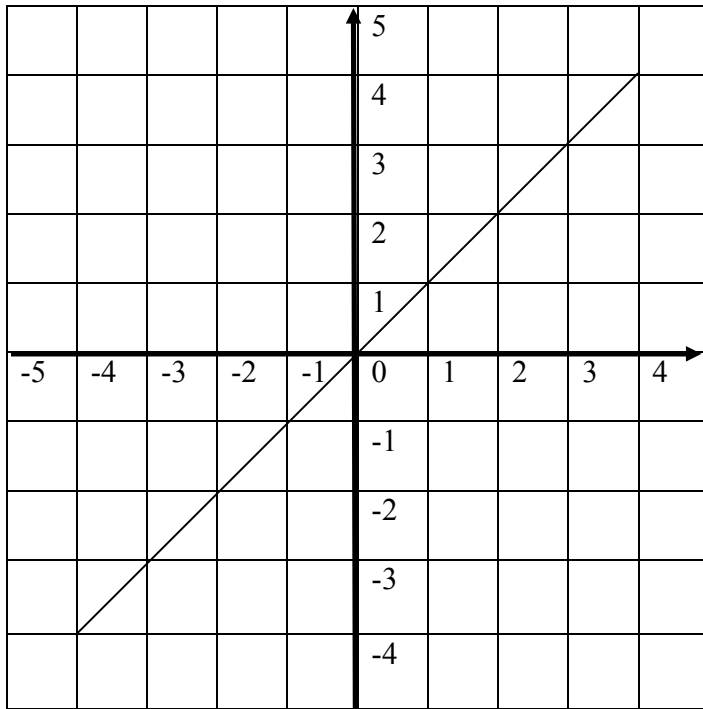

20) Draw the image of the line when it is rotated 45° in an anticlockwise direction.

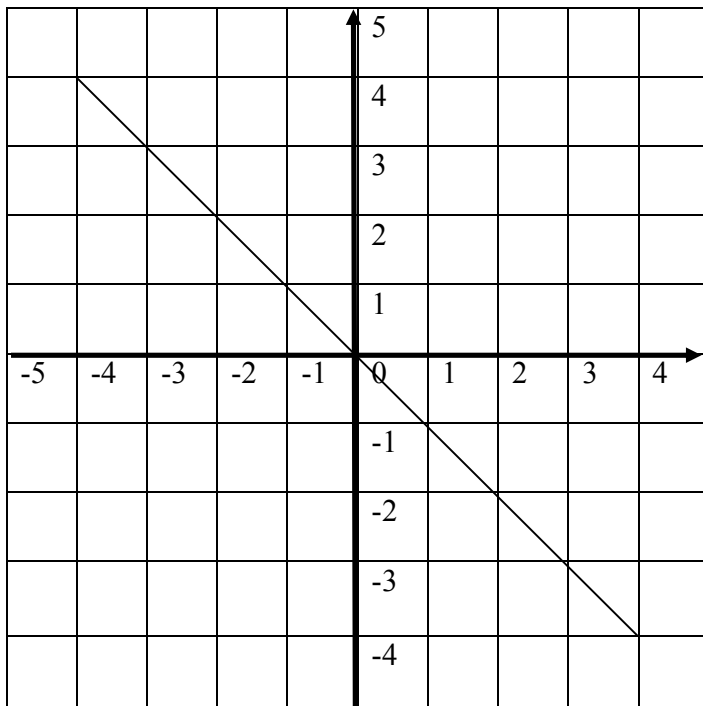

TEST 8

State the kind of transformation.

1)

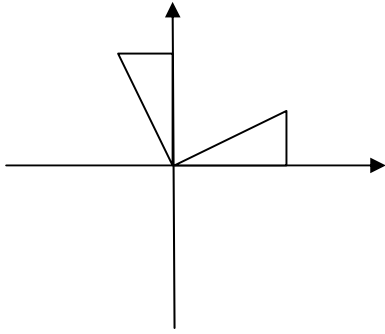

2)

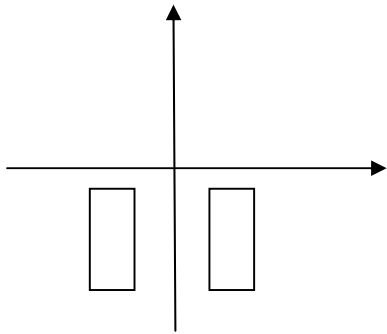

3)

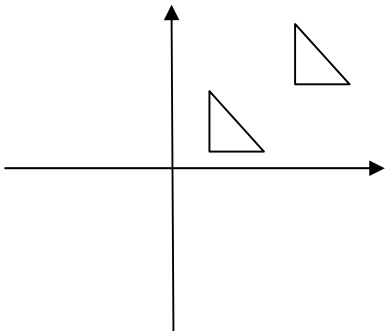

4)

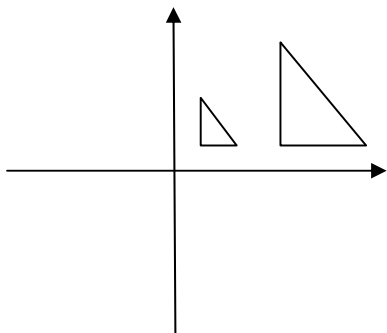

State the kind of transformation.

5)

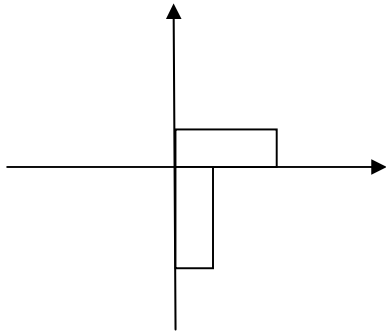

6)

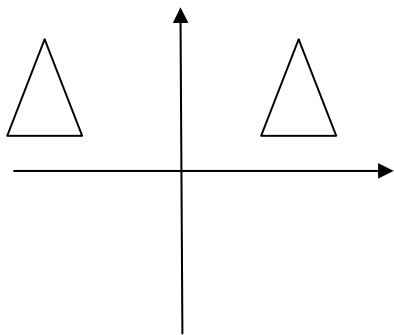

7)

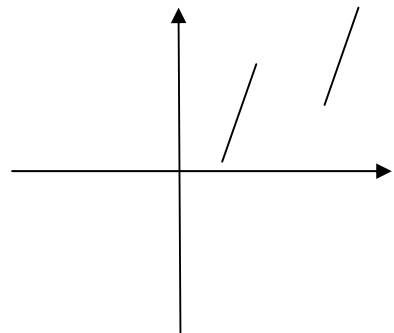

8)

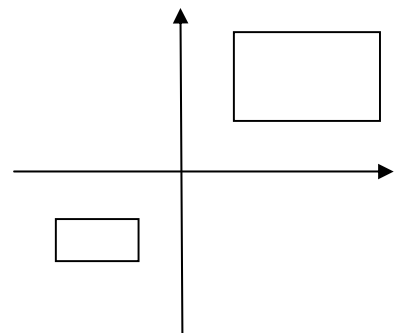

State the kind of transformation.

9)

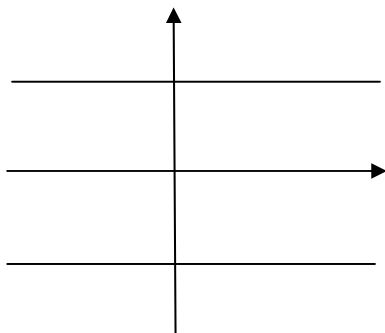

10)

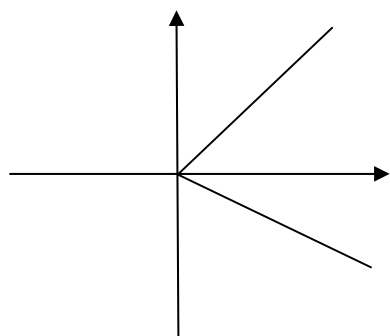

11)

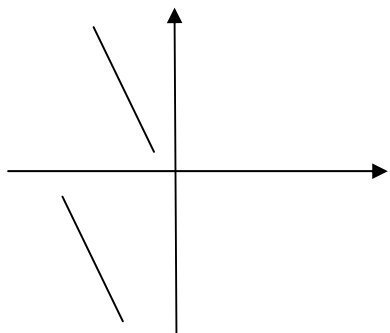

12)

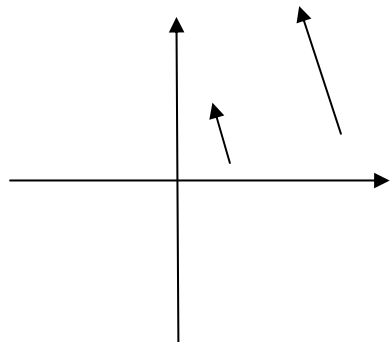

13) Define transformation.

- (A) A transformation is when a point or an object makes a turn, a flip, a slide or is resized on the Cartesian plane.
- (B) A transformation is a process on the Cartesian plane.
- (C) This is done with geometrical instruments.
- (D) This is when students do not pay attention to a Teacher.

14) What is a reflection?

- (A) A reflection is when a student thinks about his/her future.
- (B) A reflection is a mirror image of a point or a shape on the Cartesian plane.
- (C) This happens to students when they get CSEC results in August.
- (D) This is when a mirror is drawn on the Cartesian plane.

15) What is a rotation?

- (A) A rotation is when a student uses a protractor on a graph page.
- (B) This is when a student cuts a line with a pair of compasses on the Cartesian plane.
- (C) This happens when a student sees the Principal and immediately turns around and does a matrix.
- (D) A rotation is when a point or an object is turned about a fixed point called the center of rotation on the Cartesian plane.

16) What is an enlargement?

- (A) An enlargement happens when a student draws a larger shape.
- (B) This happens to the cookies when they are baked in the Home Economics room.
- (C) An enlargement is when a point or an object is made larger or smaller on the Cartesian plane.
- (D) This occurs when a student draws a larger line with a ruler.

17) What is a translation?

(A) A translation is the movement of a point or a shape from one position to another on the Cartesian plane.

(A) This happens when a student uses a mirror line on an object.

(C) A translation is when a student buys an item at the School's cafeteria and receives extra change.

(D) A translation takes place on the Cartesian plane.

18) What is a translation vector?

(A) A translation vector is when an object is moved on the Cartesian plane.

(B) This is when students hit the ball when they play volleyball during Physical Education class.

(C) A translation vector is drawn with a ruler and pencil.

(D) A translation vector is a vector that moves a point or an object during a translation on the Cartesian plane.

19) Which is the translation formula?

(A) $Image = Point - Translation\ vector$

(B) $Image = Point + Translation\ vector$

(C) $y = mx + c$

(D) $y = mx - c$

20) What is the origin?

(A) This was when Mathematics was invented in old civilisations.

(B) The origin was when Pythagoras formulated a theorem for right angled triangles.

(C) This is the point (0, 0) on the Cartesian plane.

(D) The origin is the mirror image of any given point on the Cartesian plane.

TEST 9

Mixed Questions

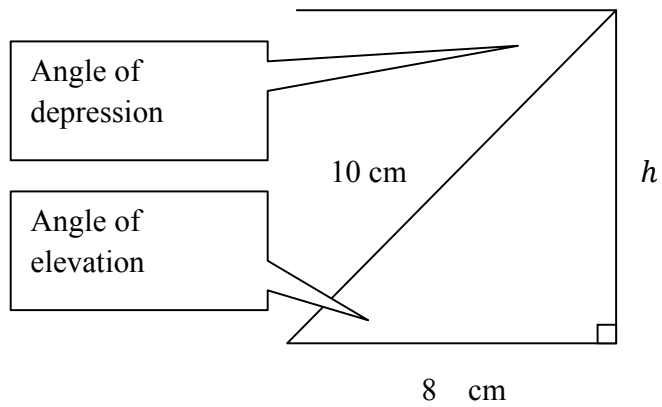
1) Calculate h 

- (A) 4 cm (B) 9 cm (C) 6 cm (D) 12 cm

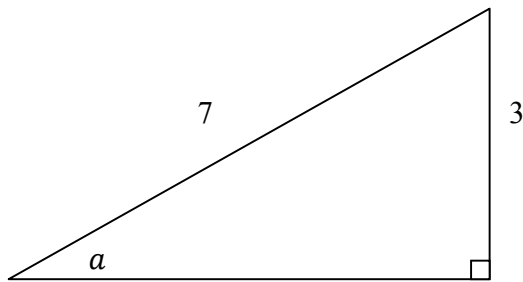
2) Which trigonometric ratio is equal to $\frac{3}{7}$?

- (A) $\sin a$ (B) $\tan a$ (C) $\cos a$ (D) $\sin^{-1} a$

3) Find x

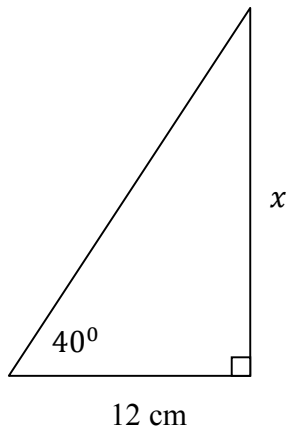

- (A) $12\sin 40^\circ$ (B) $12\tan 40^\circ$ (C) $12\cos 40^\circ$ (D) $\frac{\tan 40^\circ}{12}$

4) Find the length of y

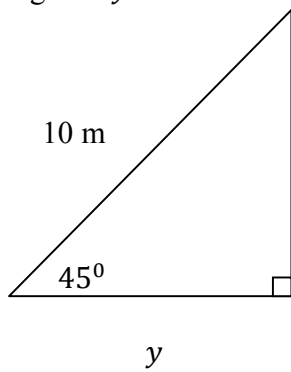

(A) $10\sin 45^\circ$

(B) $10\tan 45^\circ$

(C) $\frac{\tan 45^\circ}{10}$

(D) $10\cos 45^\circ$

5) What is the length of a ?

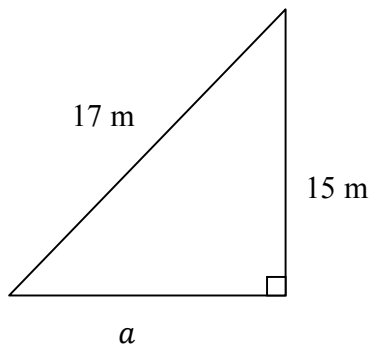

- (A) 8 cm (B) 12 cm (C) 10 cm (D) 16 cm

6) $\sin X =$

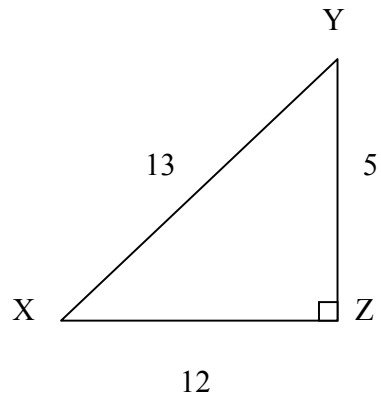

- (A) $\frac{5}{12}$ (B) $\frac{5}{13}$ (C) $\frac{12}{13}$ (D) $\frac{13}{12}$

7) A ladder rests against a building. How high up is the ladder?

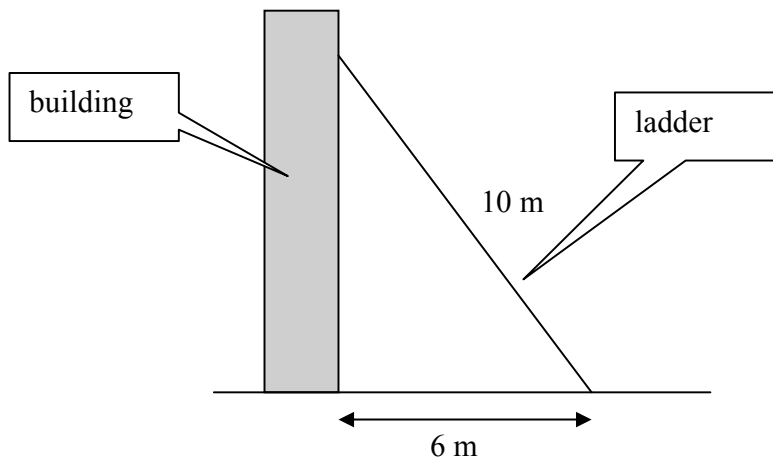

- (A) 4 m (B) 6 m (C) 10 m (D) 8 m

8) Which ratio is equal to $\frac{8}{10}$?

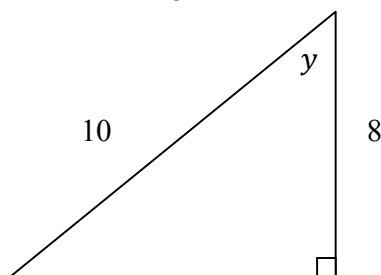

- (A) $\cos y$
 (B) $\sin y$
 (C) $\tan y$
 (D) $a^2 = b^2 + c^2 - bc \cos A$

9) Which ratio gives $\frac{7}{11}$?

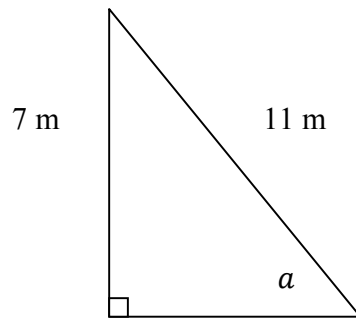

- (A) $\tan a$ (B) $\sin a$ (C) $\cos a$ (D) $a^2 = b^2 + c^2 - bc \cos A$

10) Find x

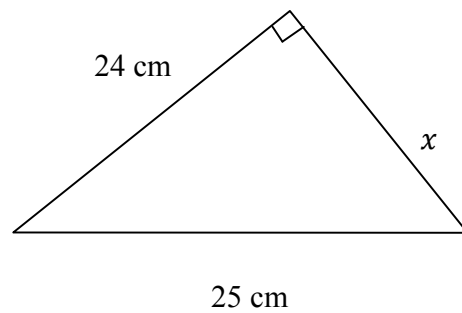

- (A) 4 cm
(B) 6 cm
(C) 7 cm
(D) 10 cm

11) A plank of wood rests against a concrete wall. The plank is 13 m long. The base of the plank is 5 m away from the base of the wall. How high is the wall?

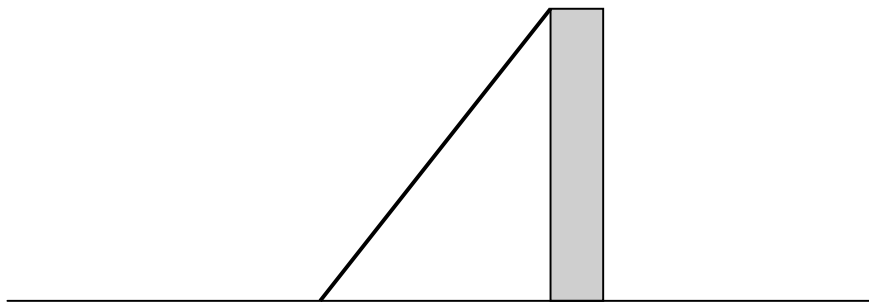

- (A) 8 m (B) 9 m (C) 10 m (D) 12 m

12) Find the length m

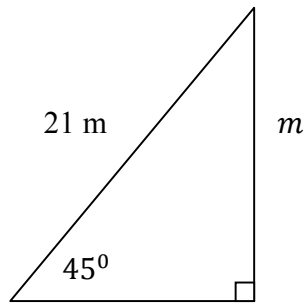

- (A) $21\tan 45^\circ$
 (B) $21\cos 45^\circ$
 (C) $\frac{\tan 45^\circ}{21}$
 (D) $21\sin 45^\circ$

13) Find h

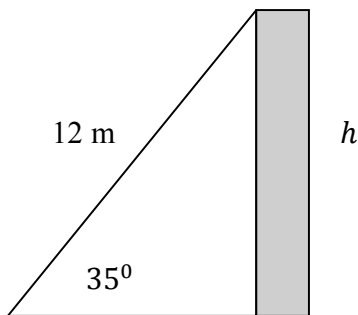

- (A) $12\sin 35^\circ$
 (B) $12\cos 35^\circ$
 (C) $\frac{\tan 35^\circ}{12}$
 (D) $12\tan 35^\circ$

14) What is $\tan \theta$?

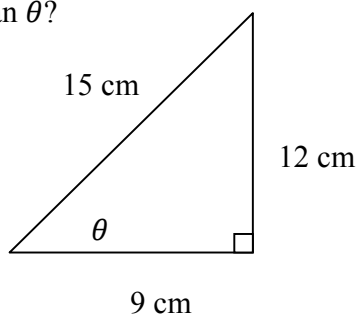

- (A) $\frac{12}{15}$ (B) $\frac{15}{12}$
 (C) $\frac{12}{9}$ (D) $\frac{9}{12}$

15) Calculate d

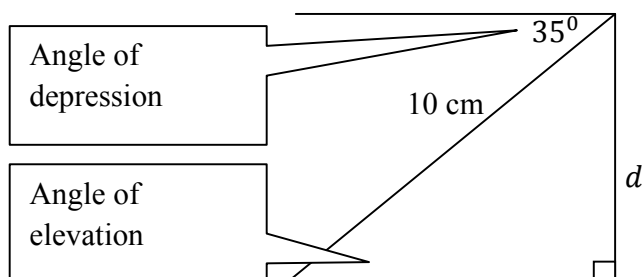

- (A) $10\tan 35^\circ$
 (B) $10\sin 35^\circ$
 (C) $10\cos 35^\circ$
 (D) $\frac{\tan 35^\circ}{10}$

16) Find z

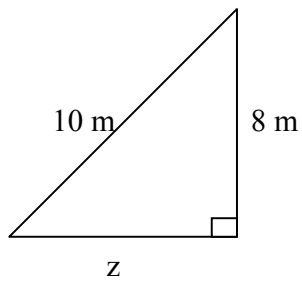

- (A) 12 cm
 (B) 9 cm
 (C) 11 cm
 (D) 6 cm

17) What is angle p ?

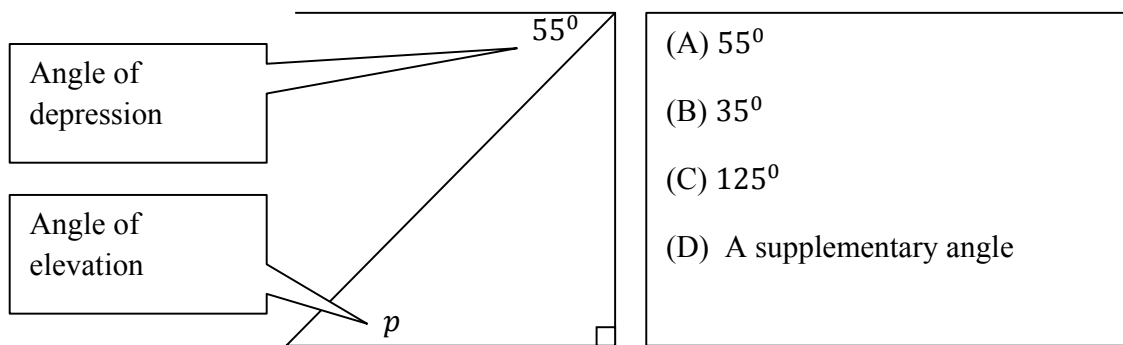

- (A) 55°
 (B) 35°
 (C) 125°
 (D) A supplementary angle

18)

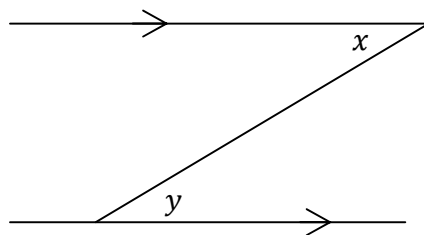

In the diagram above angles x and y are

- (A) Vertically opposite
 (B) Corresponding
 (C) Interior angles
 (D) Alternate

19) Which Theorem can be used in the triangle to find any unknown side?

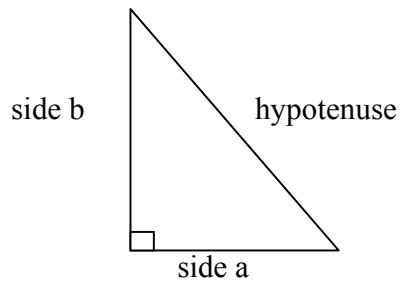

- (A) Cosine rule
- (B) Sine rule
- (C) Pthagoras' Theorem
- (D) Edgar Scantlebury's Theorem

20)

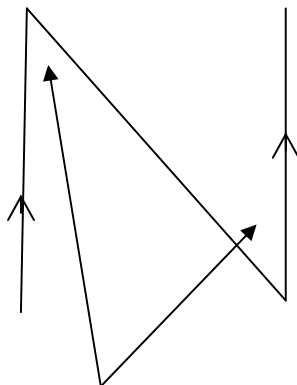

These two angles can be described as

- (A) Vertically opposite
- (B) Alternate
- (C) Interior
- (D) Corresponding

9 Vectors and matrices

TEST 1

1) A coast guard vessel sails 12 km due north. It then changes direction and moves 20 km due west. Which diagram represents this?

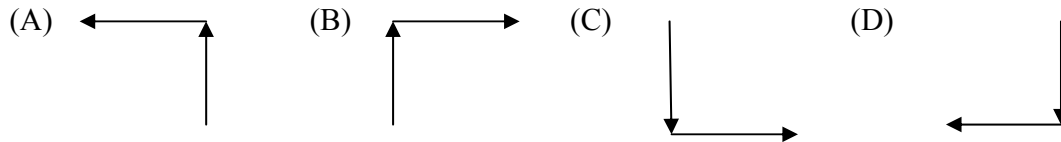

2) During the Afghanistan War, predator drones were widely used by the military. In a mission, a predator drone travelled south at a distance of 100 km. It then changed direction when the Military Base received new information. It travelled west for a distance of 225 km. Draw a diagram to represent this information.

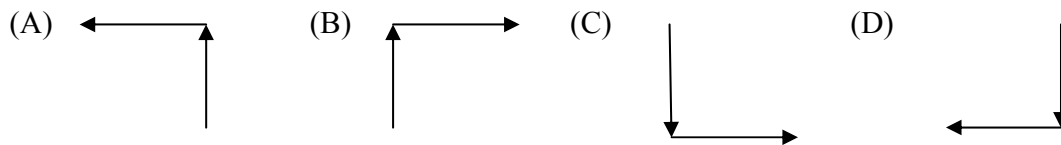

3) A taxi travels 7.4 km north from Chaguanas to Grand Bazaar Interchange. It then goes west to Port of Spain, which is 10.3 km from Grand Bazaar Interchange. Draw a diagram to represent this.

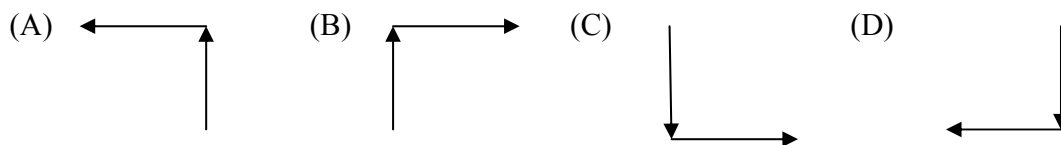

4) Raquel Cupido drives 7.4 km north from Chaguanas to Grand Bazaar Interchange. She then goes east to Arima which is 15.3 km from Grand Bazaar Interchange. Show this information on a diagram.

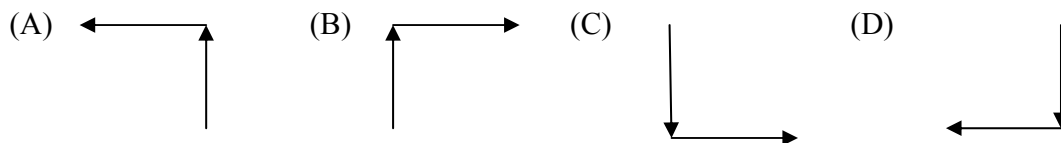

5) An aircraft is flying on a bearing of 060° . It then changes direction to 140° in a clockwise direction. What angle did it turned?

- (A) 200° (B) 180° (C) 80° (D) 100°

6) An experimental drome is going on a bearing of 080° . It then changes direction to 200° in a clockwise direction. What was the change in angle?

- (A) 200° (B) 180° (C) 280° (D) 120°

7) A jet fighter has travelled 200 km in a north east direction. It then changes direction and goes east for a distance of 125 km. Show this on a diagram.

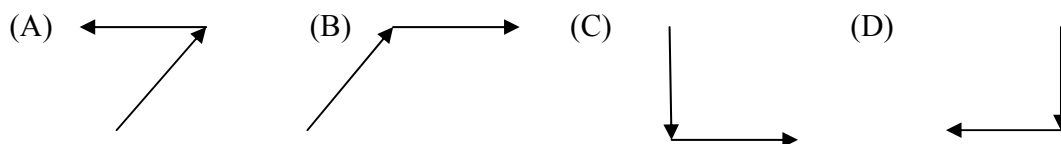

8) A light aircraft travels in a north west direction for 50 km. it then changes direction and moves east. Draw a diagram to show this.

9) Draw an arrow that points east?

10) Draw an arrow that points south east?

11) Write a vector equation to represent the information on the diagram.

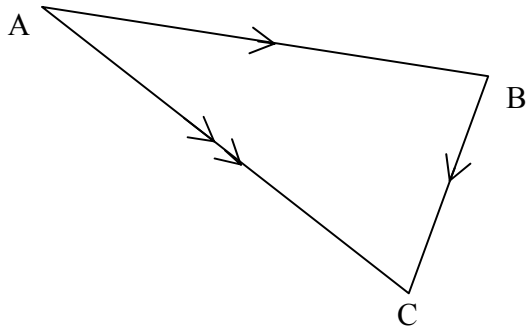

- (A) $\vec{AC} = \vec{AB} + \vec{BC}$ (B) $\vec{AC} = \vec{AB} - \vec{BC}$
 (C) $\vec{AC} + \vec{AB} + \vec{BC}$ (D) $\vec{CA} + \vec{AB} + \vec{BC}$

12) Which is correct for the vectors?

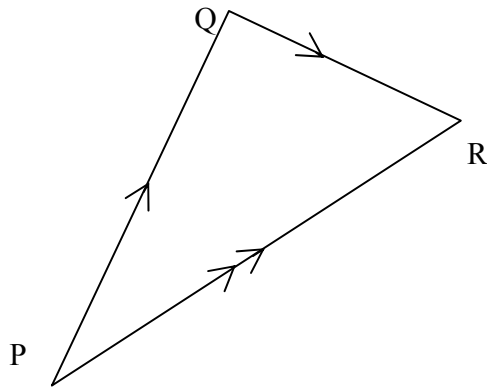

- (A) $\vec{PQ} + \vec{QR} + \vec{PR}$ (B) $\vec{PR} = \vec{PQ} - \vec{QR}$
 (C) $\vec{PR} + \vec{PQ} + \vec{QR}$ (D) $\vec{PR} = \vec{PQ} + \vec{QR}$

13) $\overrightarrow{XZ} =$

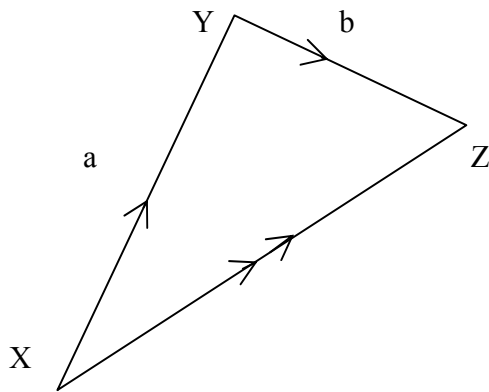

- | |
|------------------|
| (A) $a - b$ |
| (B) a and b |
| (C) $a + b$ |
| (D) a then b |

14) $\overrightarrow{MN} = 2a + 2b$. What is \overrightarrow{NM} ?

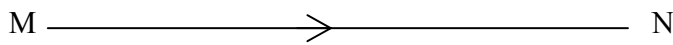

- (A) $-2a - 2b$ (B) $2a + 2b$ (C) $a + 2b$ (D) $a + b$

15) A vector $\overrightarrow{YZ} = 8b$. State what is vector \overrightarrow{ZY}

- (A) $8b$ (B) $-8b$ (C) $16b$ (D) $4b$

16) A vector $\overrightarrow{TS} = 4x - 8y$. What is $\frac{1}{2}\overrightarrow{TS}$?

- (A) $8x - 16y$ (B) $2x + 4y$ (C) $3x - 6y$ (D) $2x - 4y$

17) $\overrightarrow{PQ} = 6x - 9y$ and $\overrightarrow{YZ} = 4x - 6y$. Which statement is true?

- (A) \overrightarrow{YZ} is $\frac{2}{3}\overrightarrow{PQ}$ (B) \overrightarrow{YZ} and \overrightarrow{PQ} are next to each other
 (C) \overrightarrow{PQ} is twice \overrightarrow{YZ} (D) \overrightarrow{YZ} is a quarter of \overrightarrow{PQ}

18) $\vec{AZ} = 12m + 18n$ and $\vec{MN} = 2m + 3n$. What is a geometric property of both vectors?

- (A) They are at 90° to each other. (B) They are parallel
 (C) They intersect at M. (D) They act in opposite direction to each other.

19) $\vec{AZ} = 11p - 8q$ and $\vec{RT} = -8q + 11p$. What can you say about these vectors?

- (A) They are at 90° to each other. (B) They are parallel
 (C) They are equal. (D) They act in opposite direction to each other.

20) What is the magnitude of the position vector \vec{OB} ?

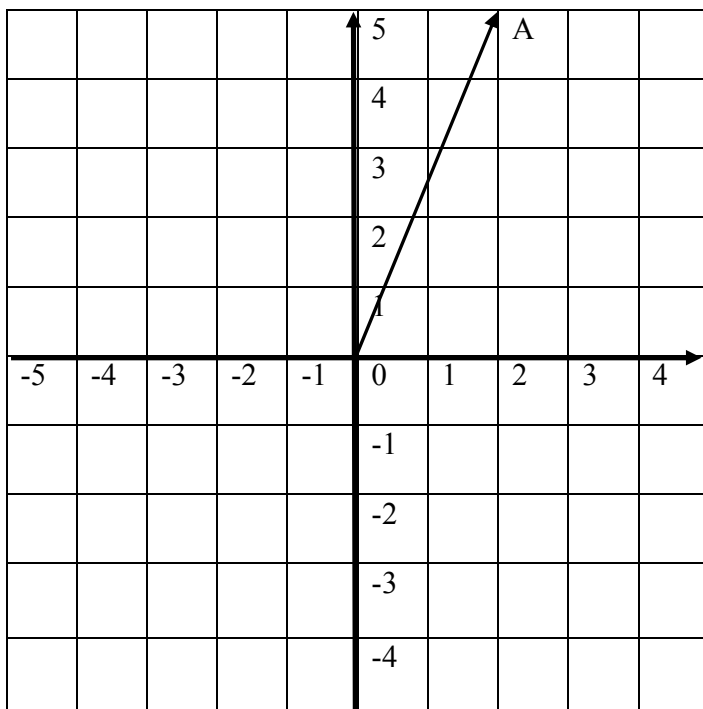

- (A) $\sqrt{29}$ (B) $\sqrt{25}$ (C) $\sqrt{49}$ (D) 5

ANSWERS

1 NUMBER THEORY AND COMPUTATION

TEST 1

- | | | | | | | |
|-------|-------|-------|-------|-------|-------|-------|
| 1) B | 2) A | 3) D | 4) C | 5) A | 6) A | 7) C |
| 8) D | 9) B | 10) D | 11) C | 12) A | 13) D | 14) D |
| 15) A | 16) C | 17) D | 18) B | 19) C | 20) D | |

TEST 2

- | | | | | | | |
|-------|-------|-------|-------|-------|-------|-------|
| 1) A | 2) C | 3) D | 4) B | 5) C | 6) C | 7) D |
| 8) B | 9) B | 10) A | 11) D | 12) C | 13) A | 14) D |
| 15) C | 16) A | 17) D | 18) B | 19) C | 20) A | |

TEST 3

- | | | | | | | |
|-------|-------|-------|-------|-------|-------|-------|
| 1) B | 2) C | 3) A | 4) B | 5) B | 6) A | 7) D |
| 8) A | 9) C | 10) D | 11) B | 12) C | 13) D | 14) A |
| 15) C | 16) D | 17) A | 18) B | 19) C | 20) D | |

TEST 4

- | | | | | | | |
|-------|-------|-------|-------|-------|-------|-------|
| 1) A | 2) B | 3) D | 4) C | 5) C | 6) A | 7) B |
| 8) D | 9) A | 10) C | 11) B | 12) D | 13) C | 14) A |
| 15) C | 16) D | 17) B | 18) B | 19) A | 20) C | |

TEST 5

- | | | | | | | |
|-------|-------|-------|-------|-------|-------|-------|
| 1) D | 2) A | 3) B | 4) C | 5) D | 6) A | 7) B |
| 8) C | 9) D | 10) B | 11) A | 12) C | 13) D | 14) A |
| 15) C | 16) B | 17) D | 18) A | 19) C | 20) B | |

2 CONSUMER ARITHMETIC

TEST 1

- | | | | | | | |
|-------|-------|-------|-------|-------|-------|-------|
| 1) D | 2) A | 3) C | 4) B | 5) D | 6) C | 7) A |
| 8) B | 9) D | 10) A | 11) C | 12) D | 13) A | 14) C |
| 15) D | 16) A | 17) C | 18) B | 19) D | 20) A | |

TEST 2

- | | | | | | | |
|-------|-------|-------|-------|-------|-------|-------|
| 1) A | 2) C | 3) B | 4) D | 5) C | 6) A | 7) B |
| 8) C | 9) D | 10) B | 11) A | 12) A | 13) C | 14) D |
| 15) B | 16) A | 17) D | 18) B | 19) C | 20) D | |

TEST 3

- | | | | | | | |
|-------|-------|-------|-------|-------|-------|-------|
| 1) A | 2) C | 3) B | 4) D | 5) D | 6) A | 7) C |
| 8) D | 9) A | 10) C | 11) B | 12) D | 13) A | 14) C |
| 15) B | 16) A | 17) D | 18) C | 19) D | 20) B | |

TEST 4

- | | | | | | | |
|-------|-------|-------|-------|-------|-------|-------|
| 1) C | 2) A | 3) D | 4) B | 5) C | 6) A | 7) D |
| 8) C | 9) A | 10) B | 11) D | 12) C | 13) A | 14) D |
| 15) A | 16) B | 17) D | 18) C | 19) A | 20) B | |

3 ALGEBRA

TEST 1

- | | | | | | | |
|-------|-------|-------|-------|-------|-------|-------|
| 1) A | 2) D | 3) B | 4) C | 5) D | 6) A | 7) B |
| 8) C | 9) D | 10) B | 11) A | 12) C | 13) D | 14) D |
| 15) A | 16) B | 17) C | 18) A | 19) D | 20) B | |

TEST 2

- | | | | | | | |
|-------|-------|-------|-------|-------|-------|-------|
| 1) C | 2) A | 3) D | 4) B | 5) D | 6) A | 7) C |
| 8) B | 9) D | 10) A | 11) C | 12) B | 13) D | 14) A |
| 15) C | 16) B | 17) D | 18) A | 19) C | 20) B | |

TEST 3

- | | | | | | | |
|-------|-------|-------|-------|-------|-------|-------|
| 1) A | 2) D | 3) B | 4) C | 5) D | 6) A | 7) A |
| 8) C | 9) B | 10) A | 11) C | 12) D | 13) B | 14) A |
| 15) D | 16) A | 17) B | 18) D | 19) C | 20) A | |

TEST 4

- | | | | | | | |
|-------|-------|-------|-------|-------|-------|-------|
| 1) B | 2) B | 3) A | 4) D | 5) C | 6) B | 7) A |
| 8) D | 9) C | 10) B | 11) A | 12) D | 13) B | 14) C |
| 15) A | 16) D | 17) B | 18) C | 19) A | 20) D | |

TEST 5

- | | | | | | | |
|------|------|-------|------|------|------|------|
| 1) B | 2) D | 3) C | 4) A | 5) D | 6) C | 7) D |
| 8) B | 9) A | 10) D | | | | |

11)

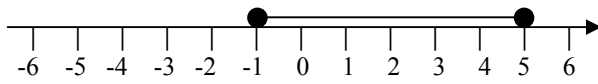

12)

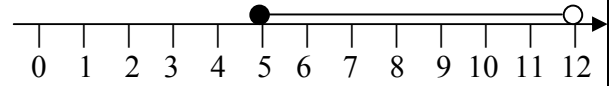

13)

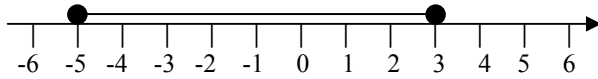

14)

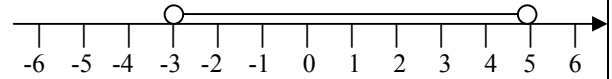

15)

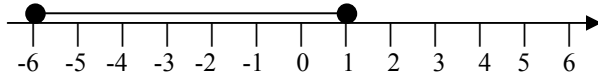

16)

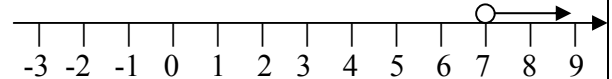

17)

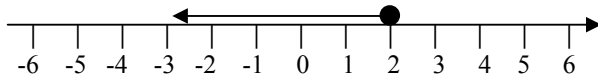

18)

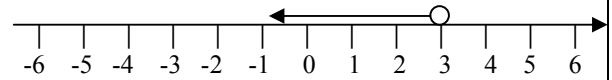

19)

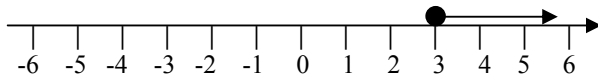

20)

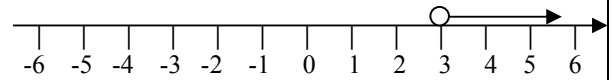

4 SETS

TEST 1

- 1) D 2) A 3) C 4) D 5) B 6) A 7) D
 8) D 9) C 10) A 11) D 12) C 13) B 14) A
 15) C

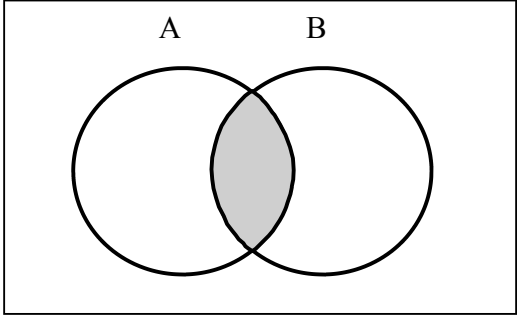
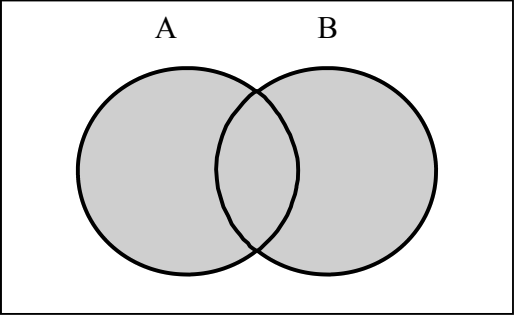
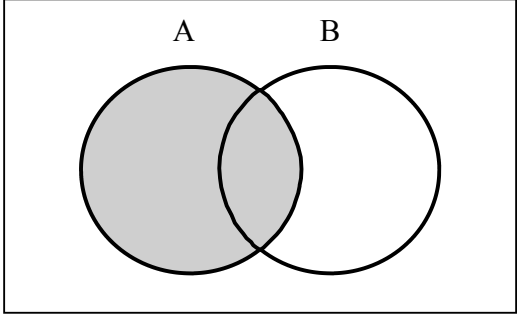
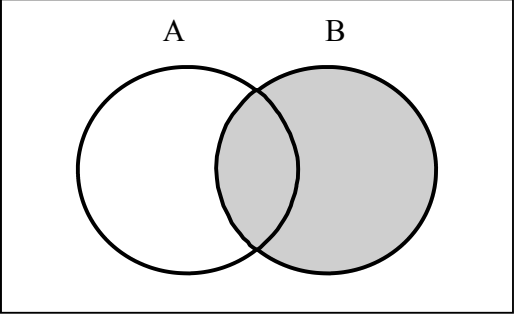
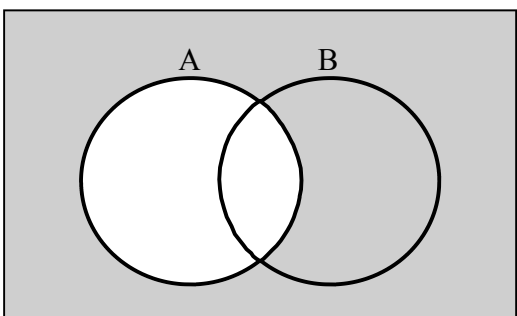
<p>16)</p> 	<p>17)</p> 
<p>18)</p> 	<p>19)</p> 
<p>20)</p> 	Empty Venn diagram box

TEST 2

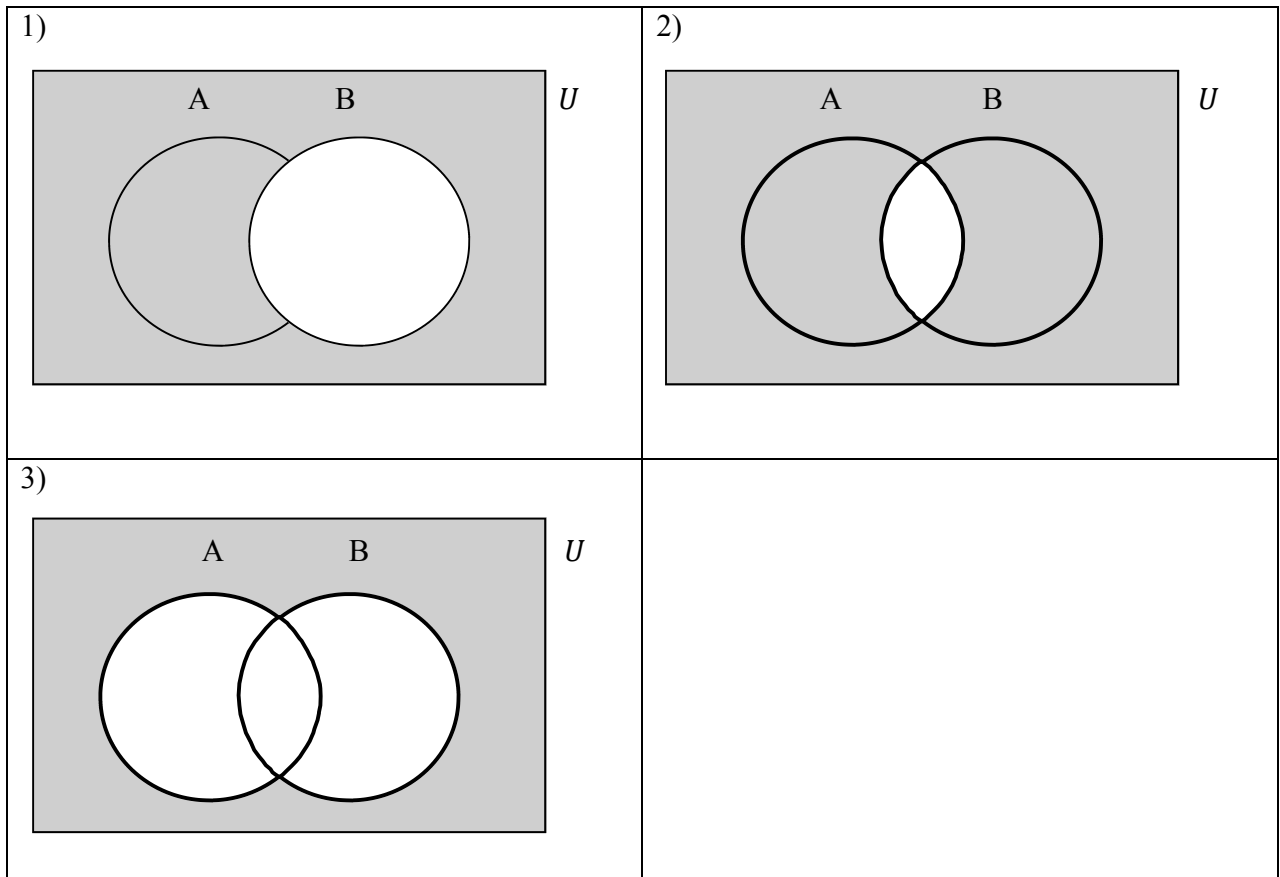

- | | | | | | | |
|-------|-------|-------|-------|-------|-------|-------|
| 4) D | 5) D | 6) A | 7) B | 8) D | 9) C | 10) A |
| 11) B | 12) D | 13) C | 14) A | 15) D | 16) A | 17) B |
| 18) C | 19) D | 20) A | | | | |

TEST 3

- | | | | | | | |
|-------|-------|-------|-------|-------|-------|-------|
| 1) A | 2) D | 3) C | 4) B | 5) D | 6) C | 7) A |
| 8) D | 9) C | 10) D | 11) A | 12) B | 13) D | 14) D |
| 15) A | 16) C | 17) D | 18) B | 19) A | 20) D | 21) C |

TEST 4

- | | | | | | | |
|------|------|-------|-------|-------|-------|-------|
| 1) C | 2) A | 3) A | 4) B | 5) C | 6) D | 7) B |
| 8) A | 9) C | 10) B | 11) D | 12) A | 13) C | 14) B |

15) C

16) D

17) A

19) A

20) C

18)

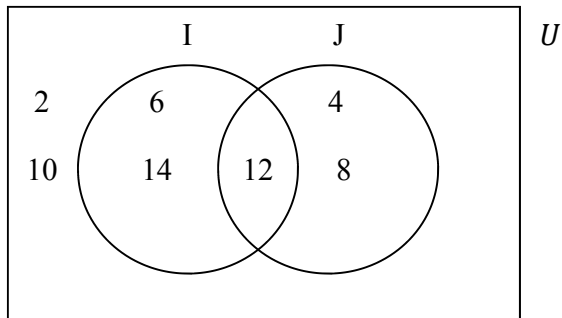

5 MEASUREMENT

TEST 1

1) D

2) A

3) C

4) B

5) D

6) A

7) C

8) C

9) A

10) D

11) B

12) A

13) C

14) D

15) A

16) D

17) C

18) B

19) A

20) D

TEST 2

1) B

2) A

3) D

4) B

5) B

6) C

7) A

8) D

9) C

10) A

11) B

12) D

13) C

14) A

15) D

16) B

17) C

18) A

19) D

20) C

TEST 3

1) D

2) A

3) C

4) D

5) B

6) A

7) D

8) A

9) C

10) B

11) A

12) D

13) B

14) B

15) C

16) A

17) B

18) D

19) C

20) A

21) D

TEST 4

1) A

2) D

3) C

4) B

5) C

6) A

7) D

8) B

9) A

10) C

11) C

12) A

13) A

14) C

15) D

16) B

17) A

18) C

19) B

20) D

6 STATISTICS

TEST 1

- | | | | | | | |
|-------|-------|-------|-------|-------|-------|-------|
| 1) A | 2) D | 3) B | 4) C | 5) A | 6) D | 7) B |
| 8) A | 9) D | 10) C | 11) B | 12) A | 13) C | 14) B |
| 15) A | 16) B | 17) C | 18) D | 19) A | 20) B | |

TEST 2

- | | | | | | | |
|-------|-------|-------|-------|-------|-------|-------|
| 1) D | 2) C | 3) A | 4) B | 5) D | 6) C | 7) A |
| 8) C | 9) A | 10) D | 11) B | 12) C | 13) A | 14) D |
| 15) C | 16) A | 17) B | 18) D | 19) C | 20) A | |

7 RELATIONS FUNCTIONS AND GRAPHS

TEST 1

- | | | | | | | |
|-------|-------|-------|-------|-------|-------|-------|
| 1) B | 2) A | 3) B | 4) D | 5) C | 6) A | 7) D |
| 8) C | 9) D | 10) B | 11) A | 12) C | 13) D | 14) B |
| 15) A | 16) C | 17) D | 18) B | 19) A | 20) D | |

TEST 2

- | | | | | | | |
|-------|-------|-------|-------|-------|-------|-------|
| 1) D | 2) A | 3) B | 4) D | 5) C | 6) A | 7) D |
| 8) C | 9) B | 10) A | 11) D | 12) C | 13) C | 14) B |
| 15) A | 16) D | 17) C | 18) A | 19) B | 20) C | |

TEST 3

- | | | | | | | |
|-------|-------|-------|-------|-------|-------|-------|
| 1) C | 2) A | 3) B | 4) D | 5) A | 6) C | 7) A |
| 8) D | 9) A | 10) A | 11) D | 12) C | 13) A | 14) B |
| 15) B | 16) C | 17) D | 18) A | 19) B | 20) C | |

TEST 4

- | | | | | | | |
|-------|-------|-------|-------|-------|-------|-------|
| 1) B | 2) A | 3) C | 4) D | 5) B | 6) A | 7) C |
| 8) D | 9) A | 10) C | 11) D | 12) B | 13) A | 14) C |
| 15) B | 16) D | 17) A | 18) C | 19) D | 20) B | |

TEST 5

- | | | | | | | |
|-------|-------|-------|-------|-------|-------|-------|
| 1) B | 2) A | 3) D | 4) C | 5) B | 6) D | 7) A |
| 8) C | 9) B | 10) D | 11) A | 12) B | 13) D | 14) A |
| 15) D | 16) D | 17) A | 18) C | 19) B | 20) C | |

TEST 6

- | | | | | | | |
|----------------------|----------|----------------------|----------|-----------------------|------|------|
| 1) C | 2) B | 3) D | 4) A | 5) C | 6) C | 7) A |
| 8) A | 9) D | 10) 4, 1, 0, 1, 4 | | 11) 5, 2, 1, 2, 5 | | |
| 12) 6, 3, 2, 3, 6 | | 13) -3, -1, 1, 3, 5 | | 14) -9, -5, -1, 3, 7 | | |
| 15) -7, -4, -1, 2, 5 | | 16) 0, 3, 8, 15, 24 | | 17) 4, 9, 16, 25, 36 | | |
| 18) 4, 8, 14, 22, 32 | | 19) 2, 9, 20, 35, 54 | | 20) 3, 11, 23, 39, 59 | | |
| 21) A, B, C | 22) E, F | 23) D | 24) G, H | 25) D | | |

8 GEOMETRY AND TRIGONOMETRY

TEST 1

1) Label hypotenuse, side a and side b.

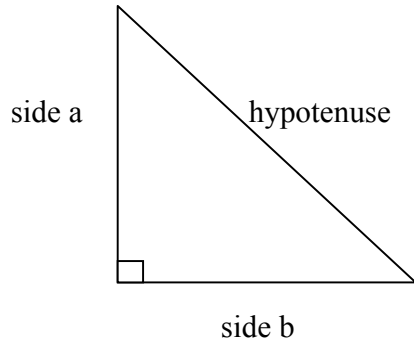

2) Label hypotenuse, side x and side y.

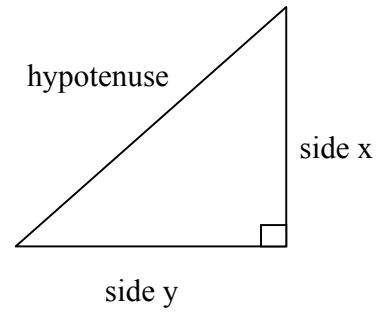

3) Label hypotenuse, a and b.

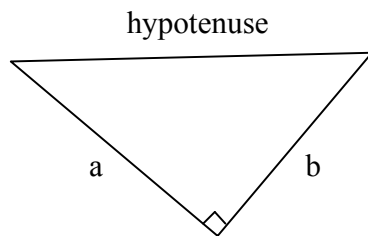

4) Label hypotenuse, 3 m and 4 m.

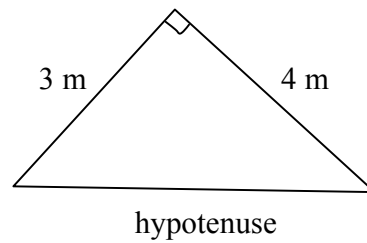

5) Label hypotenuse, 5 cm and 12 cm.

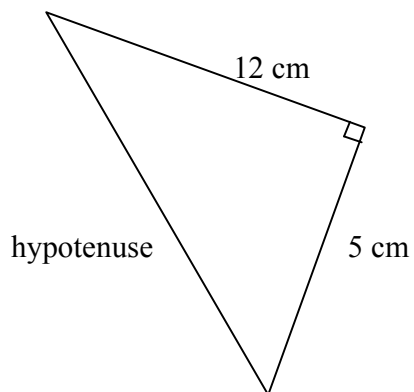

6) Label hypotenuse, 6 cm and 8 cm.

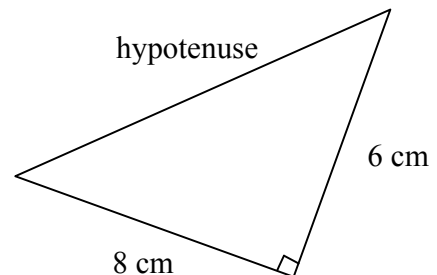

- 7) 5 8) 13 9) 10 10) 15 11) 41 12) 20
 13) 3 14) 5 15) 6 16) 9 17) 12 18) 15
 19) C 23) A 24) D

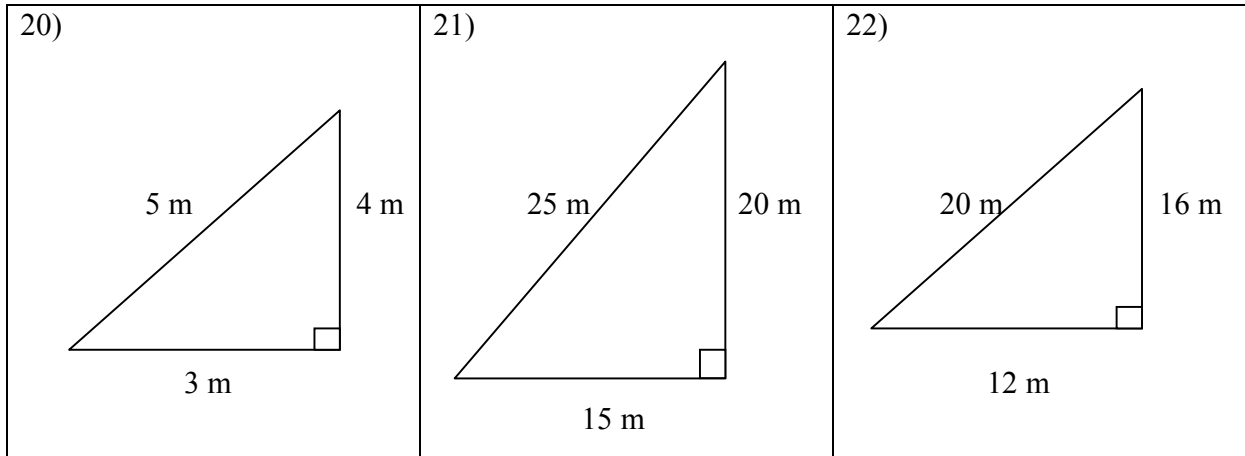

TEST 2

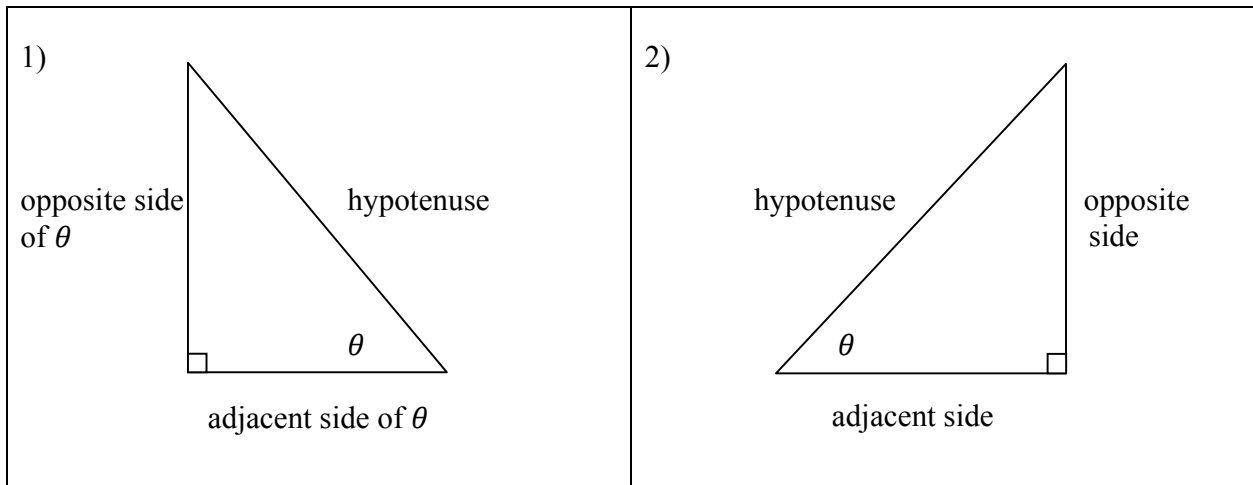

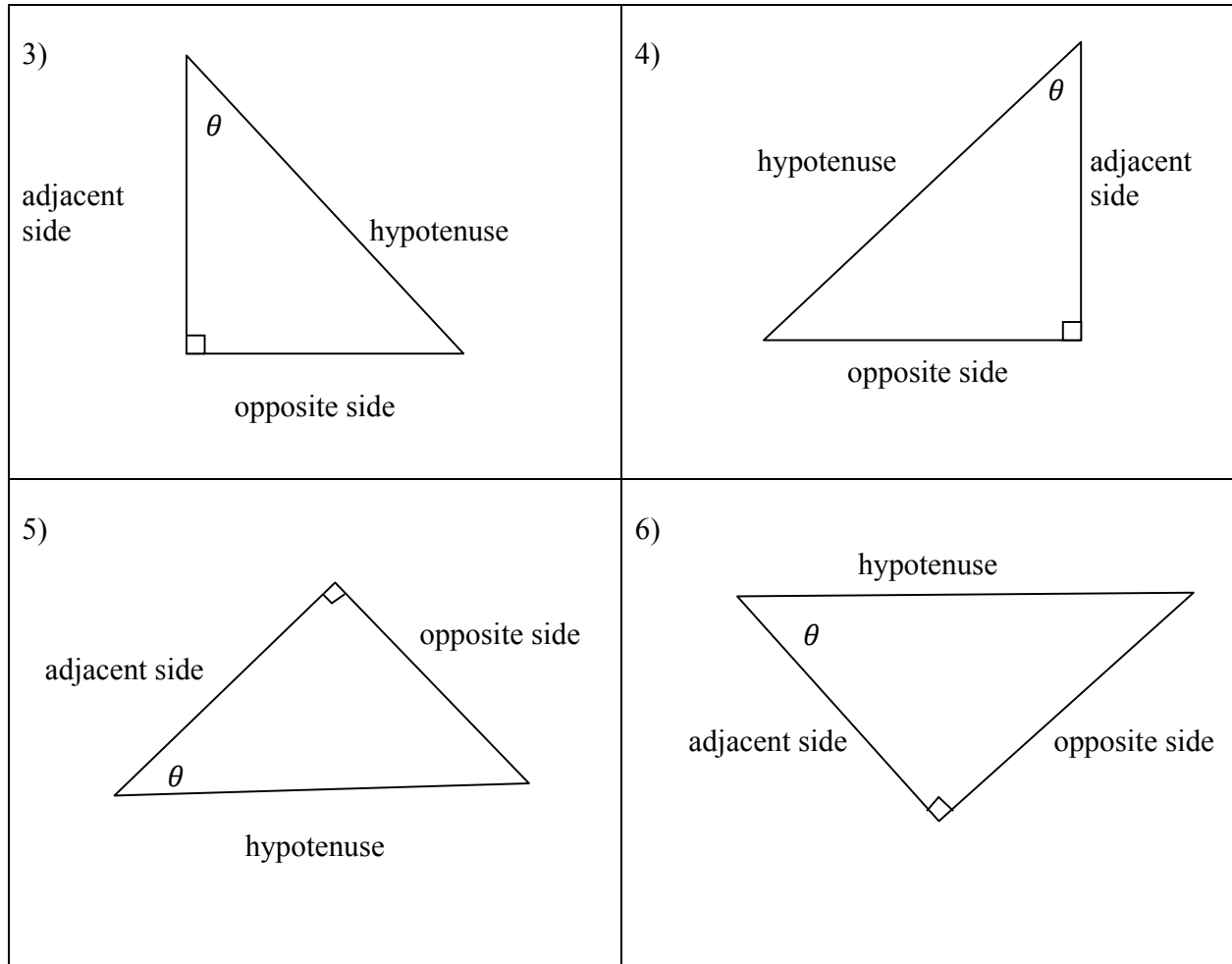

7) $\frac{4}{5}$

8) $\frac{12}{13}$

9) $\frac{9}{41}$

10) $\frac{8}{10}$

11) $\frac{9}{15}$

12) $\frac{20}{25}$

13) $\frac{4}{3}$

14) $\frac{12}{5}$

15) $\frac{9}{40}$

16) $\frac{8}{6}$

17) $\frac{9}{12}$

18) $\frac{20}{15}$

19) $\frac{3}{5}$

20) $\frac{5}{13}$

21) $\frac{40}{41}$

22) $\frac{6}{10}$

23) $\frac{12}{15}$

24) $\frac{15}{25}$

TEST 3

<p>1)</p>	<p>2)</p>
<p>3)</p>	<p>4)</p>
<p>5)</p>	<p>6)</p>

- 7) 33 8) 25 9) 41 10) 52 11) 58 12) 49
 13) $b + 1.8$ 14) $x + 1.8$ 15) $y + 1.8$ 16) $x + 1.8$ 17) $a + 1.8$ 18) $b + 1.8$
 19) $12\tan 58^\circ + 1.8$ 20) $100\tan 72.8^\circ + 1.8$ 21) $50\tan 63^\circ + 1.8$
 22) $200\tan 61^\circ + 1.8$

TEST 4

- 1) B 2) A 3) C 4) C 5) B 6) A 7) B
 8) D 9) C 10) B 11) B 12) A 13) C 14) D
 15) A 16) A 17) C 18) D 19) B 20) A

TEST 5

- 1) A 2) C 3) B 4) D 5) C 6) C 7) C
 8) B 9) A 10) D 11) C 12) B 13) A 14) D
 15) C 16) B 17) A 18) D 19) C 20) A

TEST 6

1) Reflect the line in the x-axis. Draw its image?

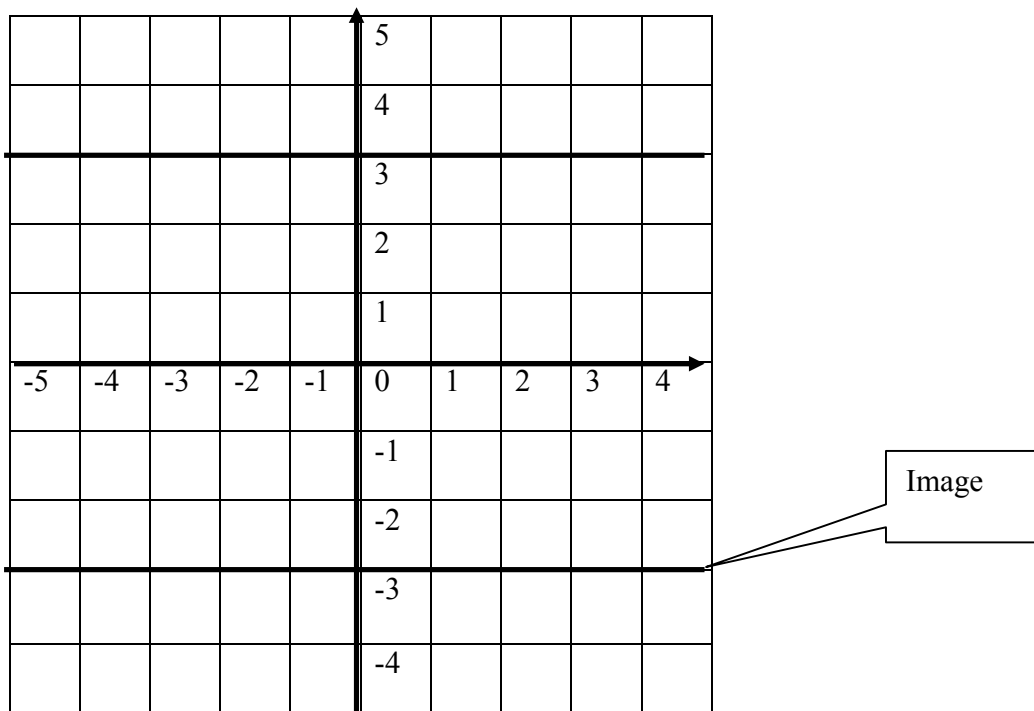

2) Reflect the line in the y-axis. Draw its image.

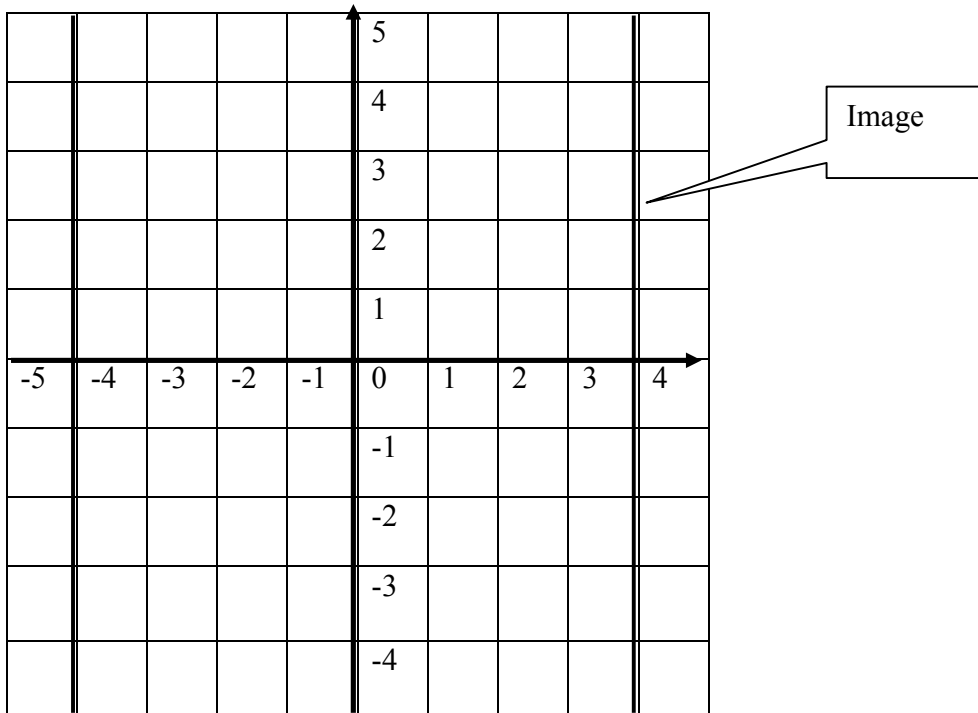

3) Draw the reflection of the triangle in the x-axis.

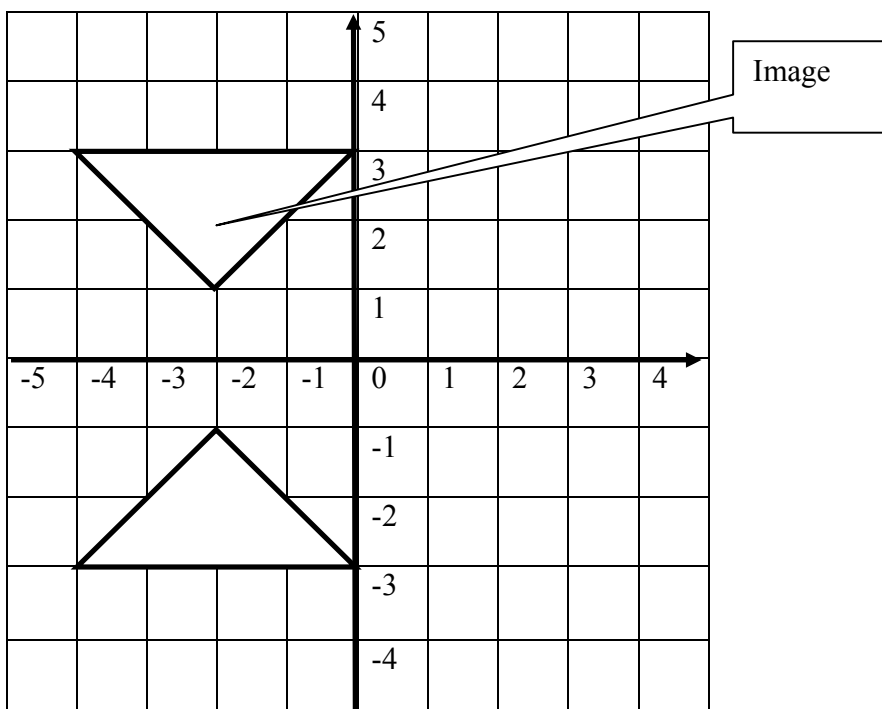

4) Draw the reflection of the square in the y-axis.

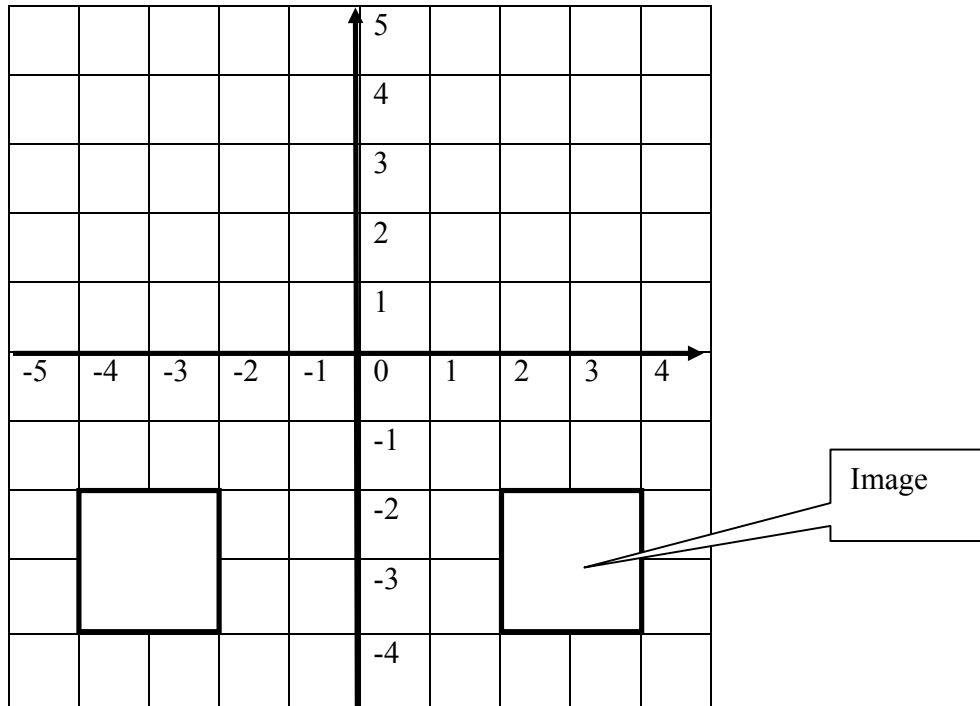

- 5) A 6) C 7) D 8) B 9) A 10) B 11) A
 12) C 13) D 14) B 15) A 16) D 17) C 18) B
 19) A 20) D

TEST 7

- 1) B 2) B 3) A 4) B 5) (0, 0) 6) (1, 0)
 7) (2, 2) 8) (3, 3) 9) A 10) A 11) B 12) A 13) D
 14) B 15) D 16) C

17) Draw the image of the line when it is rotated 90° in a clockwise direction.

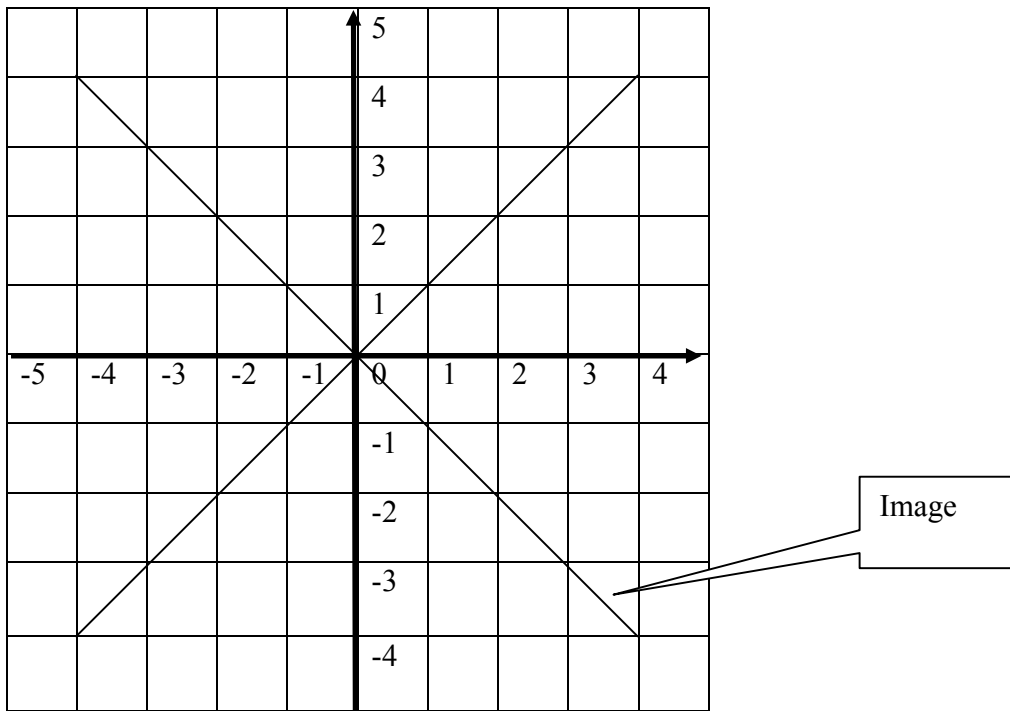

18) Draw the image of the line when it is rotated 90° in an anticlockwise direction.

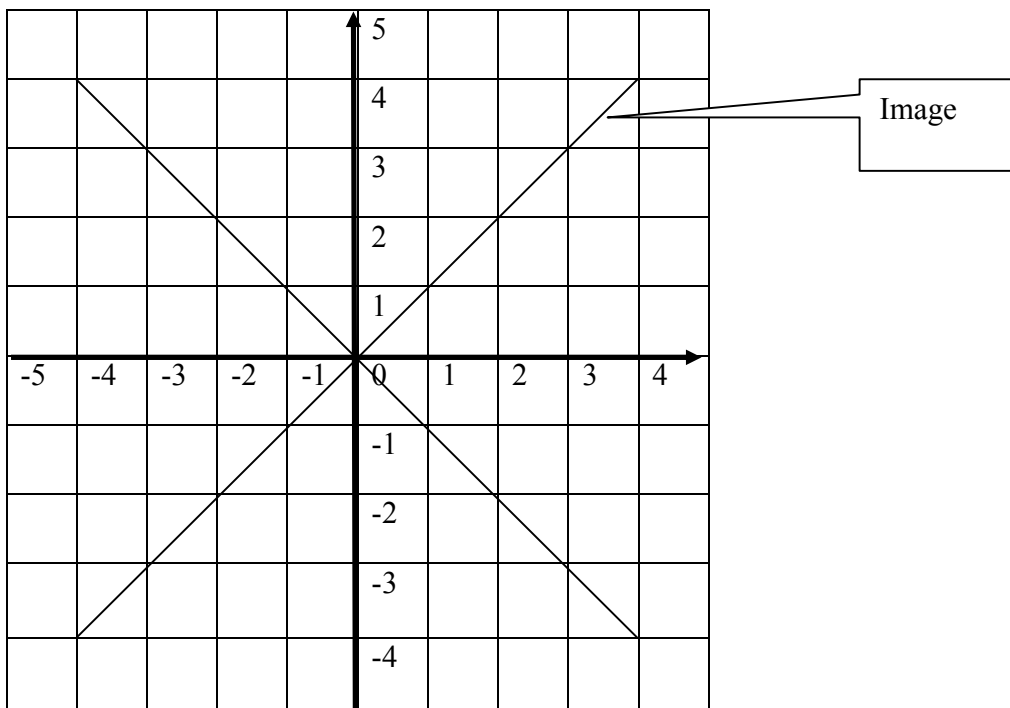

19) Draw the image of the line when it is rotated 45° in a clockwise direction.

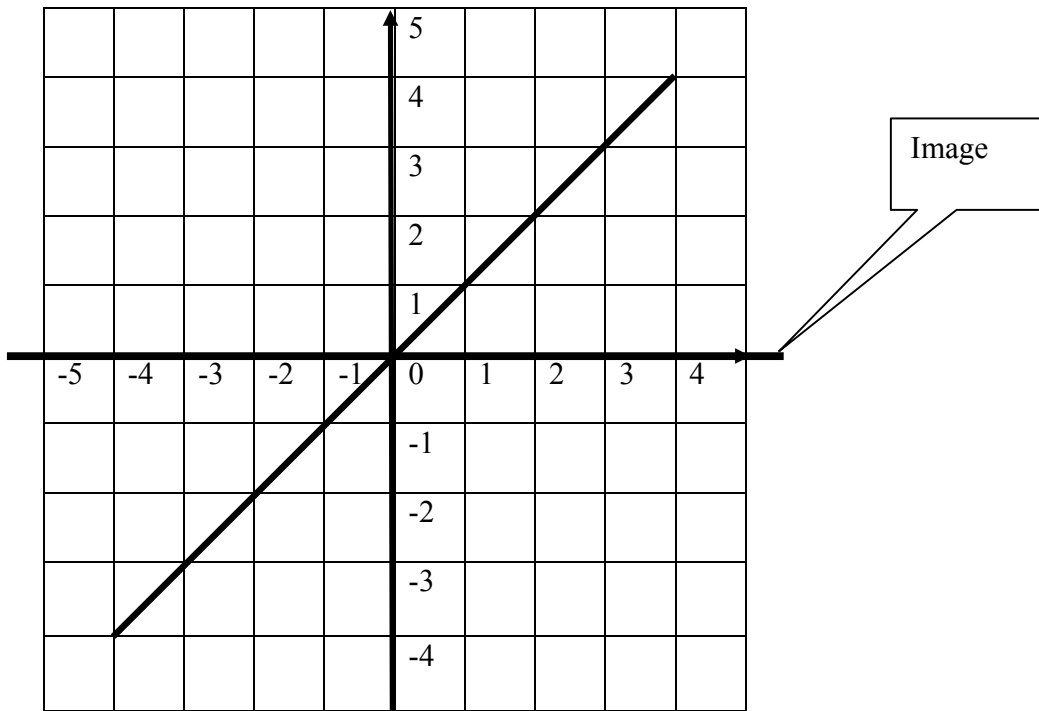

20) Draw the image of the line when it is rotated 45° in an anticlockwise direction.

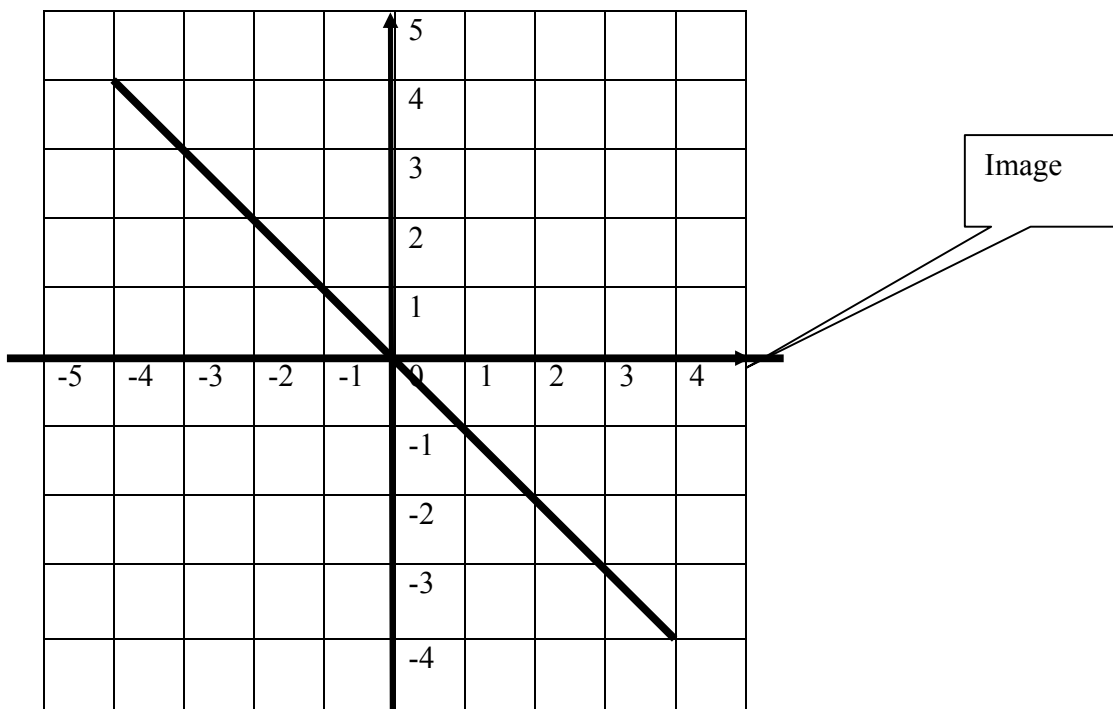

TEST 8



- | | | | | | |
|---------------|---------------|-----------------|-----------------|-------|-------|
| 1) Rotation | 2) Reflection | 3) Translation | 4) Enlargement | | |
| 5) Rotation | 6) Reflection | 7) Translation | 8) Enlargement | | |
| 9) Reflection | 10) Rotation | 11) Translation | 12) Enlargement | | |
| 13) A | 14) B | 15) D | 16) C | 17) A | 18) D |
| 19) B | 20) C | | | | |

TEST 9

- | | | | | | | |
|-------|-------|-------|-------|-------|-------|-------|
| 1) C | 2) A | 3) B | 4) D | 5) A | 6) B | 7) D |
| 8) A | 9) B | 10) C | 11) D | 12) D | 13) A | 14) C |
| 15) B | 16) D | 17) A | 18) D | 19) C | 20) B | |

9 VECTORS AND MATRICES

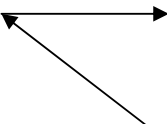
TEST 1

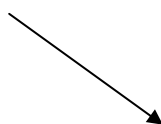
- | | | | | | | |
|-------|---|-------|---|-------|---|------|
| 1) A | 2) D | 3) A | 4) B | 5) C | 6) D | 7) B |
| 8) |  | 9) |  | 10) |  | |
| 11) A | 12) D | 13) C | 14) A | 15) B | 16) D | |
| 17) A | 18) B | 19) C | 20) A | | | |

ABOUT THE BOOK

This book covers multiple choice questions based on the topics outlined in the CSEC Mathematics syllabus. There are answers at the back of the last chapter to help those who use this book. Students are advised to check the answers after a test is completed. Attempts should be made to do over any wrong problems until the correct answers are found. There are some questions throughout the book that students are required to write answers for. This was purposely done to reinforce basic mathematical concepts and help students to build memory.

This book is designed for all form five students and all repeater students who are currently taking CSEC Mathematics examinations. Form four students who are keen on developing their multiple choice skills early, instead of waiting for the last term in form five, will benefit from this book. There are some Schools where form three students are introduced to form four topics. This book will help them to develop skills early.

A tutor is not needed if someone wants to use the book independently. Teachers who are giving crash courses can use the book with their students and they will be able to work through all the tests within a week. Anyone who uses this book will learn something and those who enjoy doing Mathematics will benefit tremendously.